

77220 LP12V7.0Ah(12V7Ah/C20)

Specifications

Rated Voltage	12V	
Nominal Capacity	7.0Ah	(C ₂₀ , 1.75V/cell)
Dimension	Length	151±2mm
	Width	65±1mm
	Container Height	93.5±1mm
	Total Height	99.5±1mm
Approx Weight	1.97 Kg	
Terminal	T1	
Container Material	ABS	
Rated Capacity (25°C)	7.00 Ah	(20hr, 0.350A, 1.75V/cell)
	6.53 Ah	(10hr, 0.653A, 1.75V/cell)
	5.85 Ah	(5hr, 1.19A, 1.75V/cell)
	5.30 Ah	(3hr, 1.77A, 1.75V/cell)
	4.27 Ah	(1hr, 4.27A, 1.60V/cell)
Max. Discharge Current	105A (5s)	
Internal Resistance (25°C)	Approx 33mΩ	
Operating Temp. Range	Discharge	-15 ~ 50°C
	Charge	-20 ~ 40°C
	Storage	-15 ~ 40°C
Nominal Operating Temp. Range	25±3°C	
Cycle Use	Initial Charging Current less than 2.1A. Voltage 14.4V~15.0V at 25°C Temp. Coefficient -30mV/°C	
Standby Use	Initial Charging Current less than 2.1A. Voltage 13.5V~13.8V at 25°C Temp. Coefficient -20mV/°C	
Effect of temp. to Capacity	40°C	103%
	25°C	100%
	0°C	86%
Self Discharge	LP series batteries may be stored for up to 6 months at 25°C and then a freshening charge is required. For higher temperatures the time interval will be shorter.	



Layout

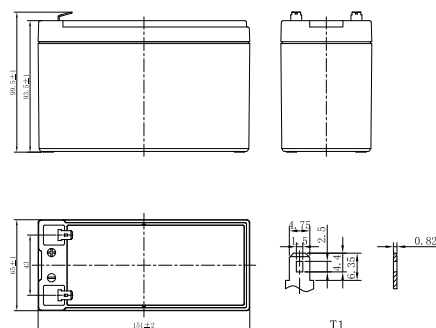

Constant Current Discharge (Amperes) at 25 °C

F.V/Time	5min	10min	15min	20min	30min	45min	1h	1.5h	2h	3h	4h	5h	6h	8h	10h	20h
1.85V/cell	17.0	12.5	9.90	8.10	6.12	4.64	3.91	2.90	2.38	1.72	1.36	1.16	0.99	0.780	0.637	0.343
1.80V/cell	18.5	13.2	10.3	8.35	6.28	4.73	3.99	2.95	2.41	1.74	1.38	1.18	1.01	0.790	0.644	0.347
1.75V/cell	19.9	13.8	10.7	8.60	6.43	4.83	4.06	3.00	2.45	1.77	1.40	1.19	1.02	0.800	0.653	0.350
1.70V/cell	21.4	14.4	11.1	8.86	6.57	4.92	4.13	3.05	2.49	1.79	1.42	1.21	1.03	0.809	0.660	0.354
1.67V/cell	22.3	14.8	11.3	9.01	6.67	4.98	4.17	3.08	2.51	1.81	1.43	1.22	1.04	0.816	0.665	0.356
1.60V/cell	24.3	15.7	11.8	9.40	6.87	5.11	4.27	3.14	2.56	1.84	1.46	1.24	1.06	0.829	0.675	0.361

Constant Power Discharge (Watts/cell) at 25 °C

F.V/Time	5min	10min	15min	20min	30min	45min	1h	1.5h	2h	3h	4h	5h	6h	8h	10h	20h
1.85V/cell	32.3	23.9	19.1	15.6	11.8	9.01	7.61	5.67	4.65	3.37	2.69	2.29	1.96	1.55	1.27	0.686
1.80V/cell	34.8	25.0	19.7	16.0	12.1	9.15	7.73	5.74	4.71	3.42	2.72	2.32	1.99	1.57	1.28	0.693
1.75V/cell	37.4	26.1	20.3	16.4	12.3	9.30	7.84	5.82	4.77	3.46	2.76	2.35	2.01	1.58	1.29	0.700
1.70V/cell	39.9	27.2	20.9	16.8	12.5	9.40	7.95	5.90	4.84	3.50	2.79	2.37	2.03	1.60	1.31	0.707
1.67V/cell	41.4	27.8	21.3	17.1	12.7	9.50	8.02	5.95	4.87	3.53	2.81	2.39	2.05	1.61	1.32	0.712
1.60V/cell	44.7	29.2	22.1	17.6	13.0	9.70	8.17	6.05	4.95	3.59	2.85	2.43	2.08	1.64	1.34	0.722

77220 LP12V7.0Ah(12V7Ah/C20)

Applications

- All purpose
- Uninterruptable Power Supply (UPS)
- Electric Power System (EPS)
- Emergency backup power supply
- Alarm and security system
- Communication power supply
- DC power supply
- Auto control system

General Features

- 5 years design life(25°C)
- Special exhaust structure and sealing technology, safe and reliable, flexible installation, convenient maintenance
- PbCaSn alloy for plate grids: less gassing, less self-discharging
- High quality AGM separator: extend cycle life and prevent micro short circuit
- High purity raw material: ensure low self discharge rate

Standards

- Compliance with IEC 60896 standards, EU Battery Directive
- UL, CE Certified
- IATF16949, ISO45001,ISO 9001 and ISO 14001 certified production facilities

Discharge Characteristics

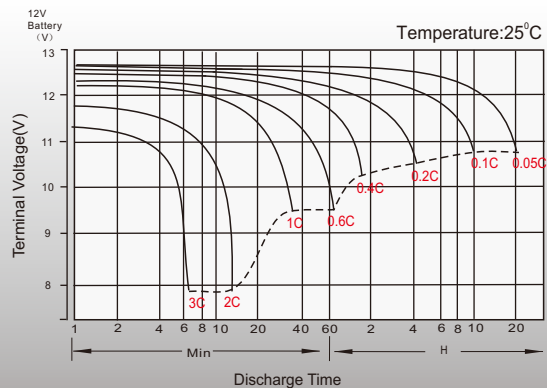

Float Charging Characteristics

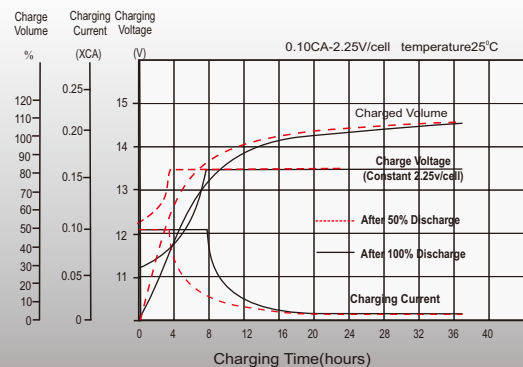

Temperature Effects in Relation to Battery Capacity

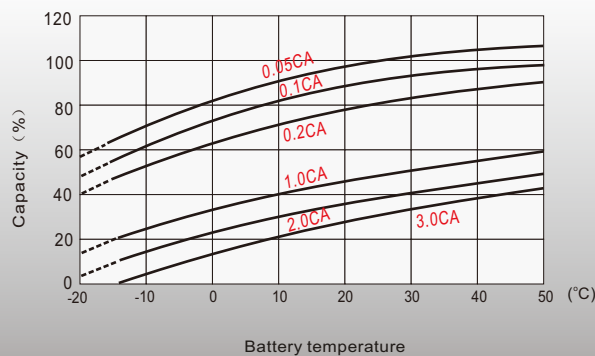

Effect of Temperature on Long Term Float Life

