

Redesign / Phase-Out

Launch of new control cards Delcon-2 for lift control valves

Our existing Delcon control cards for lift control valves have been completely revised. The new generation is called Delcon-2 and will be rolled out gradually starting in August 2025. As part of this changeover, the previous Delcon control cards will be removed from the product range.

Customers should note

What remains unchanged:

- The ground plane area of the Delcon-2 electronics is identical to that of the NTA-2 – fits directly into the existing elevator control system when replaced
- Compatibility with handheld terminal and computer interface
- Menu navigation and parameterization identical to previous Delcon

New or enhanced features:

- Uses the same basic hardware as iCon-2 (with up-to-date electronic components)
- Data logger function via USB interface
- Power supply with 24 VDC (optional: ground plane with power supply; available with input range 85 ... 305 VAC if no 24 VDC is available or power is insufficient)
- Standard integrated option for electric emergency lowering with 24 VDC battery

Comparison of hardware

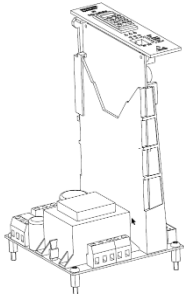
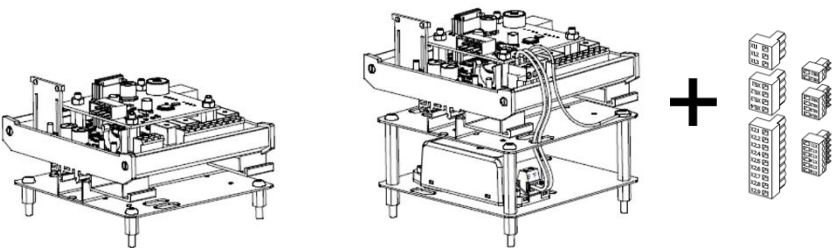
Delcon	Delcon-2
	
<p>Delta Controller with NTA-2 / VF-NTA-2</p>	<p>Support frame with or without power supply incl. plug set</p>

Further information

Details on the electrical connection diagram and rewiring from NTA-2 to Delcon-2 can be found in our technical documentation. Please refer to chapter 1.8.1.

Lift control valve LRV-1



Lift control valve VF-LRV



Lift control valve LRV-1 PM



Communication

This Technical info, like all previous Technical INFOs, can be found on our website in the section *LOGintern* → *General* → *Technical INFO*:

<https://www.bucherhydraulics.com/en/logintern>

Contact

For technical questions or additional information, please contact your designated sales representative.

You can find other contacts at www.bucherhydraulics.com