



Installation and operation manual for LDO AC 4.0 + 4.5 door drive

Please read the contents of this manual before assembly, installation and commissioning, retain the manual and provide it for future users, if necessary.
This ensures your safety and avoids damage to the door drive.

ETG Elevator Trading GmbH
Kömmplitzer Str.5
D-04519 Rackwitz
Bundesrepublik Deutschland
Telefon:+49 (0)34294 / 1797-00
Telefax: +49 (0)34294 / 1797-33
www.elevator-trading.de

Safety instructions

Foreword

	Page
1. Designed use	6
1.1 Intended use	6
1.2 Prohibited use	6
1.3 Obligations of the installation company	6
1.4 Expansions and accessories	6
2. Technical description	7
2.1 System description	7
2.2 Functionalities	7
2.3 Control elements and layout of inputs/outputs	9
3. Technical data	10
4. Assembly and installation	11
4.1. Mechanical assembly	
4.2. Power supply	
4.3. Switching the power supply on	
4.4. Configuration and door width estimation	
4.4.1. Door width estimation description	
4.4.2. Setting up configuration and door width estimation without a dongle	
4.5. Sending lift control messages and status output signals to the lift control system	
4.6. Positioning after a power outage or a power supply disconnection	
5. Configuration	14
6. Encoder	15
7. Error messages	15
8. WLAN Dongle	17
8.1 Configuration using WLAN Dongle	17
8.2 Error messages during work using WLAN Dongle	19

Safety instructions

Scope of application and instructions

This operation manual should be read and used by all individuals participating in assembly, commissioning and operation of the LDO AC 4.0 and LDO AC 4.5 door drives. Contents of this manual should be strictly observed.

Additional regulations

The following regulations should be observed in addition to this operation manual:

- Accident prevention regulations
 - VBG 1 General regulations,
 - VBG 4 Electric installations and accessories,
 - ZH 1/228 Safety regulations related to use of electric tools with increased electric hazard.
- Acts, regulations, safety regulations issued by national and international safety authorities, such as:
 - DIN VDE 0100 Construction of high current installation with rated voltage up to 1000 V
 - DIN VDE 0105 Operation of high current installations
 - DIN VDE 0106 Protection against hazardous bodily currents
 - Directive on use of electric equipment (EC Directive - 89/655/EEC)
 - Specialised professional regulations, provided that they do not render safety instructions provided in this manual ineffective.

Personnel use and availability

All operations described in this user manual should be performed under guidance and supervision of a trained specialist. A specialist is understood as an individual able to perform and to supervise performance of all work performed on the door drive in a professional manner.

The specialist should also:

- be at least 18 years old and have undergone the G 20 medical examination,
- be authorised by the installation company to perform work on the entire lift installation,
- fully read and understand the operation manual,
- be trained in the field of door drive technology and know its operation within the entire lift installation, including all related functionalities,
- have thorough knowledge of the entire lift installation, and of cooperation between individual assemblies and units,
- be able to prove adequate knowledge of occupational safety and accident prevention regulations, as well as of relevant technical rules.

The specialists should only perform and supervise operations described in this user manual



All further operations and work performed on the LDO AC 4.0 or LDO AC 4.5 door drives should be performed by Elevator Trading GmbH personnel only.

Accident prevention

Knowledge and observation of accident prevention regulations helps preventing accidents! Preventive measures aimed at identified accident sources and hazards can enable severe damage to be avoided.

Each employee is obliged to make all reasonable efforts aimed at accident and professional disease prevention. Identified hazard sources should be thoroughly remedied and eliminated. If this is impossible, hazardous locations should be secured and the identified hazard should be thoroughly reported to the supervisors and line managers.

Occupational protection measures

The operators shall have the following obligations ensuring safety at work:

- use PPE and observe all relevant regulations related to occupational safety, and prevent accidents and eliminate hazard sources,
- inspect and control operation and functionality of protective measures, installations etc., as well as to inspect technical condition of the installation in regular intervals,
- hazardous elements should be immediately withdrawn from operation and adequate protective measures should be implemented,
- faults found in assemblies, installations and parts of the installation as well as violations of the PPE use obligation should be immediately reported to the appropriate line manager,
- during work with live parts, such elements should be disconnected from power supply before the beginning of work.

Procedure related to accidents at work

If an accident occurs at work and its consequences are minor, first aid should be provided to the victim, promptly seek medical aid. Each such accident should be immediately reported to the company management. An accident report should be prepared.

Visitors and third parties

Presence of visitors and unauthorised individuals within the assembly area of the lift installation is prohibited.

Safety and warning signs

The following signs according to VBG 125 are used on parts and elements of the door drive and in this manual.



Warning against hazardous voltage



Disconnect power supply before starting work



Warning against automated operation

Foreword

This operation manual describes the door drives LDO AC 4.0 and LDO AC 4.5 for personal and goods lifts according to EN81.

This operation manual is divided into chapters. Chapter 1 defines the intended use of the door drive as a description of operation of the drive. In Chapter 2, technical description of the door drive is described, providing a good overview of design and operation of the equipment. It also provides explanations of control elements and indicators. The most important technical data is presented in Chapter 3. Chapter 4 describes operations required during assembly and installation. Configuration of the door drive is described in Chapter 5.



For clarity reasons, this operation manual does not include all detailed information related to all possible versions and variants of the LDO AC 4.0 / LDO AC 4.5 door drives and for the same reasons, it cannot include all possible configurations, modes of operation or maintenance operations. Should you wish to obtain further, specific information or if particular problems occur, the required information can be obtained by contacting Elevator Trading GmbH.



Elevator Trading GmbH indicates that contents of this operation manual are not a part of a prior or existing agreement, representation or a legal relationship, nor should they change any such legal instrument. The liability of Elevator Trading GmbH is specified by each individual sales and purchase contract, which also includes complete and specifically applicable warranty regulations. This contractual warranty conditions are neither expanded nor limited by explanations provided in this operation manual.



Elevator Trading GmbH continuously works on improvements of its equipment and its performance. Please be aware that figures and technical data related to the design, equipment and know-how can be subjected to technical changes resulting from general, technological advances.

Particular emphasis was placed on user-friendly design of the operation manual, using figures and text-based information. Instructions related to figures are indicated with brackets in the text. The first digit before the hyphen indicates the Chapter, and the figure number, whilst the digit after the hyphen indicates the reference number in the appropriate figure.

Example:
(Figure 3-2) indicates Figure 2 in Chapter 3

Important information for operators and maintenance personnel is indicated using appropriate pictograms.



Indicates important information which should be observed by the operators and by maintenance personnel.



Indicates work and operation methods and procedures which should be strictly observed in order to avoid damage or destruction of the door drive and of the entire lift installation.



Indicates work and operation methods and procedures which should be strictly observed in order to eliminate hazard to involved personnel.

1. Designed use

1.1 Intended use

The LDO AC 4.0 and LDO AC 4.5 door drives manufactured by Elevator Trading GmbH and described in this manual provides control over drives of electric lifts as understood according to EN 81.

This operation manual provides a precise description indicating how the door drive should be installed and operated, and which regulations and conditions should be observed.



All uses of the door drive described in the EN 81 document shall be understood as intended use of the equipment. All other uses shall be considered unintended and are prohibited.

1.2 Prohibited use

Each use of the door drive other than described in this operation manual and in the EN 81 document shall be considered prohibited. This applies, in particular, to limiting and rated parameters described in Chapter 3 "Technical Data" being exceeded or not observed.

Elevator Trading GmbH shall not be held responsible for any damage resulting from violation of prohibitions provided in this user manual.

1.3 Obligations of the installation company

The installation company which assembles and installs the entire and operational lift installation for the end user, and which provides commissioning and maintenance of the lift system, shall be responsible for intended use of the door drive, as described in this operation manual and in the EN 81 document. The installation company shall be obliged to include the operation manual for the LDO AC 4.0 and LDO AC 4.5 door drives in the operation manual or rules for the entire lift system, without changing any paragraphs of this manual or rendering them ineffective.

1.4 Expansions and accessories

If operational or ambient conditions of the door drive change such that the functioning or the specified limiting and rated values according to this manual may no longer be maintained, only Elevator Trading GmbH should undertake any appropriate modifications and adaptations of the equipment. Such modifications may also require a permit from local authorities.

Unauthorised modifications or expansions of the door drive may adversely influence safety of the equipment, and render the manufacturer warranty void.

2. Technical description

2.1 System description

The LDO AC 4.0 and LDO AC 4.5 door drives are „smart“ door drives. They allow opening and closing of lift doors with adjustable speeds and accelerations. The maintenance-free door drive includes a control system installed inside a housing, and the drive itself in a form of permanently excited, synchronous motor. The power transmission is provided using a toothed belt. The drive may operate both laterally and centrally opening doors. The door drive does not require a limit switch. The door width and the "open" and "closed" positions are recognized automatically. The master lift control system can be informed about the door status using relay contacts.

2.2 Functionalities

Door with recognition

Door width recognition must be activated as a part of assembly and installation as an automatic process. These operations are described in Chapter 4 "Assembly and installation."

"Door opening" command

The "door opening command" causes the door to open according to the programmed travel curve, as long as the command is active. The "door opening" command must be active during the entire opening motion of the door.

"Door closing" command

The "door closing command" causes the door to close according to the programmed travel curve, as long as the command is active. The "door closing" command must be active during the entire closing motion of the door.



The first closing motion after a power outage is performed slowly. Only steady door commands enable the door motor to be kept with its generated moment at the end positions. If no holding moment is presented in the "door closed" position (no door closing command is present), the door is closed automatically if it was open for more than 3 increments.

Interrupting and reversing the closing motion

There are three events which cause the closing motion of the door to be interrupted and reversed:

- The light barrier installed directly at the door drive signals a barrier crossing or interruption.
- The door encounters an obstacle during the closing motion.
- The door has already been blocked in the „open“ position.

If any of these three events is identified, the currently performed closing motion is briefly interrupted. As long as the obstacle causes the light barrier to be interrupted, the door is moving slowly towards its fully open position. Once the interruption is removed, the still present closing command is executed and the door is normally closed again.

The „push“ command

The „push“ command can be executed together with the „closing“ command using the control system. In this condition, the light barrier installed directly on the door drive is not observed, only mechanical reversing shall be recognized. The closing speed is lower in this case.

Emergency opening

Emergency opening with door closed is possible only under the following conditions:

- if the door does not move,
- a „door closing“ command is active in the lift control system and the door control system has been switched to holding moment, and
- no service button of the door drive has been operated.

If despite the "door closing" command the door is deliberately open by more than ca. 15 mm from the "door closed" position, the door identifies this condition as emergency opening and automatically removes the "door closing" command.



The force required in order to open the door is smaller than 300 N.

Light barrier

A voltage of 10 to 30V DC at the light barrier input is interpreted as beam interruption of a closed light barrier. This voltage is measured against 0V GND. Interruption of the light barrier when the door is closing causes the closing motion to be interrupted, and the door is then opened slowly if a LS command is active.

2.3 Control elements and connection layout on the circuit board

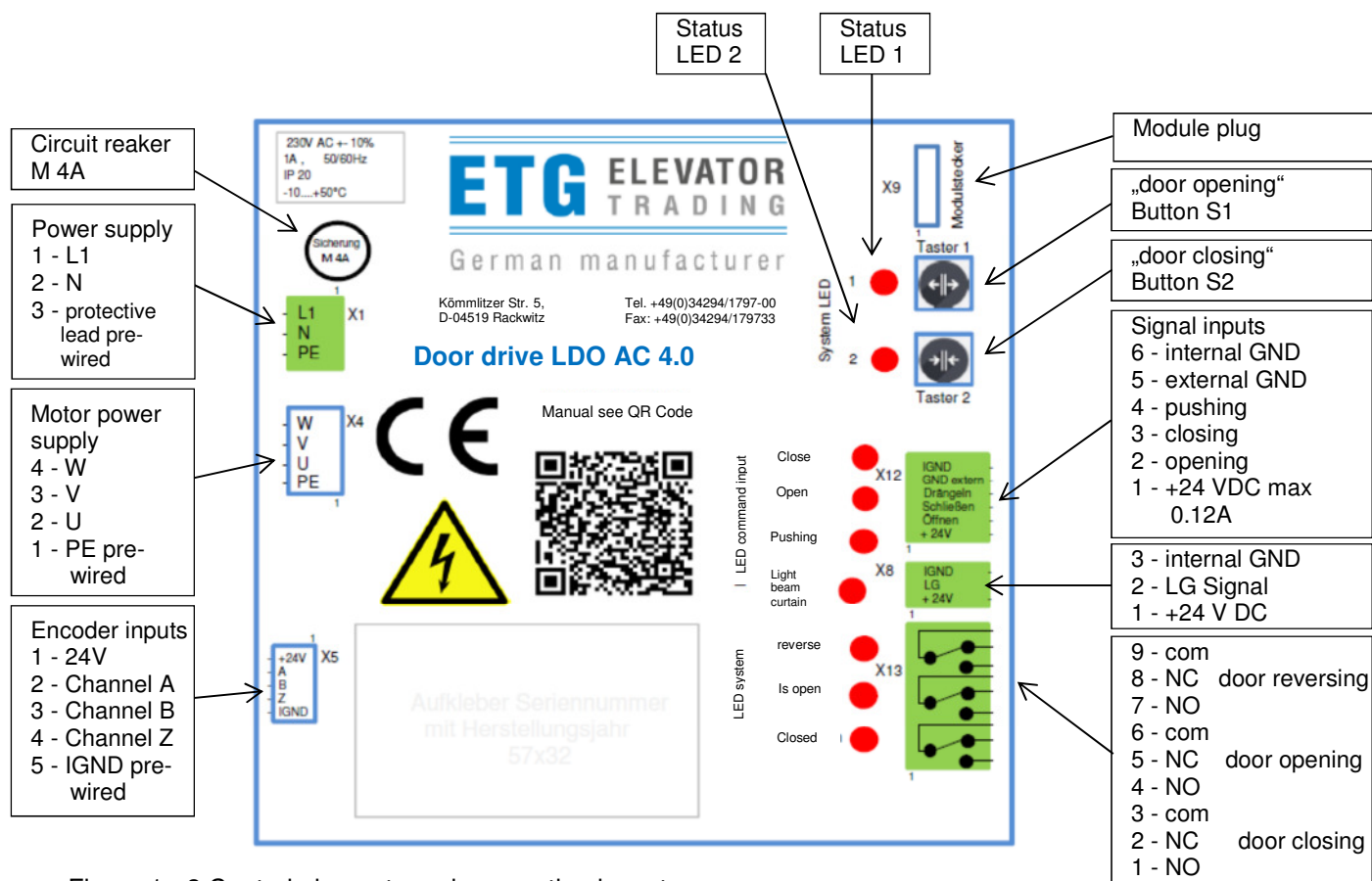

Figure 1 - 2 Control elements and connection layouts

Service buttons „door opening“ and „door closing“:

Both service buttons „door opening“ and „door closing“ allow the door to be moved in both directions. The motion is being performed whilst the button remains pressed.

Description of basic configuration (configuration, see 4.4)

Paragraph 1: Setting door opening type

This parameter specifies, whether the basic parameter should be loaded for a door opening to one side or in the middle into the main memory during door width estimation.

Paragraph 2: Auto-resetting motion

This parameter specifies, whether the door moves to the first end limiter only upon a pulse or upon a continuous signal after a reset or after a power outage.

Paragraph 3: Door type parameter

This enables additional functions, applicable to glass doors according to EN 81. Paragraph 3 enables the door type – metal sheet or glass doors – to be specified.

Paragraph 4: Configuration with / without a cabin door lock

Paragraph 4 specifies, whether ground parameters of the motion curve should be loaded with or without a cabin door lock into the main memory during door width estimation.

3. Technical data

In general	LDO AC 4.0	LDO AC 4.5
permitted door panel weight	max. 200 kg	max. 450 kg
permitted door width		max. 6000 mm
permitted working temperature		max. 50 °C min. -10 °C
Housing	zinc-plated, foot installation with a plastic cover	
Version	IP 20	
Protection rating	IP 20	
Dimensions	W/H/L 330mm/200mm/90mm	
Control system	230 V AC -15% / +10%; 50 Hz □5%	
Power supply	+ 12 V to + 27 V DC; 5 mA per input	
Control inputs	24 V DC, maks. 0.12A protected with a polyswitch	
Control outputs	female connector (Phönix)	
Terminals		
Permanent exciter synchronous motor		
Protection rating		IP 54
Power voltage		230 V
Rated current	0.65 A	1.3 A (max. <=3,5 A)
Power	0.105 kW	0.13 kW
Rated frequency		50 Hz
Weight	2.0 kg	4.5 kg
Power transmission		toothed belt and pulley
Tooth profile width:	12 mm	15 mm
Tooth number:	16	28
Encoder	Rotary encoder with contactless sensor technology	
Incremental encoder	IP 54	
Protection rating:	+24 V DC ±5%	
Power voltage:		

4 Assembly and installation

4.1. Mechanical assembly

Parts of the door drive system should be installed according to local conditions or requirements, at the cabin door. The motor, if it has not been already installed, should be installed at the provided location, using the provided fixing element. Threaded holes are provided in the transverse support for the control unit housing (not applicable to M3000), but it can also be installed in the area of 1.0m around the motor, on the cabin ceiling. Electric installation of the motor, the encoder and the power supply is not prepared and provided with replaceable, plugged connections. Plugs should be attached to X1, X4 and X5 sockets.

- The motor cable should be connected to the X4 socket
- The encoder cable should be connected to the X5 socket
- The power cable should be connected to the X1 socket

4.2. Power supply connection



The power supply cable should be provided at the structure with a 3 A/B cable safety switch or with a power switch (motor safety switch) 1.6 to 2.4 A in the case of LDO AC 4.0, or respectively up to 4 A in case of LDO AC 4.5.

4.3. Switching the power supply on

- first start-up

During the first start-up, the motor performs rotor synchronisation. Basic configuration should be set next, using button 1 (off) or 2 (on). Four paragraphs of the basic configuration are signalled with blinking LEDs next to buttons 1 and 2. The four different blinking frequencies indicate the four following points (fast blinking: paragraph 1, moderate blinking: paragraph 2, slow blinking: paragraph 3 and very slow blinking: paragraph 4). Selection should be made within 15 seconds. The selection, made using a button (1 or 2), is indicated by a LED lighting up next to the button. The configuration then switches to the next paragraph. The default value is selected automatically after 15 seconds if no selection is made. Once all four paragraphs are set, both status LED switch off, the basic procedure is set and the door width evaluation procedure can begin.

- subsequent start-ups

See p. 4.6 Positioning after a power outage or a power supply disconnection.

4.4. Configuration and door width estimation

4.4.1. Description

Door panel weight evaluation is performed together with the door width estimation procedure. Thus, the door width estimation procedure should be performed **together with the shaft door**. The door width estimation procedure may yield exact results, if both mechanical end limiters (rubber buffers for “door open” and “door closed” positions) are set according to the door width. The door control system holds these set limiters as “closing edge” and “door open position” parameters. In order to determine the moving mass, accelerated motions are performed briefly in the opening and in the closing direction. Evaluation of both these motions allows the moving mass to be determined. Using this determined value and the selected basic configuration leads to selection of a pre-programmed motion curve from the available matrix. During the door width estimation procedure, the “closing edge” is determined first, followed by its motion into the “door open” position. Both these positions are stored in the memory and available after a power outage.

Warning!

All modified parameter values are overwritten with standard parameter values during each door width determination! **Always note all modified parameters before proceeding!**

4.4.2. Setting up configuration and door width estimation without a dongle

The door width evaluation procedure may be performed only after a configuration reset followed by setting the four configuration paragraphs.

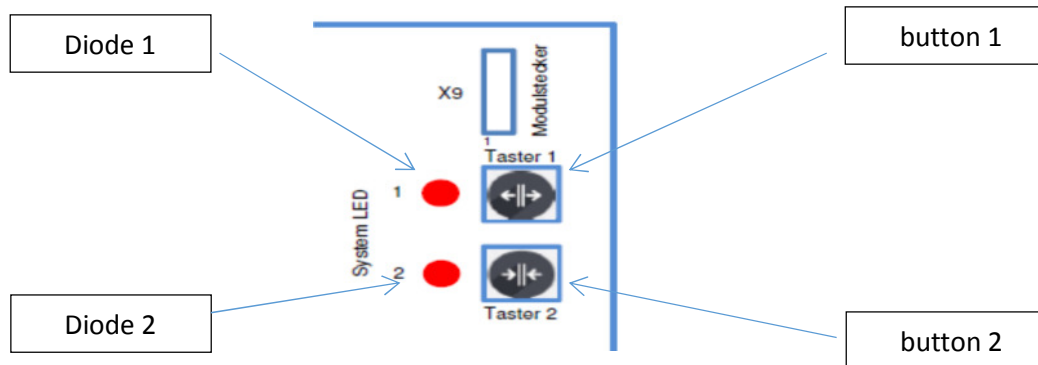

Figure 3 – 4

Step 1: Configuration reset

Press and hold both buttons (button 1 and 2) until both LEDs located next to the buttons are no longer lit up.

Step 2: Configuration

Set all four paragraphs of the configuration procedure, each paragraph should take place within max. 15 seconds, otherwise the default value will be set and the procedure will proceed to the next paragraph.

Basic configuration selection		Setting options	Default value
p.		Button 1 – Button 2	
1	Door opening type	“one-sided” – “middle”	“one-sided”
2	Trigger for auto-reset motion after a power outage	“Pulse” – “Signal”	“Pulse”
3	Door type	“Metal sheet door” – “Glass door”	“Metal sheet door”
4	Cabin door lock	“With CDL” – “Without CDL”	“With CDL”

set during the first blinking (fast blinking) using button 1 as “one-sided door” or with button 2 as “middle-opened door”

set during the second blinking (moderate blinking) using button 1 “Pulse” or button 2 “Continuous signal”

set during the third blinking (slow blinking) using button 1 “Metal sheet door” or button 2 “Glass door”

set during the fourth blinking (very slow blinking) using button 1 “With CDL” or button 2 “Without CDL”

Each time a button is pressed, the LED located next to it is lit up, the LEDs switch off once the configuration is set.

Step 3: Door width evaluation

Position shaft and cabin door approx. 5 to 10mm away from the “closing edge” position.

Press button 1 and switch to button 2 within 0.8 sec, then hold button 2 pressed

Button 2 can be released as soon as the door starts moving.

The following functions are then executed automatically. The door moves ca. 20 cm in any direction, if it does not detect a limiter along the distance, it changes the direction and moves ca. 40 cm in the opposite direction, or until it reaches a limiter. The limiter determines the closing edge position for the control system. This is followed by an opening option determining the “door open” position. The control system accelerates the door along this section in order to determine its mass. The control system records the position at the limiter and moves into the “door closed” direction. Accelerated sections are also used during this motion and used for mass determination. The door stops once the closed position is reached. Status LED 1 is lit up during the door width estimation procedure. At the end of the door width estimation procedure, blinking of LED 2 confirms that normal operation of the door has been resumed.

If the door does not reach a limiter along the 40cm section after it reversed its direction, it is stopped and an error message “quick blinking LED1, very slow blinking LED2” is indicated. The door width estimation procedure must be repeated. The door position should be set again (as described above in paragraph 3) and a new config-reset has to be made (please see above step 1-3).

Service button “door close” and “door open”

The door can be closed and opened with help of the buttons 1 (“door open”) and 2 (“door close”). The door is moving as long as the buttons 1 and 2 will be pressed. The service buttons are positioned parallel to the control input X12.

4.5. Sending lift control messages and status output signals to the lift control system

Input signals “open”, “close”, “push” and “light curtain” are switched using plugs X12 and X8, at the respective pins, see figure 4-4.

Input voltage at X12, pin 2-4 and X8, pin 2: +10V to +30V, max. 10A per input

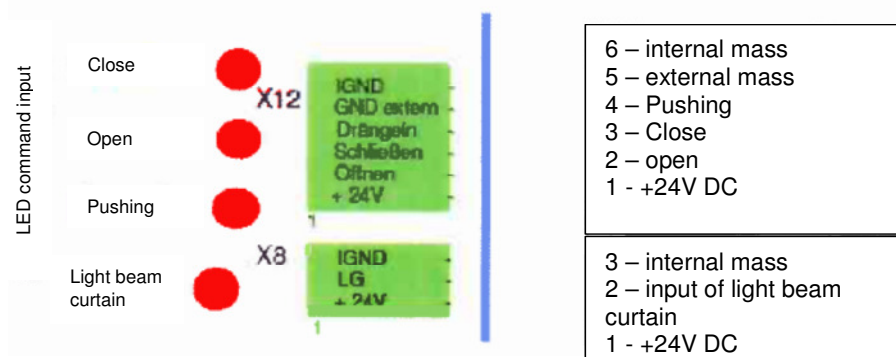

Figure 4-4 Control signal inputs

Note!

The 24VDC at X12, pin 1 and X8, pin 1, are intended as voltage outputs for relay input switching (if required). They should not be used as a light curtain power supply or for other purposes. **Max. load is 120 mA!**

If the internal 24V power supply is used, an internal bridge between the internal and the external mass, pin 5 and 6 at X12 should be used.

If external voltages are used, a connection should be provided at the input, between the external mass and the 0V of the external power supply.

Status signal required by the lift control system “open”, “close” and “reversing” are sent by the door drive unit and can be read at the potential-free relay contacts, plug X13 (see figure 4-5).

Relay contact “closed”

When the door is closed, the appropriate closing element contact at plug X13 is closed (pins 1 and 3) and the opening element contact is open (pins 2 and 3). If the door is not closed, the closing element contact is open and the opening element contact is closed.

Relay contact “open”

When the door is open, the appropriate closing element contact at plug X13 is closed (pins 4 and 6) and the opening element contact is open (pins 5 and 6). If the door is not open, the closing element contact is open and the opening element contact is closed.

Relay contact “reversing”

When the door is reversing, the appropriate closing element contact at plug X13 is closed (pins 7 and 9) and the opening element contact is open (pins 8 and 9). If the door is not closed, the closing element contact is open and the opening element contact is closed.

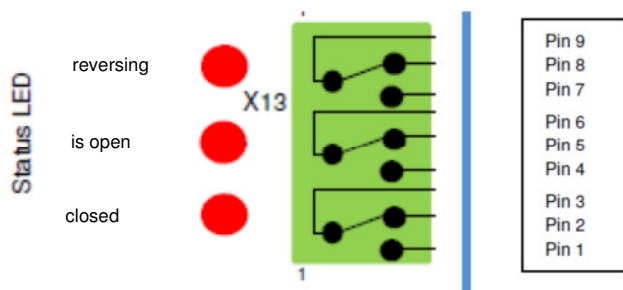

Picture 5-4 Relay contact

Control outputs at connector X13: max. 30V 0.5A

The door drive is now functioning with the preselected parameters. The further parameters can be still changed if necessary. For adjustment of desired running characteristics you can use the paragraph 5 “Configuration”.

4.6 Positioning after power breakdown, or respectively after disconnection from supply

After successful rotor synchronization, the door has to run in a final stop in order to determine a position. This action has to be made by a command “door close” or “door open”. This searching of final stop will be indicated by blinking of status LED 1. Depending of which command will be given to the door drive, the door runs in the respective final stop and the door drive changes into the normal operating status. This action will be indicated by blinking of status LED 2 (1 Hz).

5. Configuration (only possible with Dongle)

The following parameters can be used in order to control the door drive:

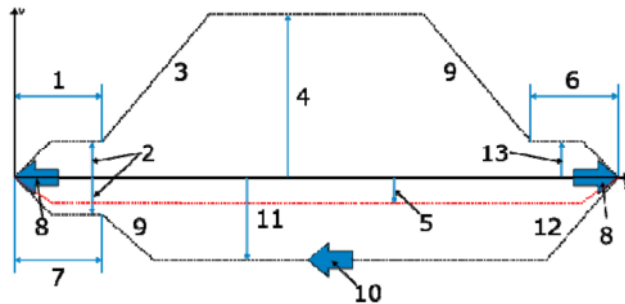

Figure 6 – 4 Motion curve diagram

Parameter	Description		
1	Blade distance „door opening“		
2	Low speed „closing edge“		
3	Acceleration ramp „door opening“		
4	Speed „door opening“		
5	Pushing speed		
6	Slow motion distance „door opening“		
7	Blade distance „door closing“		
8	Holding force		
9	Deceleration ramp		
10	Closing force		
11	Speed „door closing“		
12	Acceleration ramp „door closing“		
13	Low speed „door opening“		



The maximum static closing force of 150 N should not be exceeded.

6. The encoder

The encoder is installed in the motor housing. Changing its settings and maintenance works are not possible.

7. Error message

Error	Cause	Remedy
The door does not move	No power supply	Check the power supply connection
	No commands from the lift control system	-check signal inputs and mass contacts -PIN 5 and 6 at connector X6 must be bypassed at relay control -check the signal input voltage
The motion direction does not correspond to the „door opening“ and „door closing“ buttons.	-door width determination has been started from wrong starting position -the control system does not recognize door data	The door width determination should be repeated

The door does not find a position.	No door width determination has been made.	Readjust mechanic limit stops "door close" and "door open", make a new door with determination
The door stops while closing and opens again.	The door motion is difficult	Check mechanical settings
The door is jerking only when there's a pending command.	The encoder-control system connection is faulty	Check the encoder cable connector
Door opens or closes at low speed	No door width determination has been made.	Readjust mechanic limit stops "door close" and "door open", make a new door with determination
	The control system does not recognize the door position	The "door closing" command is present until the door control system reports the "door closed" state.
The door doesn't stop in the final stops, but moves a little bit back	The cause is by rote, final stops are wrongly adjusted or weren't reached.	Check the final stops and adjust.

Error indications using LEDs

Error	Meaning	Blinkcode Status-LED 1 Blinking	Blinkcode Status-LED 2 Blinking	Remedy
Excessive temperature	Ambient temperature exceeds the permitted range	fast	very slow	
Temperature too low	Ambient temperature is below the permitted range	fast	very slow	
Overvoltage	Intermediate circuit voltage exceeds the permitted range	fast	very slow	
Voltage too low	Intermediate circuit voltage is lower than the permitted range	fast	very slow	
Short-circuit at the motor	The power module detects a short-circuit current	fast	very slow	Motor is faulty and must be replaced
Ovecurrent	The motor current exceeds the permitted current value	fast	fast	
Door width determination error	No closing edges are recognized	fast	very slow	
Error recognised during self-test		very slow	very slow	Control system is faulty and must be replaced
Error at internal component testing	Component error	slow	fast	Control system is faulty and must be replaced
No existing programme	Programme has been deleted from memory	fast	fast (not synchronous)	Make a softwareupdate

Very slow = 0.5 Hz, slow = 1 Hz, fast = 2 Hz, very fast = 4 Hz

Acknowledge error:

Errors can be acknowledged by resetting the configuration.

The following errors „Excessive temperature“, „Temperature too low“, „Overvoltage“, „Voltage too low“, „Short-circuit at the motor“ and „Overcurrent“ are acknowledged internally after ca. 18 seconds. The self-test of the control system is started next. If the error is no longer present, the door control system continues to operate normally. If the error is still present, the door control system enters a „Self-test error“ condition. If the working temperature is outside the specified range, the control system resumes its operation only after reaching its normal temperature.

8. WLAN Dongle

8.1 Configuration using WLAN Dongle

The WLAN Dongle is required for precise adjustments of the motion curve. It is connected to the module plug. A connection to the dongle should be made using a WLAN-enabled device. No commands of the control system are accepted when the dongle is connected. Only both "door opening" and "door closing" buttons may be operated.

- Connect the device to the „LDO AC 4.0/4.5“ network with password (cf. sticker on WLAN Dongle)

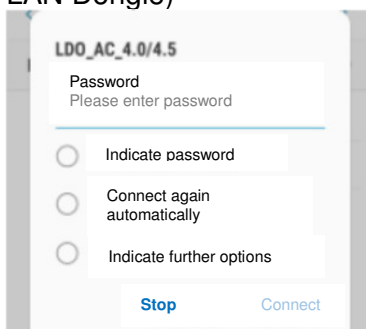

- Open the browser and set a connection to the IP address 192.168.1.3
- You have to enter and confirm the same password in the 1st window of servicing level (see sticker of Dongle)

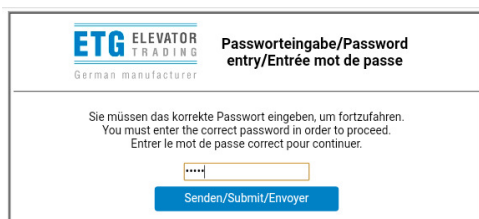

- The next page is an overview page enabling language selection, providing a quick start guide, a parameter overview and a setting overview.



The settings page allows the 4 DIP switches to be set.

- In case of cabin doors for which the door width recognition procedure may not be performed from the roof (smaller overhead pulley), it allows the procedure to be performed using the dongle.
- Individual parameters are available by direct selection or by subpages available on parameter pages.

- Parameter values may be changed by pressing „+“ or „-“ buttons or by providing values in the view window. The „Set“ option accepts the introduced values.
- The dongle also allows installation of future updates in the control system.

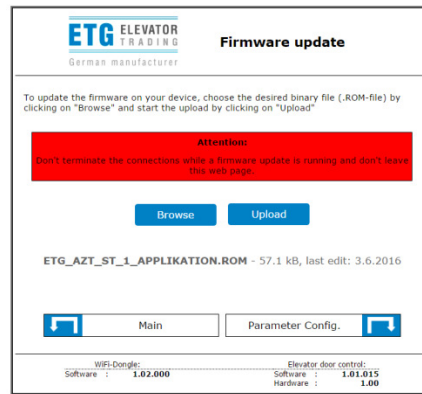
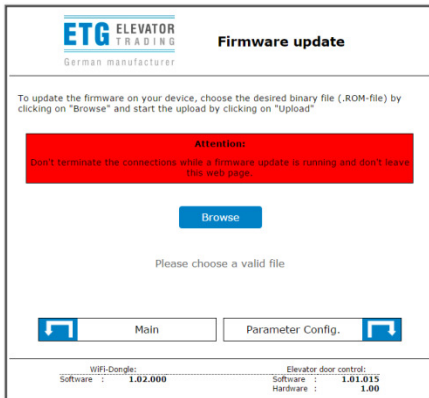

- The current version of the software should be first downloaded from our homepage and saved on the device. The Browse button opens the Explorer in order to search the desired file and to mark the software.
- Marking the Upload field causes the update to be installed.

8.2 Error messages during work using WLAN Dongle

Example error messages

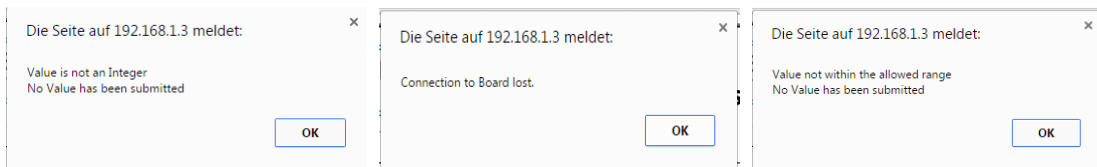

Errors and messages

Error message	
Connection to Board lost	
Value is not an Integer NoValue has been submitted	
Value not within the allowed range NoValue has been submitted	
No valid Firmware on controller. Please do a Firwareupdate first.	
Update successful	
Update failed	

Set values:

P1

P2

P3

P4

P5

P6

P7

P8

P9

P10

P11

P12

P13

DIP 1

DIP 2

DIP 3

DIP 4

Elements of the complete control unit

LDO AC 4.0/4.5 control unit

Motor for LDO AC 4.0/4.5

Optional toothed belts (m4 doors)

Accessories	Part no.:	Product	pcs.
<input type="checkbox"/> Bag of screws	27120043	Cable tie	6
	50110023	Verbus Ripp M6 nut M6	4
	50105310	Verbus Ripp screw M6x12 8.8 zn	4
<input type="checkbox"/> Optional bag of plugs	50100098	Feeder with connector 3-pin, connector 3/6/9	1 each 1

