

### 13. Nominal and emergency power supply

For normal operation the drive is powered from typical power supply line 230V 50Hz. The built-in transformer reduces the voltage to the value of 19V required by the electronic board.

The drive can also be power from an emergency power supply from:

- An external battery connected to terminals +ACU and - ACU. In this case the drive provides the battery loading while the main power in on.
- An external emergency power supply of 12V connector to terminals +12V and ACU (the battery loading function is not supported).

No	Parameters	Description	Range
16	Emergency close	Maximum time for keeping a door closed while powered from an emergency source.	1-90 min



**Handle the board as an industrial waste when disposing of it.**

## 10. Learning mode (factory settings)

No	Parameters	Description	Range
06	V learn opening	Door speed during learning mode	12-25%
11	Learning torque	Maximum torque during learning mode	35-60%

### ⚠ CAUTION!

Too high vale may lead to the generation of high forces in a mechanical drive.

Too low values may cause the wrong setting of the door width.

No	Parameters	Description	Range
19	Revol. direction	Motor revolutions direction during opening	left - right

### ⚠ CAUTION!

In case of MASTER/SLAVE operation make sure that this parameter on MASTER and SLAVE drives are set into opposite values.

No	Parameters	Description	Range
66	Automatic opening	Automatic reverse operation	0-1

If an obstacle is detected during door closing the drive will stop and it wait for an opening signal. If it is not received during several seconds the door drive will reset. If this function is set the drive will automatically start door opening.

## 11. User interface

No	Settings	Description	Range
52	Password part 1	The access to all parameters can require entering a password. If both values are set to 00, all the parameters can be accessed freely.	00-99
53	Password part 2		00-99
54	Menu language	Enables menu language change	Polish English Italian

## 12. Speed regulator parameters (factory settings – DO NOT CHANGE!)

No	Settings	Description	Range
62	Kp	Proportional controller gain factor	8-14 %
63	Ki	Integral controller gain factor	8-15%
64	Kd	Derivative controller gain factor	0-5%

## 8. Settings of the fully open door position

No	Parameters	Description	Range
10	Opening limit	The point to stop the door opening.	1-10 x 0,5 cm

The drive enables to stop the door at the specified open position.

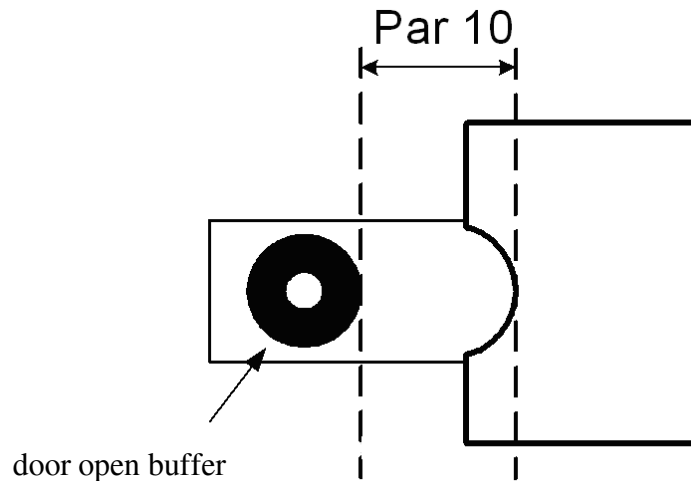

## 9. Re-open function settings

No	Parameters	Description	Range
00	Re-open dynamic	Speed decrease while changing direction	70-95%

This parameter determines the speed decreasing after the door closing signal is removed due to reopen them. This situation takes place, for example, when a photocell detects an obstacle during closing or door open button is pressed.

### ⚠ CAUTION!

Too high value for a heavy door may cause belt slipping while changing the movement direction from closing to a door opening.

No	Parameters	Description	Range
20	Max closing tg	Maximum closing torque	50-60%

This parameter determines the maximum value of the force produced to close the door. While detecting an obstacle, the drive closing torque is limited to this value.

Setting this value too low may reduce the door closing dynamics, so the required door closing speed can be hardly achieved.

No	Parameters	Description	Range
17	Reference hold	Speed reference hold time	0-90% x 10s

The time that the door keeps running on nominal speed after an obstacle has been detected.

## 7. Settings of door drive opening parameters

With the following set of parameters it is possible to change door operation during opening. All the parameters are described due to door travel opening curve adjustment.

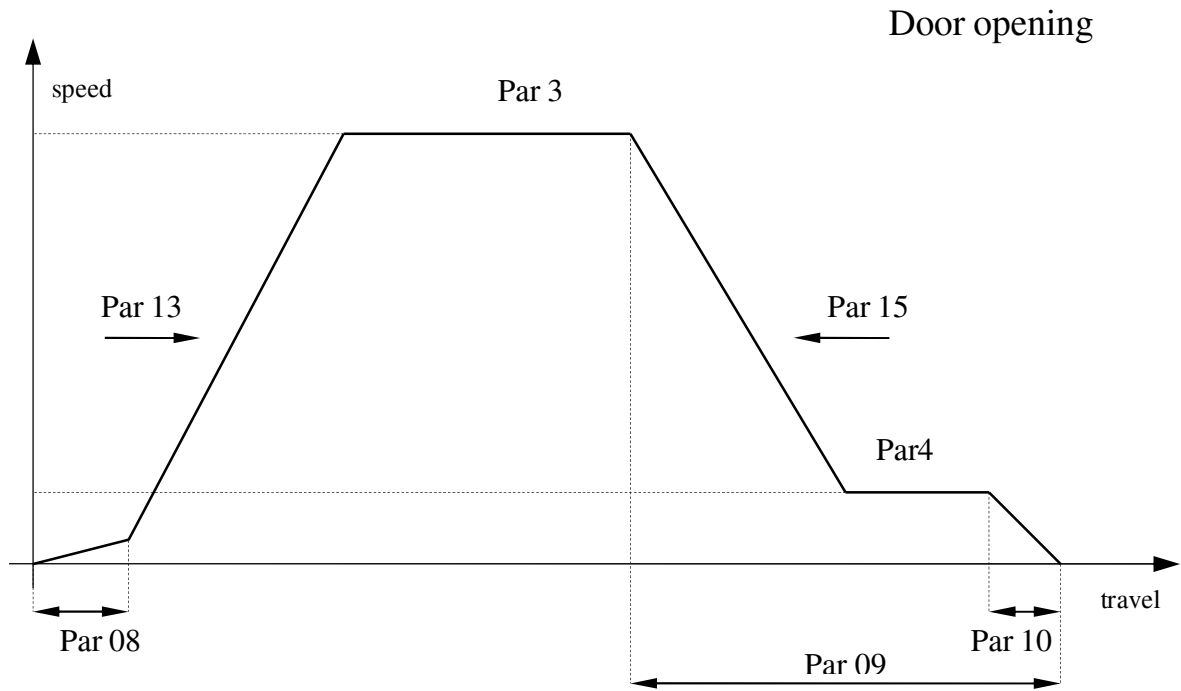

No	Parameters	Description	Range
08	Retiring cam	The point of travel when the locking cam is operated (the reverse operation is disabled).	16 or 21 x 0,5 cm

### ⚠ CAUTION!

Specifying the exact length of a door cam action is required to prevent against too much torque generation that could increase the noise.

No	Parameters	Description	Range
03	V rated opening	Door opening nominal speed	40-80%
04	V final opening	Door opening speed at the end of travel	5-20%
09	Opening dec	The point to change the speed from 03 to 04	20-80 x 0,5 cm

Setting the braking point too close to the door opened position results in reaching the opened position too quickly, and consequently impact.

Too high value cause too early door braking and consequently unnecessary extension of a door opening travel.

No	Parameters	Description	Range
13	Start opening torque	Speed increase during opening	40-95%
15	Break opening torque	Speed decrease from 01 to 02 during opening	60-100%

## 6. Settings of door drive closing parameters

With the following set of parameters it is possible to change door operation during closing. All the parameters are described due to door travel closing curve adjustment.

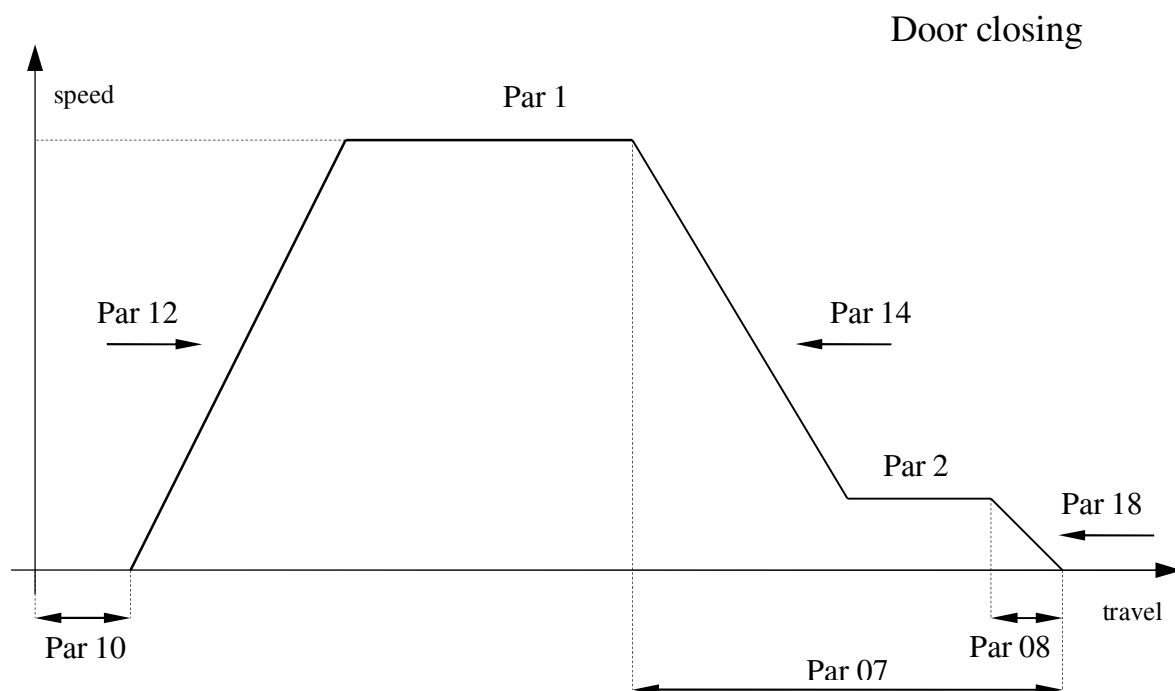

No	Parameters	Description	Range
08	Retiring cam	The point of travel when the locking cam is operated (the reverse operation is disabled).	16 or 21 x 0,5 cm
18	Locking speed	Locking cam speed at the end of closing	50-99%

At this point the doors are closed and the motor moves the door cam only. It is required to specify the exact length of the cam action to disable door reverse function in case of detection of an obstacle.

### ⚠ CAUTION!

If a parameter value is too high, the control unit recognizes the doors closed too early and did not react, for example, when a hand is put between the doors.

No	Parameters	Description	Range
01	V rated closing	Door closing nominal speed	30-50%
02	V final closing	Door closing speed at the end of travel	2-15%
07	Closing dec	The point to change the speed from 01 to 02	20-50 x 0,5 cm

Setting the breaking point too close to the door closed position results in reaching the closed position too quickly, and consequently impact.

Too high value cause too early door braking and consequently unnecessary extension of a door closing travel.

No	Parameters	Description	Range
12	Start closing torque	Speed increase during closing	40-95%
14	Break closing torque	Speed decrease from 01 to 02 during closing	60-100%

#### 4. Start-up: self-learning

Since the door movement speed depend on its relative position between the fully open and close limits, it is necessary to precisely set up the door width. This data is established during a special self-learning procedure and the values are stored in a controller EEPROM memory.

No	Settings	Description	Range
55	Door width	Part 1	Automatic
56	Door width	Part 2	Automatic

Before putting the drive into normal operation or on case on any not correct opening or closing, please follow the steps below to carry out a self-learning procedure:

- set both parameters 55 and 56 to 0,
- set a correct opening direction in parameter 19,
- disconnect the drive for at least 10 seconds, then switch power on,
- a door self-learning procedure will start automatically,
- at the end the door will be closed, the established values will be written to door width parameters and the door is ready to work.

#### ⚠ CAUTION!

After self-learning procedure is completed, it necessary to confirm the established values of parameters 55 and 56. Only after confirmation they will be written to the controller memory!

#### 5. Door drive control

The door drive is controlled by putting a voltage signal in range from +12V to +24V to its input terminals:

IN1 input: door close command  
 IN2 input: door open command

The information about the door positions can be read from drive relays on the following outputs:

K1 relay: door closed contact  
 K2 relay: door closed contact  
 K3 relay: door reverse contact

If the door controller is working together with LS-2020 lift controller it is possible to establish data exchange via LIFTCAN bus, so no other control signals are required.

No	Settings	Description	Range
50	LIFTCAN address	This parameter enables control via LIFTCAN for working together with LS-2020 lift controller	- off - main side, passage and third
51	Operation mode	This allows change the operation from normal mode into manual (the drive works with up and down pushbuttons) or demo mode.	- normal - manual - demo
57	Relay K1	Relay type (0-NO, 1-NC) (0-normally open, 1-normally close)	0-1
58	Relay K2	Relay type (0-NO, 1-NC)	0-1
59	Relay K3	Relay type (0-NO, 1-NC)	0-1

#### ⚠ CAUTION!

After all maintenance is done, make sure that the controller has been switched into normal mode!

## 2. Main screen information

nxx	v00%	L9999
i0000	o0000	[ ]

n – operation mode (n normal, m manual, d demo), xx – program phase  
 v – motor speed, L – door position, i0000 – inputs, o0000 – output relays,  
 [ ] door is opened, [ [ door opening, ] ] door closing, ] [ door is closed  
 Pressing ESC button will change the lower line into internal variables information:

nxx	v00%	L9999
c00v28e00-00pr00		

c – motor current, v – power supply voltage, e - number of encoder errors,  
 +/- door movement direction and current integral value, pr – motor rotation speed

## 3. Motor tuning (factory settings)

Because F(ield) O(riented) C(ontrol) system has to know exact position of the rotor, the special procedure has to be performed to determine the relative position of the rotor and the encoder. The offset value is characteristic for every engine leaving the factory.

### ⚠ CAUTION!

Motor tuning procedure is made in the factory. It is required to perform it on the site only after encoder replacement or mechanical regulation of its position.

No	Settings	Description	Range
05	Pole pairs	Number of motor poles	3-4
60	Motor tuning	Part 1	Automatic
61	Motor tuning	Part 2	Automatic

### Wrong data will cause the malfunction of the drive!

To perform motor tuning procedure, please follow the steps below:

- take off the motor belt (auto-tuning procedure has to be performed without any motor load),
- check if motor pole pairs parameter is set correctly,
- set both parameters 60 and 61 to 0,
- disconnect the drive for at least 10 seconds, then switch power on,
- motor tuning procedure will start automatically and correct values will be written to motor tuning parameters.

### ⚠ CAUTION!

After motor auto-tuning is completed, it is necessary to confirm the established values of parameters 60 and 61. Only after confirmation they will be written to the controller memory!



# Lift Door Drive LS-SDK2

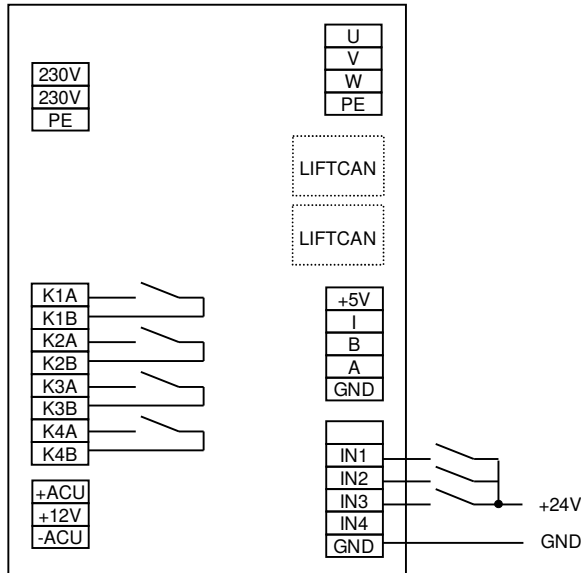

**Power supply:** 230V 50Hz  
**Emergency power supply:** 12VDC  
**Motor terminals:** U, V, W, PE  
**Encoder terminals:** +5V, I, B, A, GND

**Inputs:**

IN1 door close command  
 IN2 door open command  
 IN3 fire input (EN81-72 5.8.6)  
 IN4 lift error, door stopped

**Outputs:**

K1 door closed contact  
 K2 door opened contact  
 K3 door reverse contact  
 K4 not used yet

**The door motor is protected against overheating by current limitation.**

## 1. Start-up instructions

Install the door drive on the car roof.

⚠ CAUTION!

Do not connect the motor power supply and the encoder wiring yet.

Check if the door can be manually opened and closed without any mechanical resistance. Connect the motor power supply and encoder cables.

⚠ CAUTION!

Do not connect any control wiring to the door drive inputs yet (or LIFTCAN).

Switch on the door drive power supply. The door controller should start closing the door. When the door is closed the controller is ready for control commands.

It is recommended to check if the door are working properly in the following way:

- Press ENTER, using UP and DOWN buttons set pointer position to SETTINGS,
- Press ENTER, using UP and DOWN buttons look for parameter 51,
- Press ENTER, using UP and DOWN buttons change operation mode to manual,
- Confirm your choice pressing ENTER.

In this mode you can give open and close commands by pressing UP and DOWN buttons. Check if the door are working properly. If not, start self-learning procedure (chapter 4).

⚠ CAUTION!

After test operations make sure you have changed operation mode to normal (parameter 51).

Now connect control signals from the lift controller to the door drive terminals (or LIFTCAN).

⚠ CAUTION!

In case of LIFTCAN control make sure that the proper door drive address is set (parameter 50).