

DESCRIPTION

The NC80 and NC82 safety relays are created for use in safety circuit intended by EN 81-20 and EN81-50.

NC80 and NC82 units are specifically designed to be used in safety circuits for elevators, in particular they can perform the following functions:

- part of a UCM device (**function1**)
- bypass of door contacts during levelling and re-levelling operation with doors open (**function2**)
- locking devices for automatic and hinged floor and car doors in combination with magnetic sensors N520 H D/E, N520 F P/H, N52H H2, N300 H A/G, N300 FH, N30H H2, N550 H D/E, N550 F P/H, N557 H D/E, N557 FP/H, and magnetic actuators M125, M128, M113 e M15x (**function 3**)

Function 2: bypass of the elevator doors contacts during the levelling operation

The module is equipped with two control inputs S1 and S2 which, if activated in a time interval of 1.8s or 3.2s cause the switching of the three outputs, two of which are normally open and one normally closed.

The output remains active until the two inputs are closed (see time chart). Safety is guaranteed by the use of guided contacts, redundancy and the connection scheme of the contacts.

Function3: Door locking devices

The NC80-NC82 modules have two control inputs S1 and S2 that, if activated in a time gap ts, leads to the commutation of the three outputs (2 normally open and one normally closed).

Inside each individual sensor, combined with the doors system, there are multiple contacts that guarantee the redundancy of the system and provide the output of the equivalent of two N.O. signals. The N.O. signal referred to the brown and white cables have to be connected in series with the contacts referred to the same cables on the other sensors. The same thing have to be done for the N.O. signals referred to the yellow (blue) and green (black) cables. In this way, two independent chains of N.O. contacts are obtained, which constitute the inputs of the NC80-NC82 control units. When both sensor chains provide, within a ts time interval (see technical data table) two CLOSED signals, the control unit activates the safe outputs and the signalling output for the control panel.

The output remains active until the two inputs are closed (see time diagram). The safety is ensured by the use of guided contacts, redundancy and the interconnection scheme of contacts.

The NC82 safety control unit is equipped with an adequate circuitry able to guarantee its correct operation even in case of voltage dips

ASSEMBLY

Installation must be performed by authorized personnel only.

The NC80 or NC82 control units must be assembled in a suitable operating area (switch cabinet, protective housing, at least IP 20).

The control unit is installed by fixing it to a standard 35 mm DIN rail in accordance with EN 50022.

ELECTRICAL CONNECTIONS

Electrical connections should only be made by authorized personnel.

All electrical inputs shall be isolated from the main power supply or by means of a transformer with separate windings in accordance with EN IEC 61558-2-6 with limited output voltage in the event of a defect, or by an equivalent removable mechanism

Terminals A1 and A2 are protected from polarity reversals.

The relay outputs have a maximum allowable current of:

- 3A in case of function 1-2 (UCM-levelling)
- 2A in case of function3 (doors)

PRECAUTIONS

Safety sensors perform a personal protection function. Incorrect installations or manipulations can cause serious damage to the personal.

The system is a component of the whole landing door locking device that have to be homologated in its entirety.

Safety sensors must not be bypassed (short-circuiting contacts), moved, removed or otherwise rendered ineffective.

The manufacturer or installer of the machine is responsible for the correct and safe operation.

The auxiliary output 41/42 of this control unit should not be used as a safety output.

FOR USE ON DOORS, THE SYSTEM GUARANTEES SAFETY WHEN USED IN ITS ENTIRETY: CONTROL UNIT AND SENSORS USED INDIVIDUALLY DO NOT CONSTITUTE SAFETY ELEMENTS.

Also carefully read the safety requirements contained in the manual: "IP67 door safety system - operating instructions sensors"

OPERATION

Function1: Uncontrolled movement detector

The safety module guarantees the opening of the contacts within 20ms from the opening of the S11-S12 or S21-S22 sensors; therefore, it can be used as a part (detector) of an uncontrolled movement detection system of the cabin in accordance with point 5.6.7.7 of EN 81-20.

Input sensors must comply with EN 81-20 (typically magnetic). The sensor targets must be placed in the door zone and they must have a suitable length to ensure the stopping of the car within 1m from the landing sill as required by EN 81-20. The dimensioning of the length of the magnets is assigned to the end user as a function of the response times of the locking system and the maximum elevator speed.

Being only part of the system, the description of test methods according to EN 81-50 (§ 5.8.3.x) is delegated to the end user.

NC80 - NC82 Timing Diagram

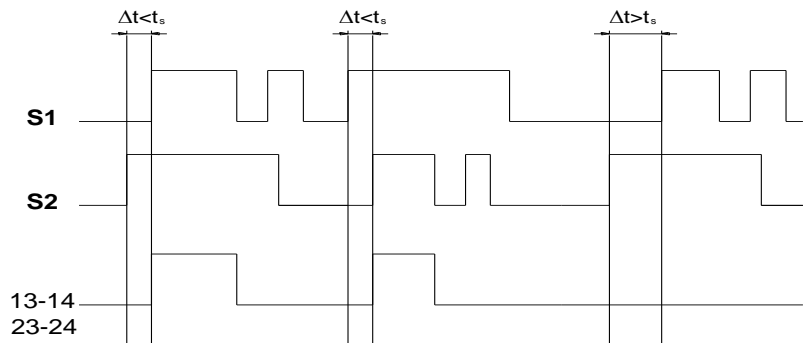

Wiring Diagram

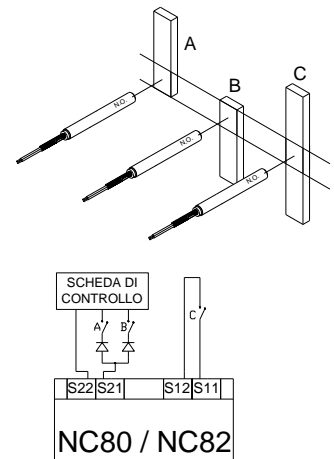
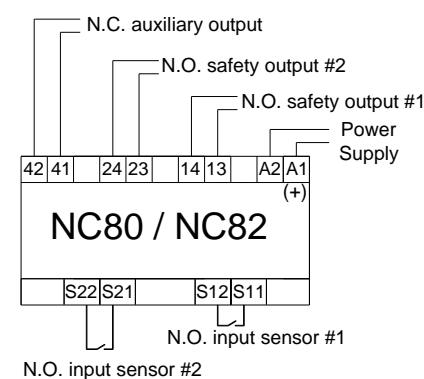

The power supply connected to the outputs shall be protected against overcurrent by devices appropriate for the loads

External fuses can be inserted for safe relay outputs.

All output contacts must have an adequate protection circuit for inductive and capacitive loads.

All inductive and capacitive loads (e.g. relay contacts) connected with the power supply of the control unit must be connected to an appropriate interference and overvoltage suppressor.

The control unit is equipped with protection on the inputs S11-S12, S21-S22 through PTC it is however suggested the use of fast 200 mA fuses connected in series to the input contacts

The coverage of the warranty as well as the manufacturer's liability is lost in the following circumstances:

- if instructions are not read and followed
- non-compliance with safety regulations
- installation and electrical connection not performed by authorized personnel
- non-implementation of periodical functional checks
- product tampering

SETUP

If the control unit appears not to work when the supply voltage is applied (the yellow LED does not light up), the unit must be returned sealed to the manufacturer. Check if the safety outputs switch (see LED table) by activating the two inputs S1, S2.

Prescription for door system IP67:

Sensors connected to doors that open simultaneously cannot be wired in series to the same NC80 or NC82 safety modules. Therefore, it is mandatory to use a control unit for each car door in the event of their simultaneous opening.

It is mandatory to use a control unit for each floor door side when simultaneous opening.

It is mandatory to use a control unit for each side of a double hinged door.

See the examples beside.

DOOR SYSTEM CONNECTION EXAMPLES

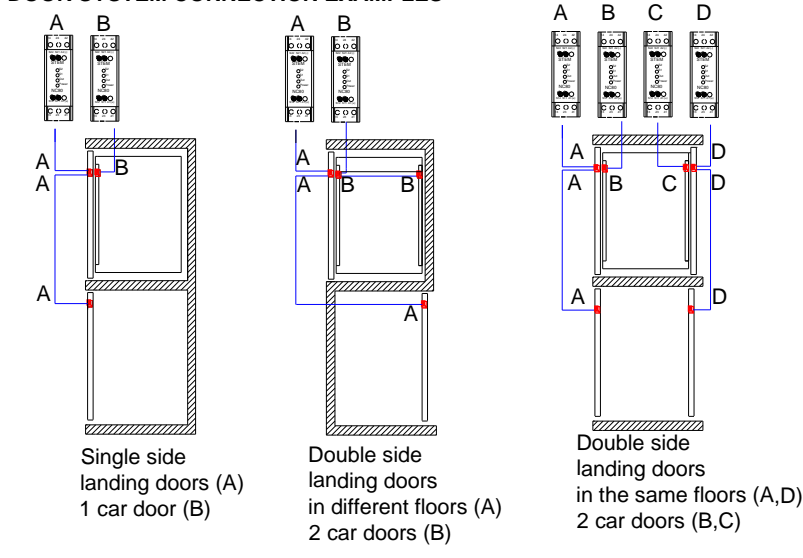

SERVICE AND INSPECTION

The correct functioning of the NC80 or NC82 control unit must be checked by the operator and/or by the control circuit of the lift periodically and every time the control unit is subjected to an off/on switch cycle, checking the following:

- correct switching of the safety output when the sensor is opened
- secure fixing of components
- connection tightening

In the case of function 1 or 2 check:

- a) that when the single sensor is opened, the safety outputs are opened (13-14 / 23-24)
- b) when closing the same sensor, the safety outputs remain open.
- c) the safety output close as a result of a deactivation and activation cycle of both sensors.

The device monitoring function is carried out at each time the device performs an outputs opening/closing cycle.

If at the door area, the control unit does not activate its safety output, then proceed to the verification of any open sensors and perform the checks indicated above in point a), b) and c).

In case of failure or wear, the damaged system must be replaced.

No maintenance is required.

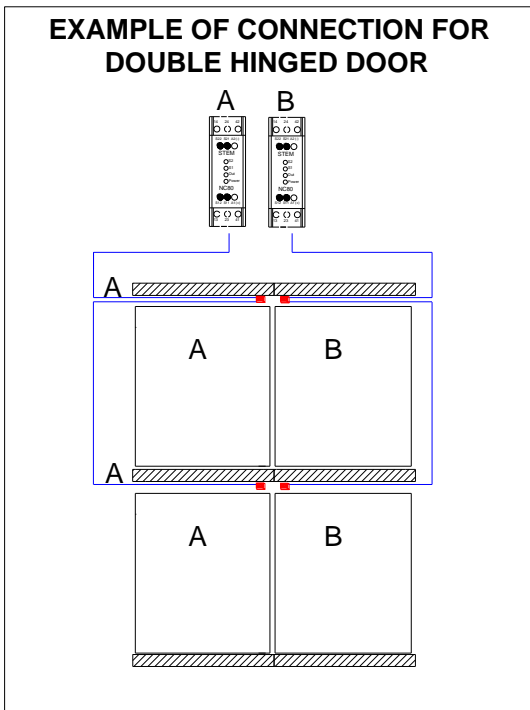

NC80 - NC82 LED table

Led Name	Function	Color	State
Power	Operating voltage	yellow	on
OUT	Outputs 13/14, 23/24 and 41/42: OPEN	red	off
OUT	Outputs 13/14, 23/24 and 41/42: CLOSED	red	on
S1	Inputs S1: OPEN	green	off
S1	Inputs S1: CLOSED	green	on
S2	Inputs S2: OPEN	green	off
S2	Inputs S2: CLOSED	green	on

SENSOR CONNECTION DIAGRAM FOR IP67 DOOR SYSTEM

- Reed sensor connection diagram (N52x Hx, N52x Fx, N30x Hx, N30x FH, N55x Hx, N55x Fx)

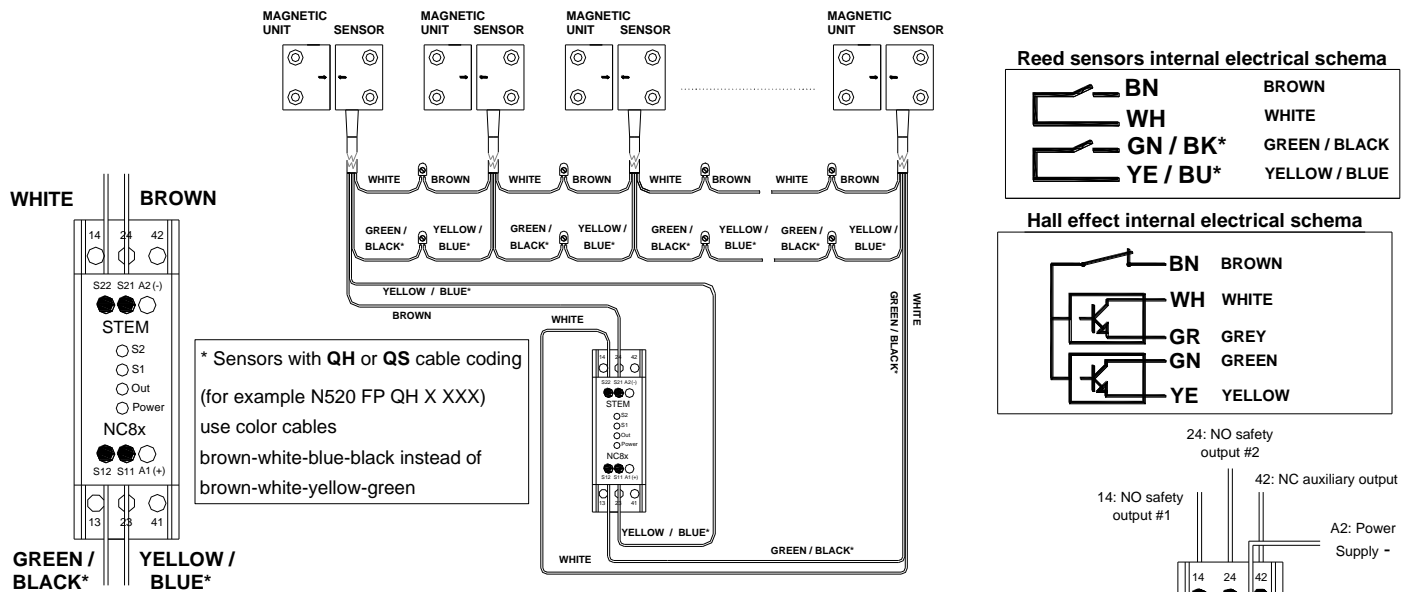

- Hall effect sensors connection diagram (N52H H2, N30H H2)

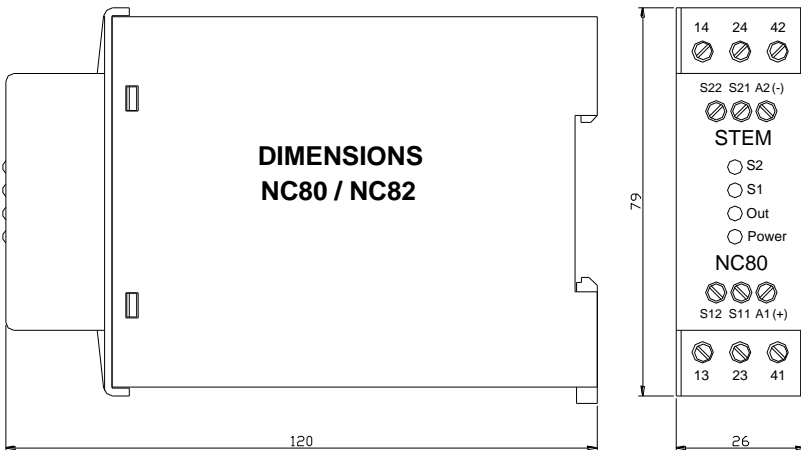
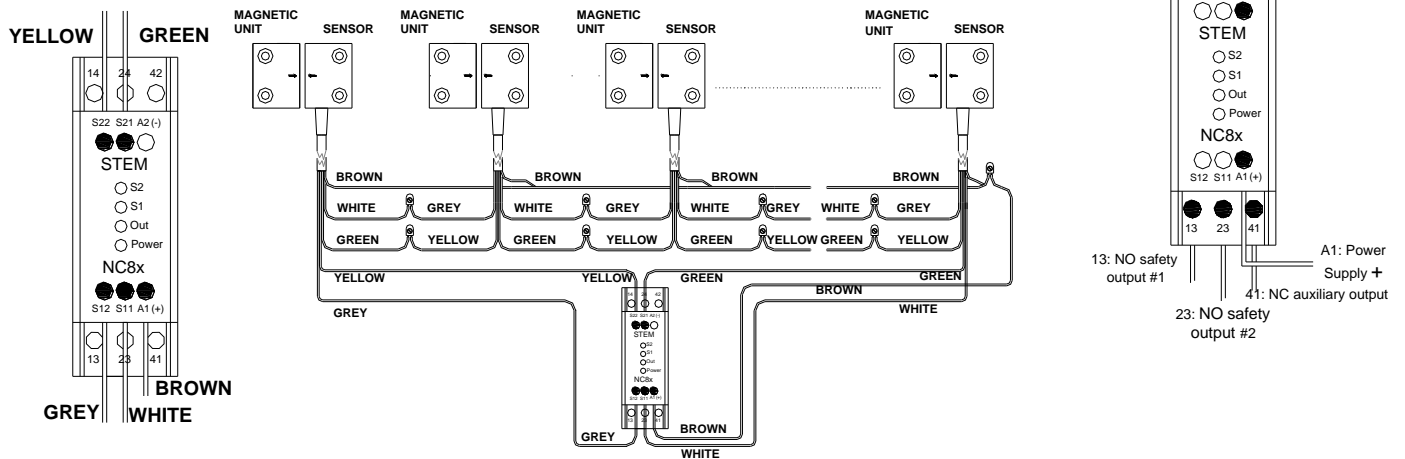

Voltage dip (Valid only for NC82)

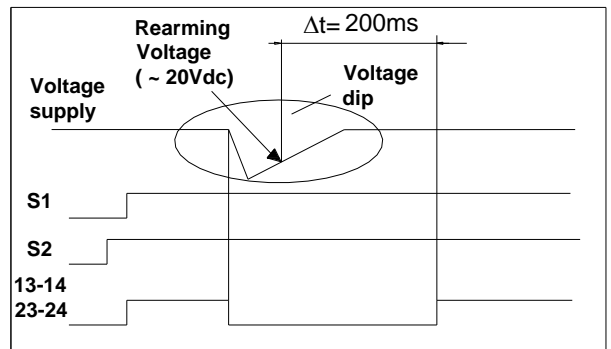

TECHNICAL DATA

Parameter	Value	Unità
Housing Material	Bayblend (Polycarbonate+ABS+fiberglass)	
Dimensions / Weight	120 x 79 x 26 / 185	mm/g
Operating ambient temperature (storage)	0 ... +55 (-25 ... +70)	°C
Degree of protection (IEC 60529)	IP20	
Pollution Degree (EN 60664-1)	3	
Overvoltage Category (EN 60664-1)	III	
Assembly	Standard DIN guide 35 mm (EN50022)	
Connection type	Screw terminals	
Power Supply voltage	24 ±10%	V DC
External fuse on the power supply	250 mA fast (min)	
Current consumption	OUT=off: 50 OUT=on: 100	mA
Max. switching frequency	10	Hz
Input synchronization time (ts):	1,8±20% (standard devices: NC80 - NC82) 3,2±20% (optional devices: NC80320 - NC82320)	s
Closing output response time	50	ms
Opening output response time	20	ms
External fuse on the outputs	3 A fast type	
Safe output terminals	13-14 e 23-24 (normally open)	
Maximum voltage on safe output	250	VAC
Maximum current on safe output	3	A
Maximum switching power on the safe output (AC)	460	VA
Maximum switching power on the safe output (DC)	50	W
Auxiliary output terminals	41-42 (normally closed)	
Auxiliary output voltage	30	VAC
Auxiliary output current	2	A
Auxiliary output power	90	VA
Vibration resistance	In accordance with EN 81-20/50	
Electrical operating life	1x10 ⁶ (230Vac, 3A cosφ1); 2x10 ⁶ (24Vac,2A cosφ1);1x10 ⁶ 48Vdc,2A	Cycles
Mechanical operating life	10 ⁷	Cycles
EMC compliance	EN 12015, EN 12016	
Standard compliance	EN 61508-2:2002 - SIL3, EN 81-20:2020, EN 81-50:2020	
Approval certificate	IMQ n. CA50.00761	

RATINGS FOR IP67 DOOR SYSTEM

Maximum AC voltage and current on safety outputs (13-14 / 23-24)	230Vac - 1,5A EN81-50 Par. 5.2.2.4
Maximum DC voltage and current on safety outputs (13-14 / 23-24)	48Vdc - 1A EN81-50 Par. 5.2.2.4
External fuse on the outputs	1,5A for AC load / 1A for DC load fast type

UL Certification Requirements

Power Source (input)			
Input Terminals	Voltage		Max. Current
A1-A2	NC80 24Vdc	NC82 25Vdc	100mA
Auxiliary Outputs (SAFETY)			
Output Terminals	Contacts Type	General Use or Resistive	Pilot Duty
13-14 / 23-24	NO	3A/240Vac Res	--
Signalling Outputs (SIGNAL)			
Output Terminals	Contacts Type	Nom. Ratings	
Nom. Ratings	Nom. Ratings	3A/30Vdc	
Environmental Ratings Max. Surrounding Air Temperature: 55°C Pollution Degree: 2 Environmental designation Open type equipment		Installation Notes Use with 60/75°C copper (CU) conductor only Terminal tightening torque: 4.5 lbIn (0,51 Nm) <u>WARNING:</u> A listed (JDYX) fuse of 250mA, non time delay shall be installed on the input terminals in the end-use application.	

ORDER CODES

Codes	Function
NC8000000000	synchronization time ts=1.8s
NC8000000320	synchronization time ts=3.2s
NC8200000000	synchronization time ts=1.8s immunity to voltage dip
NC8200000320	synchronization time ts=3.2s immunity to voltage dip