



LIMITADOR DE VELOCIDAD/
OVERSPEED GOVERNOR/
LIMITEUR DE VITESSE/
GESCHWINDIGKEITSBEGRENZER/

LBD-300

INSTRUCCIONES DE USO Y MANUTENCIÓN/
INSTRUCTIONS FOR USE AND MAINTENANCE/
INSTRUCTIONS D'USAGE ET ENTRETIEN/
GEBRAUCHS- UND WARTUNGSANLEITUNG/

CERTIFICADO DE EXAMEN C.E. DE TIPO EC TYPE-EXAMINATION CERTIFICATE

Según el anexo V parte A de la Directiva 95/16/CE / According annex V part A of Directive 95/16/EC

Número de certificado. / Certificate number	ATI / LD-VA / M139 A-1 / 05
Organismo Notificado. Notified Body	Asistencia Técnica Industrial S.A.E. (ATISAE) Avda. de la Industria, 51 bis E 28760 Tres Cantos MADRID (ESPAÑA) Nº de identificación 0053.
Clase. Tipo. Product. Type	Limitador de velocidad / Overspeed governor
Modelo / Model	LBD-300
Fabricante. Manufacturer	DYNATECH, DYNAMICS & TECHNOLOGY S.L. P. I. Pina del Ebro, sector C, parcela 9 50750 ZARAGOZA (ESPAÑA).
Propietario del certificado. Certificate Owner	DYNATECH, DYNAMICS & TECHNOLOGY S.L. P. I. Pina del Ebro, sector C, parcela 9 50750 ZARAGOZA (ESPAÑA).
Fecha de presentación. Date of submission	25/10/2005
Fecha del examen de tipo./ Date of EC type examination.	11/12/2005
Laboratorio de ensayo. Test laboratory	LABORATORIO DE ENSAYO DE MATERIALES. E.T.S. Ingenieros Industriales. UPM C/José Gutiérrez Abascal, 2 28006 MADRID (ESPAÑA)
Informe de ensayo / Test report	2002-031/3-DE MAYO DE 2004. 2005-007 (28/06/2005)
Directiva CE aplicada. / EC- Directive.	Directiva 95/16/CE de 29 de Junio de 1995
Norma de referencia. / Reference standard	EN 81-1/2:1998
Informe de ATISAE. / ATISAE report	MD_DEU_060100

Declaración: El componente de seguridad permite al ascensor sobre el que se instale satisfacer los Requisitos de Seguridad y Salud de la citada Directiva usándose dentro del alcance que queda establecido en el anexo técnico de este certificado, así como con las condiciones de instalación indicadas.

Statement: The safety component allows the lift on which installed to satisfy the requirements of health and safety of Lifts Directive when used among the scope which is established in the technical annex to this certificate, as well as under the shown installation conditions.



Bruno Cano Hernández
Coordinador Técnico

Tres Cantos, a 12 de DICIEMBRE de 2005

Este certificado consta de esta portada, un anexo técnico de 2 hojas y 1 plano / documento. Su reproducción carece de validez si no se realiza totalmente
This certificate consists of this main page, a technical annex with 2 pages and 1 drawing./document. It shall be reproduced with all its pages to be considered valid.

INSTRUCTIONS FOR USE AND MAINTENANCE

1	GENERAL INSTRUCTIONS	2
2	OVERSPEED GOVERNOR IDENTIFICATION	2
3	MAIN COMPONENTS	2
4	WORKING PRICIPLES	3
4.1	OVERSPEED CONTACT	5
4.2	HARDENED GROOVE	6
4.3	ONE WAY LBD-300 OVERSPEED GOVERNOR	6
5	FIXING TO THE FLOOR	6
6	TECHNICAL FEATURES	7
7	TYPE OF ADJUSTMENT	8
8	INSTRUCTIONS FOR USE AND MAINTENANCE	8
9	OPTIONAL DEVICES FOR LBD-300	8
9.1	PROTECTION PLATE	8
9.2	REMOTE TRIPPING MECHANISM.....	8
9.3	FINAL LIMIT DEVICE	8
9.4	REMOTE RESET DEVICE	9
9.5	PROTECTION ROPE SYSTEM.....	9
10	UCM UNCONTROLLED MOVEMENT DEVICE	9
10.2	UCM WARNINGS.....	9
11	INSTALLATION DRAWINGS	10

1 GENERAL INSTRUCTIONS

The DYNATECH LBD-300 overspeed governor is designed to cut off the current to the security series line in the event of car overspeed, bringing the lift to a standstill when necessary.

The LBD-300 overspeed governor covers a wide range of speeds and can be used with instant and progressive safety gears.

It can also include several additional systems to increase the reliability and safety of the remaining lift installation.

It is strictly forbidden:

- a) To modify or replace the overspeed governor adjustment spring.
- b) Use an overspeed governor in a lift for which it is not intended, or whose features do not correspond to those marked on the lift (e.g. nominal speed or rope type).
- c) To adjust any component of the overspeed governor, except for those parts specified in the manual.

DYNATECH DYNAMICS & TECHNOLOGY, SL will not be liable for any damage caused by failure to observe any of these general conditions.

2 OVERSPEED GOVERNOR IDENTIFICATION

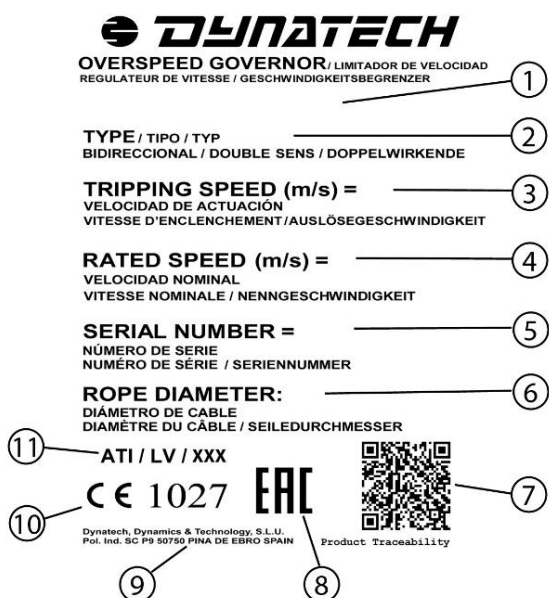

OVERSPEED GOVERNOR IDENTIFICATION STICKER			
1	Governor model	7	QR product traceability code
2	Governor type	8	Marking for market access to member states of the Customs Union
3	Performance speed (m/s)	9	Dynatech address
4	Rated speed (m/s)	10	Quality assurance CE marking and notified body number
5	Serial number	11	EU type examination certificate number
6	Rope diameter (mm)		

3 MAIN COMPONENTS

Each governor is composed of the following main elements: a pulley, a centrifugal system, a locking device, a casing and a plate linking the governor to the floor in the machine room.

Below is an image of the governor assembly:

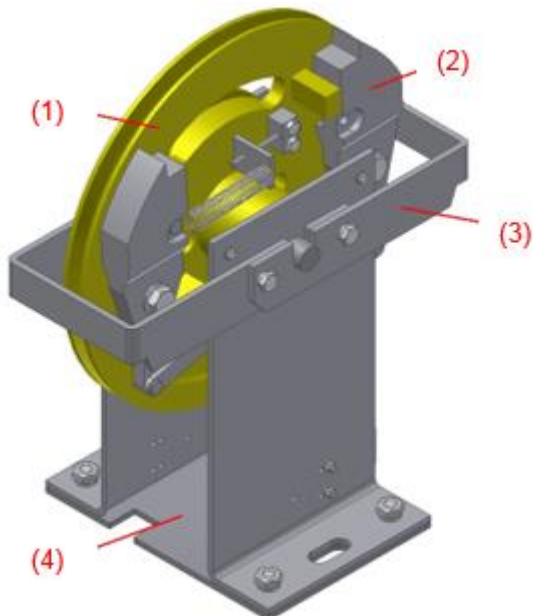

Where:

- (1) Main Pulley.
- (2) Centrifugal system.
- (3) Locking system.
- (4) Floor fixing plate

Figure 1: LBD-300 Components

4 WORKING PRICIPLES

The governor is of the centrifugal type and is able to work either upwards or downwards.

The governor is fixed directly to the floor in the machine room, joined by the rope to its tensing pulley located in the pit.

This tensing pulley is attached to the guide pulley by flanges.

The rope passes through the groove of governor and the tensing pulley.

The ends of the rope are attached to the linkage anchoring. Thus, when the car reaches its tripping speed, the rope-governor relative movement will lock it.

The working diagram is as allow:

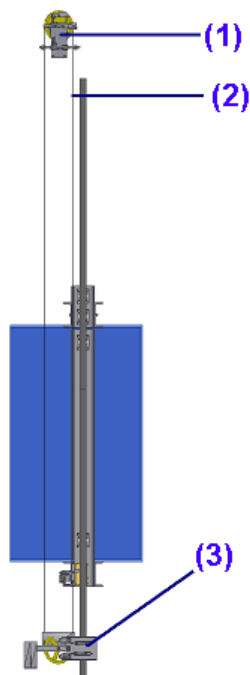

- (1) Governor LBD-300
- (2) Governor rope
- (3) Tension weight

Figure 2: Working diagram

As indicated above, the governor is secured to the floor in the machine room.

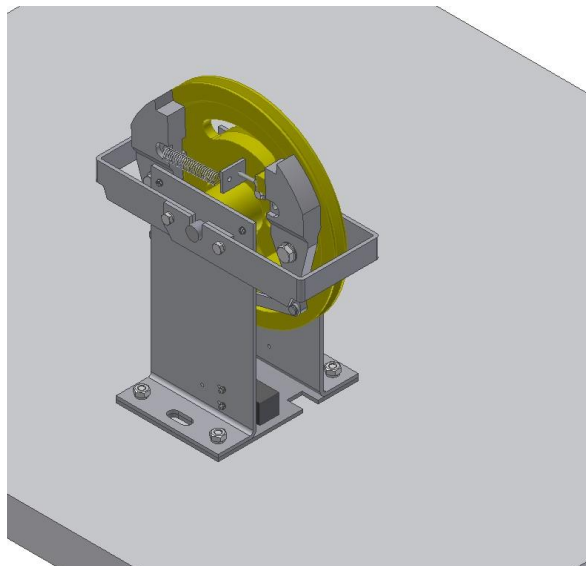

Figure 3: Governor Linkage to floor

The ends of the rope (2) are attached to the linkage anchoring (1) through eyes.

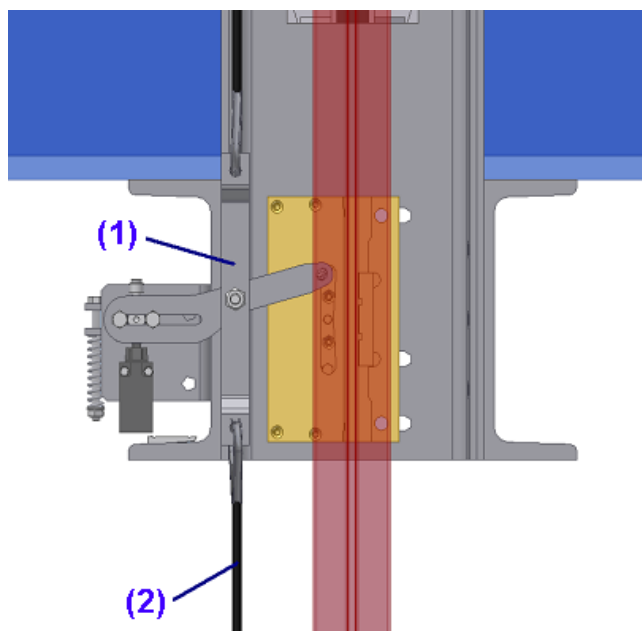

Figure 4: Rope's linkage

The tension weight is secured to the guide rail by flanges.

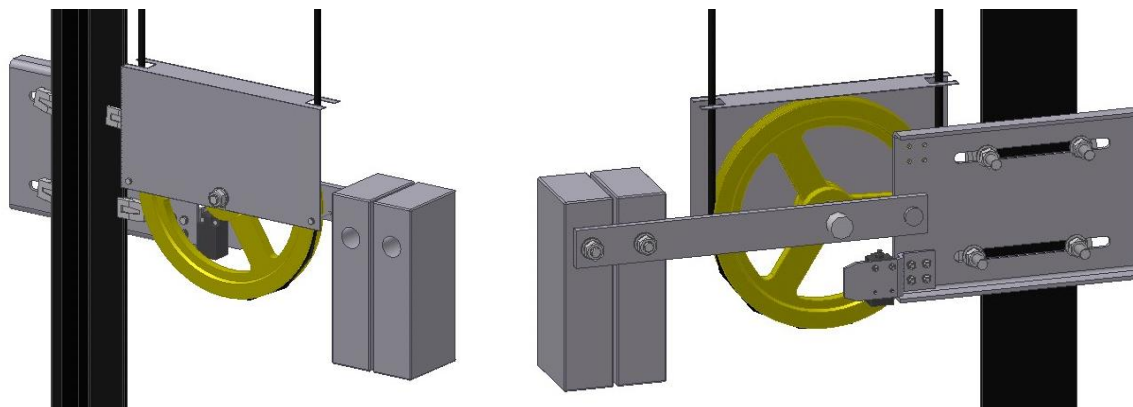
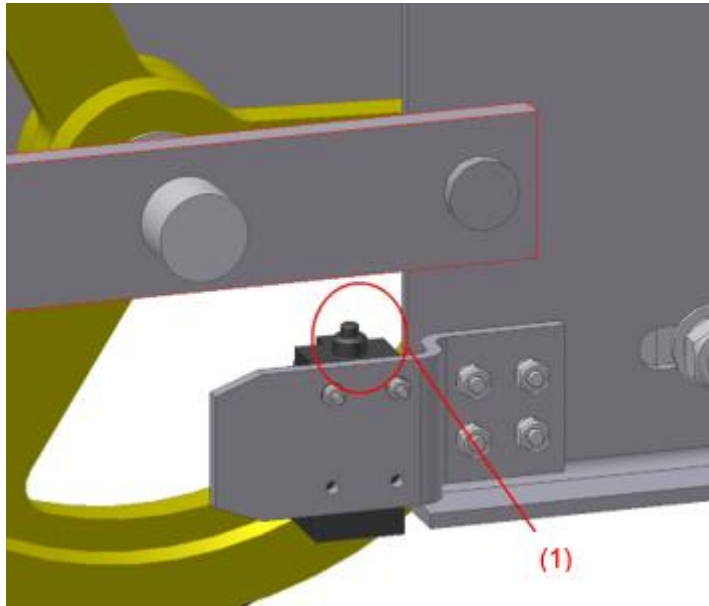

Figure 5: Securing of tension pulley

The rope must have enough tension (500 N on each side). In the event of tension loosening or rope breakage, a rope slackening contact (1) connected to the installation security series line will cut off the current.



In the event of the tension loosening or even the rope breaking, the current would be cut thanks to the contact located underneath the weight-bearing bar.

Due to the weight of the masses, the contact is protected from knocks by the part to which it is attached and, therefore, the sensor cannot be damaged.

The tension weight assembly can be attached to both sides of the guide pulley. The guide rail fixing plate has holes on both sides so that the contact is not a problem when changing the position of the assembly and so that the sensor can be attached on both sides.

4.1 OVERSPEED CONTACT

The governor has a built-in overspeed contact.

Below is a drawing of the overspeed contact location (1) on the governor.

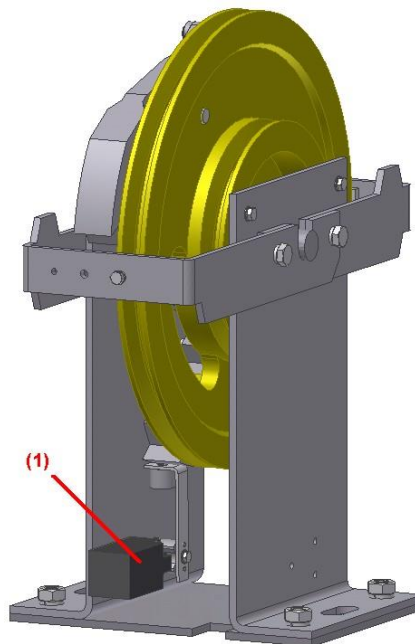

Figure 9: Overspeed contact

The contact will act when the governor reaches a speed above the rated speed yet below the speed at which the governor is enabled.

When this contact is triggered, the current of the security series line is cut off.

This system is manually reset, which means that once the contact has been triggered it does not return to its initial position unless this is done manually.

4.2 HARDENED GROOVE

It is possible to order the governor with a hardened groove. The following data is provided to assess whether or not ordering the governor with this option is required.

Non-hardened groove: 500000 cycles

Hardened groove: 1500000 cycles

Note: This data is the result of tests performed on Dynatech premises and are for illustrative purposes only. The wear depends on the type of installation, traffic, tension on the governor rope, speed, etc.

The client must decide whether or not to select this option depending on the type of installation.

4.3 ONE WAY LBD-300 OVERSPEED GOVERNOR

The LBD-300 overspeed governor may be sent for any speed as a one-way overspeed governor.

Attention must be paid to the direction of rotation of the overspeed governor when it is one-way.

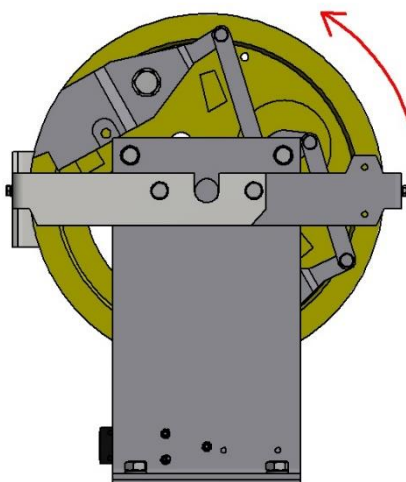

5 FIXING TO THE FLOOR

The figure shows the governor anchoring points to the lift floor. Distances appear in millimeters.

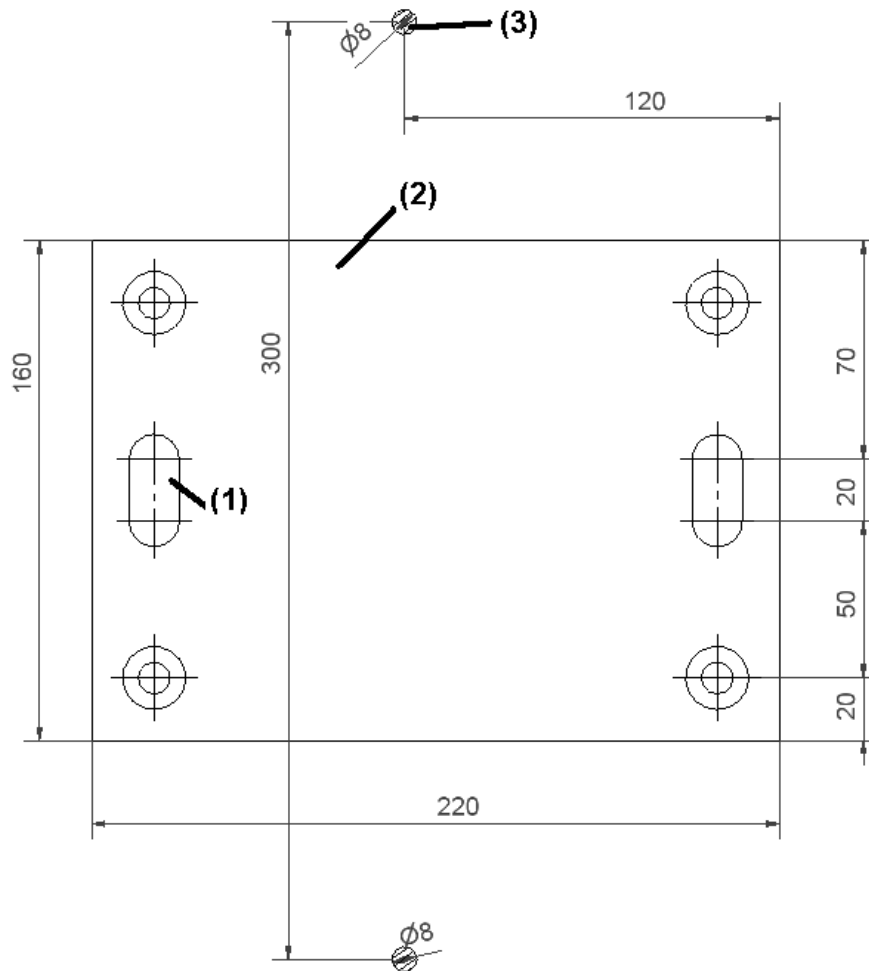

Figure 10: Governor anchoring points

The above figure represents the bottom view of the governor base plate (2). The governor is anchored to the floor using the threaded holes (1) in the plate. The rope (3) and its position with regard to the base plate can also be seen in the drawing.

6 TECHNICAL FEATURES

- **Machine:** Overspeed governor
- **Model:** LBD-300
- **Manufacturing company:**
 - o DYNATECH, DYNAMICS & TECHNOLOGY, S.L.
- **Range of use:**
 - o Minimum rated speed: 0.1 m/s
 - o Minimum tripping speed: 0.9 m/s
 - o Maximum rated speed: 1.5 m/s
 - o Maximum tripping speed: 2 m/s
- **Rope:**
 - o Diameter: 8 mm
 - o Diameter: 6 mm
 - o Composition: 6 x 19 + 1

- **Rope pre-tightness:**
 - o 500 N
 - o This tightness is achieved by positioning the tension weight so that the bar is horizontal.
- **Tightness produced on the rope during interlocking:**
 - o Greater than 300 N
- **Pulley diameter:** 300 mm
- **Overspeed contact.**
- **Anticreep device to fulfil the A3 ammendment:**
 - o The using of the D-box is recommended with the anticreep device
- **Safety gears with which it may be used:**
 - o All safety gears with a tripping speed that can be reached by the overspeed governor.

7 TYPE OF ADJUSTMENT

This adjustment is carried out in the factory using a computerized gauging system according to the customer's specifications. Once the adjustment has been made and checked, it is sealed so that it cannot be modified.

8 INSTRUCTIONS FOR USE AND MAINTENANCE

The tripping speed on the installation can be checked either on the motor frequency changer by progressively increasing the motor speed until interlocking is obtained or on the check pulley.

To avoid unnecessary risks that may cause the governor to operate incorrectly, two basic criteria must be taken into account: cleaning and checking for corrosion. There are moving parts in any governor that carry out the interlocking actions. The accumulation of dirt on these parts may cause malfunctioning. The installer and the maintenance staff must ensure that these parts are perfectly clean.

Moreover, all Dynatech governors have rustproof protection, although it is important for maintenance staff to check for any corrosion that may affect any moving piece of the part and prevent its natural movement. This check will be carried out by visually inspecting the surface condition and by making the parts move. The frequency of these checks is at the discretion of the maintenance staff, although they should be more frequent in the event of the installation being in a particularly corrosive environment.

Dynatech will not be held responsible for any problem or accident caused by not observing the indications and advice described both in these instructions and in the EC Type examination certificates.

9 OPTIONAL DEVICES FOR LBD-300

9.1 PROTECTION PLATE

As it is indicated in the 9.7.1 section of the UNE-EN 81 standard, the overspeed governor must be with a protection in order to avoid corporal damages and the entrance of foreign objects.

9.2 REMOTE TRIPPING MECHANISM

In the overspeed governor it is able to be incorporated a mechanic system that interferes in the centrifugal masses, causing an acting of the overspeed governor. This system consists of a solenoid that is available on 24, 48 or 190 V, which currents are 1.1, 0.7 and 0.2 A respectively.

Also there is an option of acting the system without the solenoid.

9.3 FINAL LIMIT DEVICE

A Final Limit device can be assembled in the overspeed governor support.

It will be provided a stops which make contact with the levers. This levers will act the security contact switch.

9.4 REMOTE RESET DEVICE

Another option for the overspeed governor LBD-300 is to reset automatically the overspeed contact. It is used a solenoid available in 24, 48 or 190 V with currents of 1.1, 0.7 and 0.2 A respectively.

9.5 PROTECTION ROPE SYSTEM.

This option exists In order to avoid the entrance of foreign objects in the gaps where ropes of the overspeed governor go through. This device is shown in the figure. The overspeed is mounted on the plate of the system.

The ensemble it is placed in the floor by means of some holes in the plate.

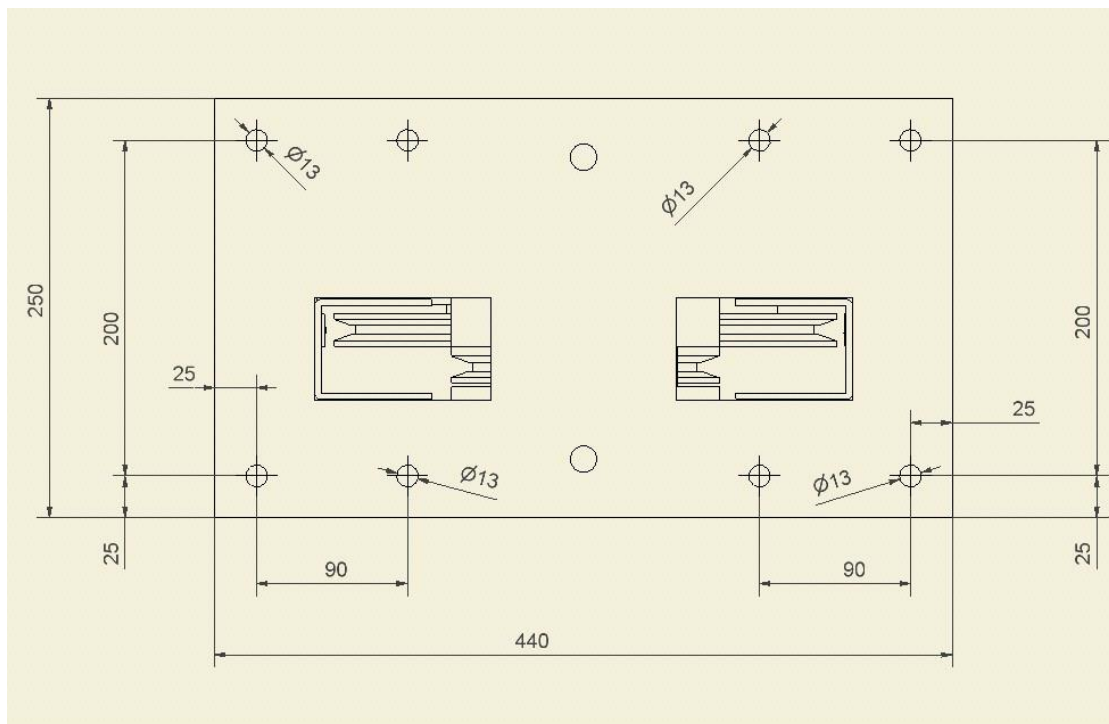

Figure 19: Base of the anchoring plate

The overspeed governor can be provided with all the option mentioned previously. However the customer can order the overspeed with the options that fit better to their needs. In the orders it must be indicated what kind of options the customer wish.

10 UCM UNCONTROLLED MOVEMENT DEVICE

10.2 UCM WARNINGS.

The anti-creep system requires the lift controller to be able to manage the functions that the anti-creep system uses, such as the coil power, control sensor monitoring and manual rescue. If the controller is unable to manage these functions, Dynatech offers the possibility of installing an electronic module, D-Box. For more information, see the website.

If the D-Box is not used, please observe the following warnings and follow the recommendations below for proper controller design.

Note. It is highly recommended that the controller designer contacts Dynatech before designing the circuit to manage the anti-creep system, to clarify any doubts regarding connections and to be recommended a specific solution for their installation.

- Locking the overspeed governor after UCM can be done by either of the following 2 methods: 1) Detecting the UCM or 2) Letting the anti-creep system act.
 - 1) To detect the UCM, either a sensor needs to be placed on each floor or, as is the case with the D-Box, a levelling signal needs to be used. Therefore, if the car creeps with the doors open, the sensor detects it and cuts off the current to the anti-creep system coil, thus locking the overspeed governor.

2) In this case, the anti-creep system clamping device is locked at each floor in the installation. When the lift moves, the anti-creep system coil is excited and releases the overspeed governor. Then, once the car reaches one of the floors, the current to the coil is cut, leaving the anti-creep system in the locked position. The D-Box has a feature whereby, when the elevator reaches a floor, current continues through the coil for a set time, usually 10 minutes, if the lift does not receive another call. After this time, the anti-creep system locking device is activated. This correction is due to the VDI 4707 Part 1 (German lift energy efficiency standard) which establishes a period of 5 minutes before stand-by. Thus, the anti-creep system performs fewer on-off cycles, thereby increasing its useful life. This is helpful in periods when there is heavy traffic, as it prevents the anti-creep system from repeatedly locking and unlocking the overspeed governor. It must be remembered that a UCM sensor will need to be installed if the anti-creep system works this way.

- **It is recommended to over-excite the coil** with a voltage slightly above nominal for less than one second to ensure the anti-creep system unlocks. Once it is unlocked and the lift begins to move, the supply voltage should be reduced during the journey to lessen the coil heating.

Also, if the choice of keeping the coil excited while the lift is at a floor is taken, the voltage to the solenoid can also be lowered. This saves energy and improves the energy efficiency of the lift.

Below is a table of recommended voltages.

All values - V	Over-excitation	Voltage during travel	Voltage at floor
24	30	20	12
48	60	40	30
190	215-205*	150	104

* This is the voltage at the rectifier output, which can vary between the values shown.

- To ensure proper operation of the device, it is advisable to design a circuit such that, if the inductive sensor does not detect the anti-creep system unlocking, the controller will **try more than once to supply current to the coil** (the Dynatech D-Box makes 7 attempts before the error message appears that no reading for the control sensor is detected).

Thus, if there is any mechanical fault preventing the sensor from being read, the same attempts to solve the problem will be made before an error message appears on the controller.

- To prevent the car from stopping due to the loss of the control sensor signal while travelling, it makes a reading only at the floors.
- **In the event of a cut in the electricity supply** to the electric magnet coil when the car is moving, the speed governor will lock and the safety gear subsequently engaged. The installation of an autonomous power system is recommended to avoid undesired engagement in the event of a cut in the mains electricity supply.
- Open the pin to enable the speed governor to turn for automatic rescue. If the pin is not released, the governor will lock and the safety gear will engage during the rescue movement.
- Use in **installations with re-levelling over 20 mm**: in installations with re-levelling over 20 mm, certified switching must be used to activate the electric magnet during the re-levelling process because if it re-levels by more than 20 mm then the governor could lock and the safety gear engage. In this case, the switching must discriminate between re-levelling and an uncontrolled movement.
- Use in **installations with door pre-opening**: in installations with door pre-opening, certified switching must be used to ensure the electric magnet remains activated during the pre-opening process because if the electric magnet does not remain activated then the governor could lock and the safety gear engage. In this case, the switching must discriminate between pre-opening and an uncontrolled movement.

11 INSTALLATION DRAWINGS

Please find below the following governor's drawings:

- DYN 19.C01.00
- DYN 19.C02.00

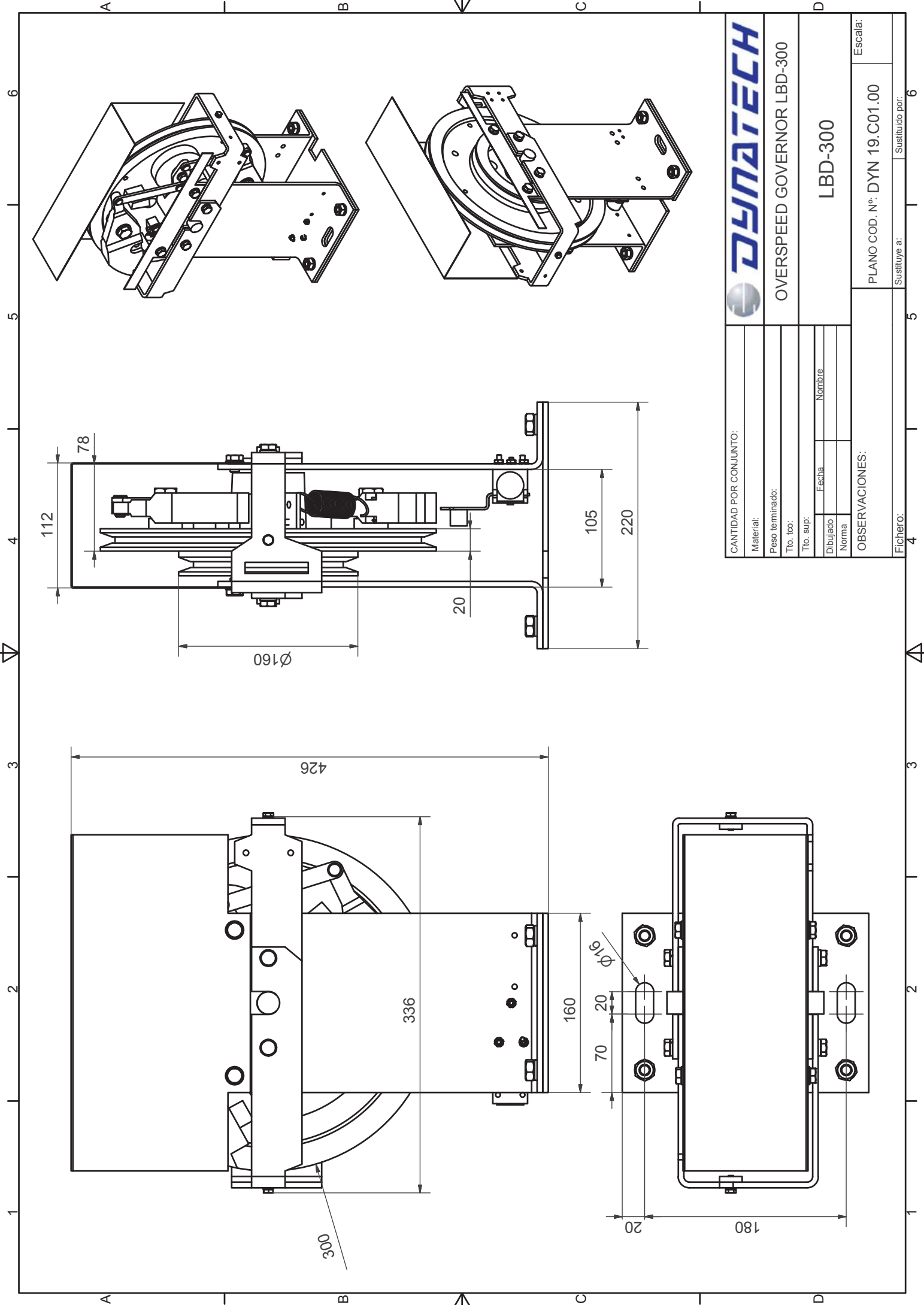

CANTIDAD POR CONJUNTO:		DYNATECH	
Material:		OVERSPEED GOVERNOR LBD-300	
Peso terminado:		LBD-300	
Tto. tco:		PLANO COD. N°: DYN 19.C01.00	
Tto. sup:		Escala:	
Dibujado	Fecha	Nombre	
Norma	OBSERVACIONES:		
Fichero:	Sustituye a:	Sustituido por:	

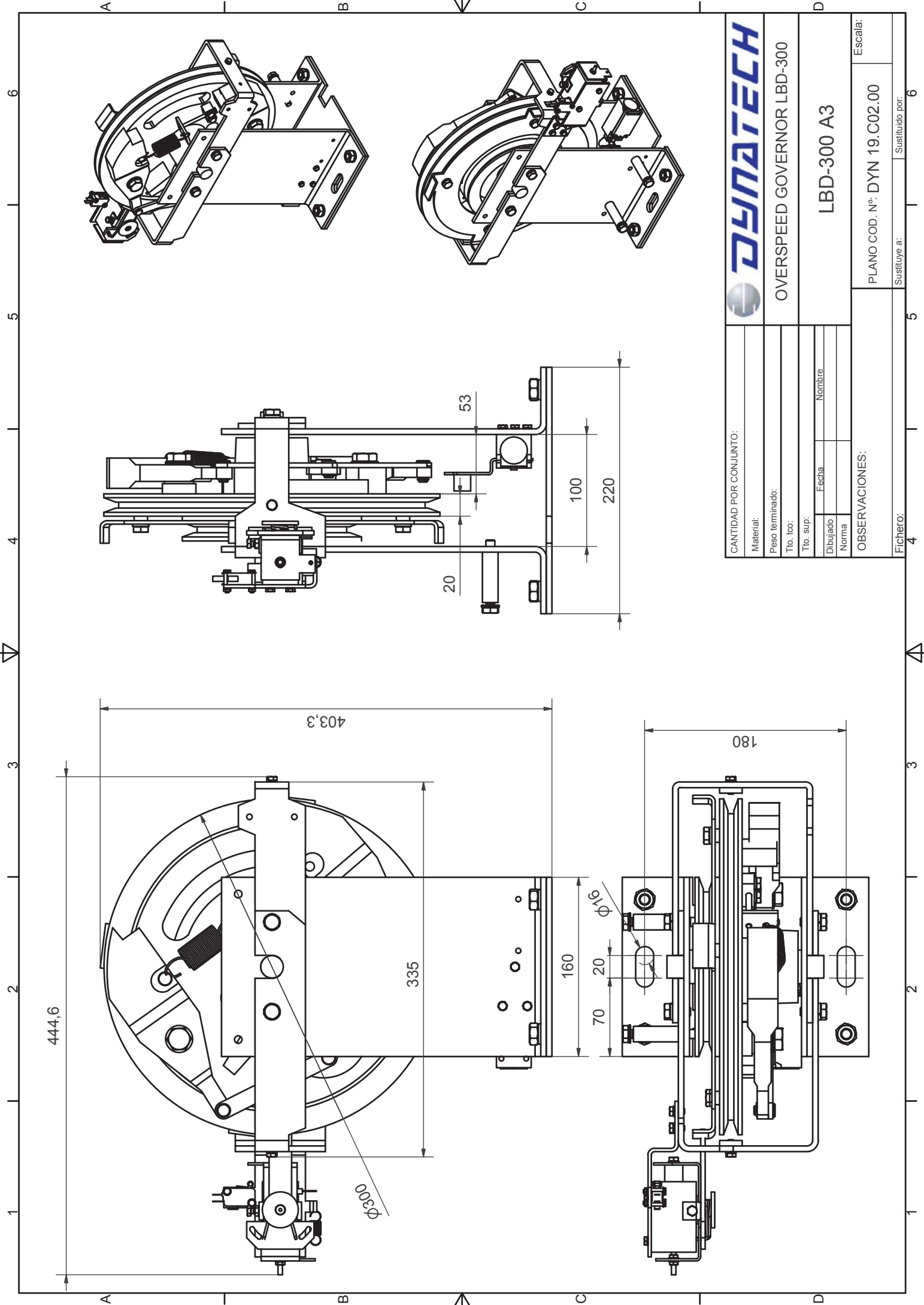

CANTIDAD POR CONJUNTO:		DYNATECH	
Material:		OVERSPEED GOVERNOR LBD-300	
Peso terminado:		LBD-300 A3	
Tto. tco:		PLANO COD. N°: DYN 19.C02.00	
Tto. sup:		Escala:	
Dibujado	Fecha	Sustituye a:	
Nombre		Fichero:	
Norma		Sustituido por:	
OBSERVACIONES:		4	
		5	
		6	