



LIMITADOR DE VELOCIDAD/  
OVERSPEED GOVERNOR/  
LIMITEUR DE VITESSE/  
GESCHWINDIGKEITSBEGRENZER/

**LBD-200**

INSTRUCCIONES DE USO Y MANUTENCIÓN/  
INSTRUCTIONS FOR USE AND MAINTENANCE/  
INSTRUCTIONS D'USAGE ET ENTRETIEN/  
GEBRAUCHS- UND WARTUNGSANLEITUNG/

## CERTIFICADO DE EXAMEN C.E. DE TIPO EC TYPE-EXAMINATION CERTIFICATE

Según el anexo V parte A de la Directiva 95/16/CE / According annex V part A of Directive 95/16/EC

Número de certificado. / Certificate number	ATI / LD-VA / M145A-1 / 08
Organismo Notificado. Notified Body	Asistencia Técnica Industrial S.A.E. (ATISAE) Avda. de la Industria, 51 bis E 28760 Tres Cantos MADRID (ESPAÑA) Nº de identificación 0053.
Clase. Tipo. Product. Type	Limitador de velocidad / Overspeed governor
Modelo / Model	LBD-200
Fabricante. Manufacturer	DYNATECH, DYNAMICS & TECHNOLOGY S.L. P.I. Pina del Ebro, sector C, parcela 9 50750 ZARAGOZA ( ESPAÑA ).
Propietario del certificado. Certificate Owner	Véase fabricante / Please refer to manufacturer
Fecha de presentación. Date of submission	26/03/2008
Fecha del examen de tipo. Date of EC type examination.	02/04/2008
Laboratorio de ensayo. Test laboratory	(véase en el anexo técnico sección 2.8). (Please refer to technical annex section 2.8)
Informe de ensayo / Test report	(véase en el anexo técnico sección 2.8). (Please refer to technical annex section 2.8)
Directiva CE aplicada. / EC- Directive.	Directiva 95/16/CE de 29 de Junio de 1995
Norma de referencia. / Reference standard	EN 81-1/2:1998
Informe de ATISAE. / ATISAE report	MD_DEU_081180 (01.04.2008) ED_051783 (19.04.2005)
Plazo de validez / Expiry date	Indefinido / (véase en el anexo técnico sección 2.10). Indefinite / (Please refer to technical annex section 2.10)

### Declaración:

El componente de seguridad permite al ascensor sobre el que se instale satisfacer los Requisitos de Seguridad y Salud de la citada Directiva usándose dentro del alcance que queda establecido en el anexo técnico de este certificado, así como con las condiciones de instalación indicadas.

### Statement:

The safety component allows the lift on which installed to satisfy the requirements of health and safety of Lifts Directive when used among the scope which is established in the technical annex to this certificate, as well as under the shown installation conditions.

Tres Cantos, a 02 de ABRIL de 2008

  
\*José Manuel Flórez González  
Coordinador Técnico

Este certificado consta de esta portada, un anexo técnico de 2 hojas y 1 plano / documento. Su reproducción carece de validez si no se realiza totalmente.  
This certificate consists of this main page, a technical annex with 2 pages and 1 drawing./document. It shall be reproduced with all its pages to be considered valid.

## INSTRUCTIONS FOR USE AND MAINTENANCE

---

<b>1</b>	<b>GENERAL INSTRUCTIONS .....</b>	<b>2</b>
<b>2</b>	<b>OVERSPEED GOVERNOR IDENTIFICATION .....</b>	<b>2</b>
<b>3</b>	<b>MAIN COMPONENTS.....</b>	<b>2</b>
<b>4</b>	<b>OPERATING PRINCIPLES.....</b>	<b>3</b>
4.1	OVERSPEED CONTACT.....	4
4.2	HARDENED GROOVE .....	5
4.3	ONE-WAY LBD-200 OVERSPEED GOVERNOR.....	5
<b>5</b>	<b>FIXING TO THE FLOOR.....</b>	<b>6</b>
<b>6</b>	<b>TECHNICAL CHARACTERISTICS.....</b>	<b>6</b>
<b>8</b>	<b>USER AND MAINTENANCE INSTRUCTIONS.....</b>	<b>7</b>
8.1	STORAGE AND SERVICE LIFE .....	7
<b>9</b>	<b>OPTIONAL DEVICES FOR LBD-200.....</b>	<b>8</b>
9.1	PROTECTION PLATE:.....	8
9.2	REMOTE TRIPPING MECHANISM .....	8
9.3	FINAL LIMIT DEVICE .....	8
9.4	REMOTE RESET DEVICE .....	8
<b>10</b>	<b>INSTALLATION DRAWINGS.....</b>	<b>8</b>

---

# 1 GENERAL INSTRUCTIONS

The DYNATECH LBD-200 overspeed governor is designed to cut off the current to the security series line in the event of car overspeed, bringing the lift to a standstill when necessary.

The LBD-200 overspeed governor covers a wide range of speeds and can be used with instant and progressive safety gears.

It can also include several additional systems to increase the reliability and safety of the remaining lift installation.

It is strictly forbidden:

- a) To modify or replace the overspeed governor adjustment spring.
- b) Use an overspeed governor in a lift for which it is not intended, or whose features do not correspond to those marked on the lift (e.g. nominal speed or rope type).
- c) To adjust any component of the overspeed governor, except for those parts specified in the manual.

DYNATECH DYNAMICS & TECHNOLOGY, SL will not be liable for any damage caused by failure to observe any of these general conditions.

# 2 OVERSPEED GOVERNOR IDENTIFICATION

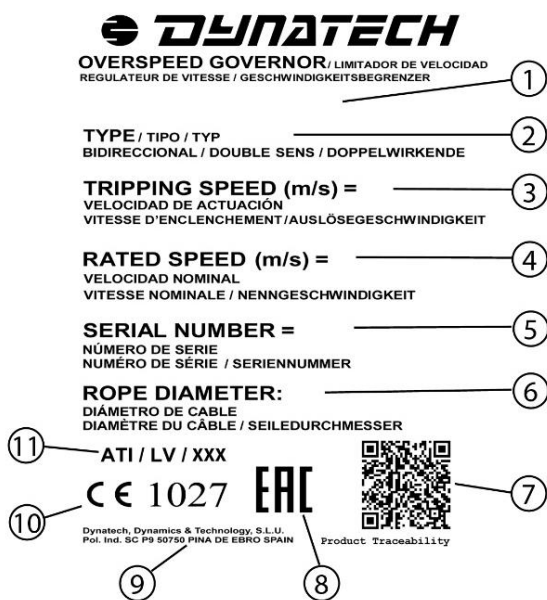

GOVERNOR IDENTIFICATION STICKER			
1	Governor model	7	QR product traceability code
2	Governor type	8	Marking for market access to member states of the Customs Union
3	Performance speed (m/s)	9	Dynatech address
4	Rated speed (m/s)	10	Quality assurance CE marking and notified body number
5	Serial number	11	EU type examination certificate number
6	Rope diameter (mm)		

# 3 MAIN COMPONENTS.

Each governor is composed of the following main elements: a pulley, a centrifugal system, a locking device, a casing and a plate linking the governor to the floor in the machine room.

Below is an image of the governor assembly:

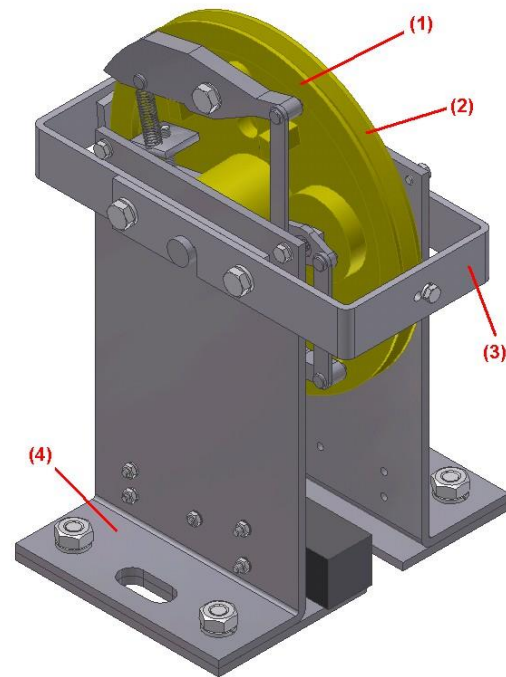

Where:

- (1) Main pulley.
- (2) Centrifugal system.
- (3) Locking system.
- (4) Floor fixing plate

## 4 OPERATING PRINCIPLES.

The governor is of the centrifugal type and is able to work either **upwards** or **downwards**.

The governor is fixed directly to the floor in the machine room, joined by the rope to its tensing pulley located in the pit.

This tensing pulley is attached to the guide pulley by flanges.

The rope passes through the groove of governor and the tensing pulley.

The ends of the rope are attached to the linkage anchoring. Thus, when the car reaches its tripping speed, the rope-governor relative movement will lock it.

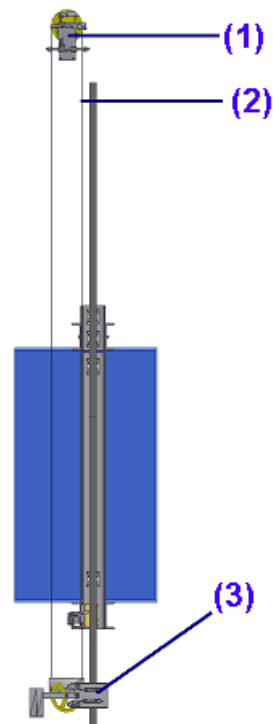

The working diagram is as follows:

- (1) LBD-200 governor
- (2) Governor rope
- (3) Tensing pulley

As indicated above, the overspeed governor is attached to the floor in the machine room or in the lift well.

The ends of the rope (2) are attached to the linkage anchoring (1) through eyes.

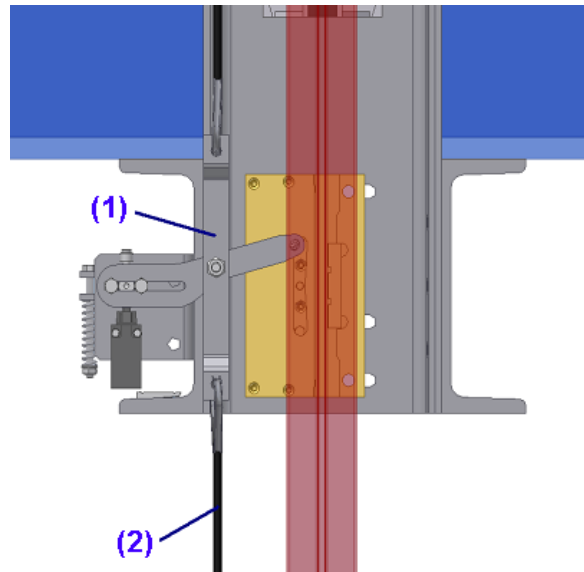

The tensing pulley is secured to the guide rail by flanges.

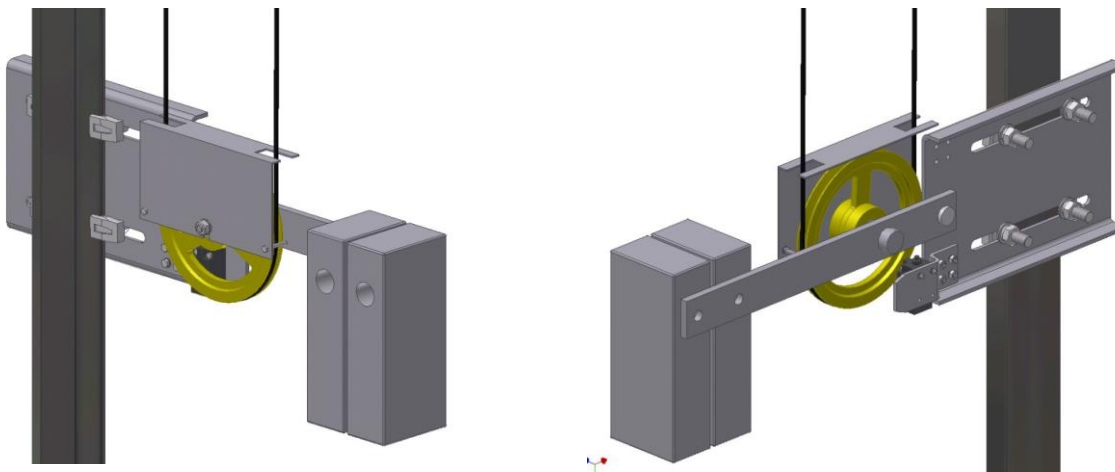

The rope must have enough tension (500 N on each side). In the event of tension loosening or rope breakage, a rope slackening contact (1) connected to the installation security series line will cut off the current.

Due to the weight of the masses, the contact is protected from knocks by the part to which it is attached and, therefore, the sensor cannot be damaged.

The tensing pulley assembly can be attached to both sides of the guide pulley. The guide rail fixing plate has holes on both sides so that the contact is not a problem when changing the position of the assembly and so that the sensor can be attached on both sides.

As indicated, should the tightness be less than acceptable or should the rope break, the bar supporting the weight and the pulley would make contact with the sensor.

#### 4.1 OVERSPEED CONTACT.

The governor has a built-in overspeed contact.

Below is a drawing of the overspeed contact location (1) on the governor.

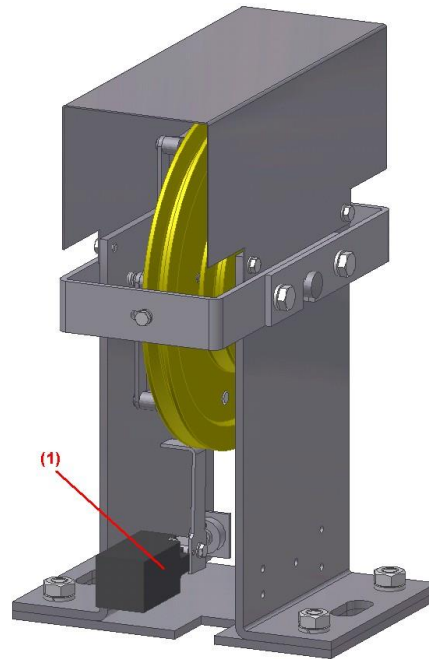

The contact will act when the governor reaches a speed above the rated speed yet below the speed at which the governor is enabled.

When this contact is triggered, the current of the security series line is cut off.

This system is manually reset, which means that once the contact has been triggered it does not return to its initial position unless this is done manually.

## 4.2 HARDENED GROOVE

It is possible to order the governor with a hardened groove. The following data is provided to assess whether or not ordering the governor with this option is required.

Non-hardened groove: 500000 cycles

Hardened groove: 1500000 cycles

**Note:** This data is the result of tests performed on Dynatech premises and are for illustrative purposes only. The wear depends on the type of installation, traffic, tension on the governor rope, speed, etc. The client must decide whether or not to select this option depending on the type of installation.

## 4.3 ONE-WAY LBD-200 OVERSPEED GOVERNOR

The LBD-200 overspeed governor may be sent for any speed as a one-way overspeed governor.

Attention must be paid to the direction of rotation of the overspeed governor when it is one-way.

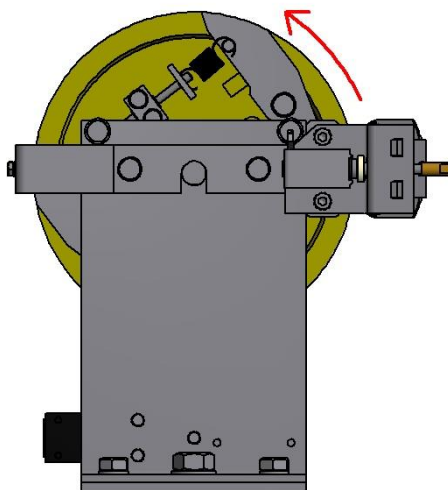

## 5 FIXING TO THE FLOOR.

The figure shows the governor anchoring points to the lift floor. Distances appear in millimetres.

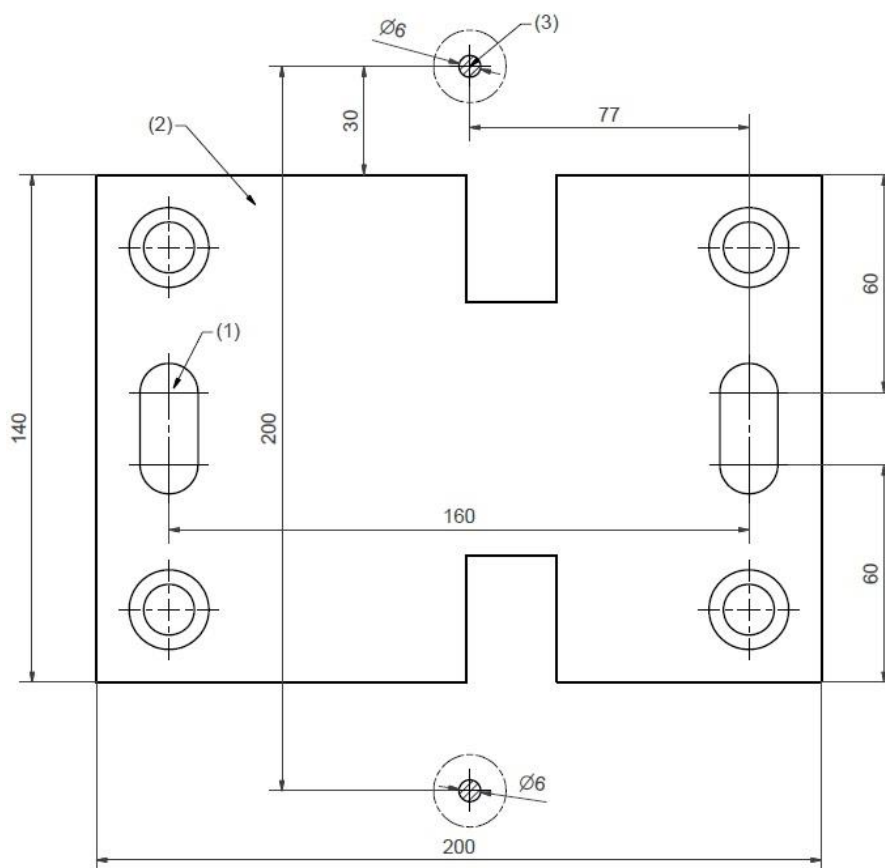

The above figure represents the bottom view of the governor base plate (2).

The governor is anchored to the floor using the threaded holes (1) in the plate.

The rope (3) and its position with regard to the base plate can also be seen in the drawing.

## 6 TECHNICAL CHARACTERISTICS.

- **Appliance:** Overspeed governor
- **Model:** LBD-200
- **Manufacturing company:**

DYNATECH, DYNAMICS & TECHNOLOGY, S.L.

- **Field of action:**

Minimum rated speed: 0.1 m/sec

Minimum tripping speed: 0.8 m/sec

Maximum rated speed: 2.3 m/sec

Maximum tripping speed: 2.74 m/sec

Note: A low-speed pulley with a special low-speed centrifugal system is used for *operating* speeds below 1m/sec.

- **Rope:**

Diameter: 6 mm, 6.3 mm y 6.5 mm

Composition: 6 x 19 + 1

- **Initial rope tightness:**

500 N

This tightness is given by positioning the tensing pulley so that the bar remains horizontal.

- **Tightness produced on the rope on locking:**

Over 300 N

- **Pulley diameter:** 200 mm

- **Overspeed contact.**

- **Other features:**

Possibility of fitting several devices:

- Remote tripping mechanism
- Remote rest
- Final Limit switch

Possibility of ordering the pulley groove hardened.

- **Safety gear with which it can be used:**

Any with a tripping speed that can be reached by the overspeed governor.

## 8 USER AND MAINTENANCE INSTRUCTIONS.

The trigger speed on the installation can be checked using the motor frequency splitter, increasing the motor speed progressively until the installation locks, or using the check pulley.

To avoid unnecessary risks that may cause the governor to operator incorrectly, take the following two basic criteria into account: Cleanliness and monitoring of rust. There are moving parts on all governors that carry out the locking action. The accumulation of dirt on these parts may lead to malfunctioning. Both the fitter and the maintenance staff must make sure that these parts are perfectly clean.

All Dynatech overspeed governors include rustproof protection, although the maintenance staff must check for rust that may affect any moving part or prevent it from moving naturally. This check will be carried out by means of a visual inspection of the surface condition and by making the parts work. These checks must be carried out as often as the maintenance staff sees fit, although they must be more frequent in the event of the lift being installed in a particularly corrosive atmosphere.

Dynatech will not be held responsible for any problem or accident arising from the lack of observance of the indications and advice given in these instructions and in the Type E.E.C. examination certificates.

### 8.1 STORAGE AND SERVICE LIFE

The overspeed governor must be stored in a cool, dry place. It must be protected from excessive light and never be exposed to the open air.

Storage temperature: 5 - 40°C.

Storage Humidity: 15 - 85% without condensation

Overspeed governor packages should be clean and dry so that they can be clearly identified.

Constantly leaning an unbalanced load on packages, which may cause bending, or the accumulation of products stacked on top of each other is not allowed. When placing products or product packages on top of each other, the storage height should correspond to the packages' load and stability.

If the established criteria of this manual are observed, the overspeed governor's service life is set by the wear of his main pulley groove, which depends on the installation duty cycle. When estimating the element's service life, the effects of grease, dust or dirt due to the shaft's condition or to environmental conditions differing from those stated in this manual, were not taken into consideration.

## **9 OPTIONAL DEVICES FOR LBD-200.**

### **9.1 PROTECTION PLATE:**

As it is indicated in the 9.7.1. Section of the UNE-EN 81 standard, the overspeed governor must be with a protection in order to avoid corporal damages and the entrance of foreign objects.

### **9.2 REMOTE TRIPPING MECHANISM**

In the overspeed governor it is able to be incorporated a mechanic system that interferes in the centrifugal masses, causing an acting of the overspeed governor. This system consists of a solenoid that is available on 24, 48 or 190 V, which currents are 1.1, 0.7 and 0.2 A respectively.

### **9.3 FINAL LIMIT DEVICE**

A Final Limit Device can be assembled in the overspeed governor support. It will be provided stops which make contact with levers. These levers will act the security contact switch.

### **9.4 REMOTE RESET DEVICE**

Another option for the overspeed governor LBD-200 is to reset automatically the overspeed contact. It is used a solenoid available in 24, 48 or 190 V with currents of 1.1, 0.7 and 0.2 A respectively.

The overspeed governor can be provided with all the options mentioned previously. However the customer can order the overspeed with the options that fit better to their needs.

In the orders it must be indicated what kind of options the customer wish.

## **10 INSTALLATION DRAWINGS.**

The following drawing may be of help when adapting and installing the LBD-200 overspeed governor.

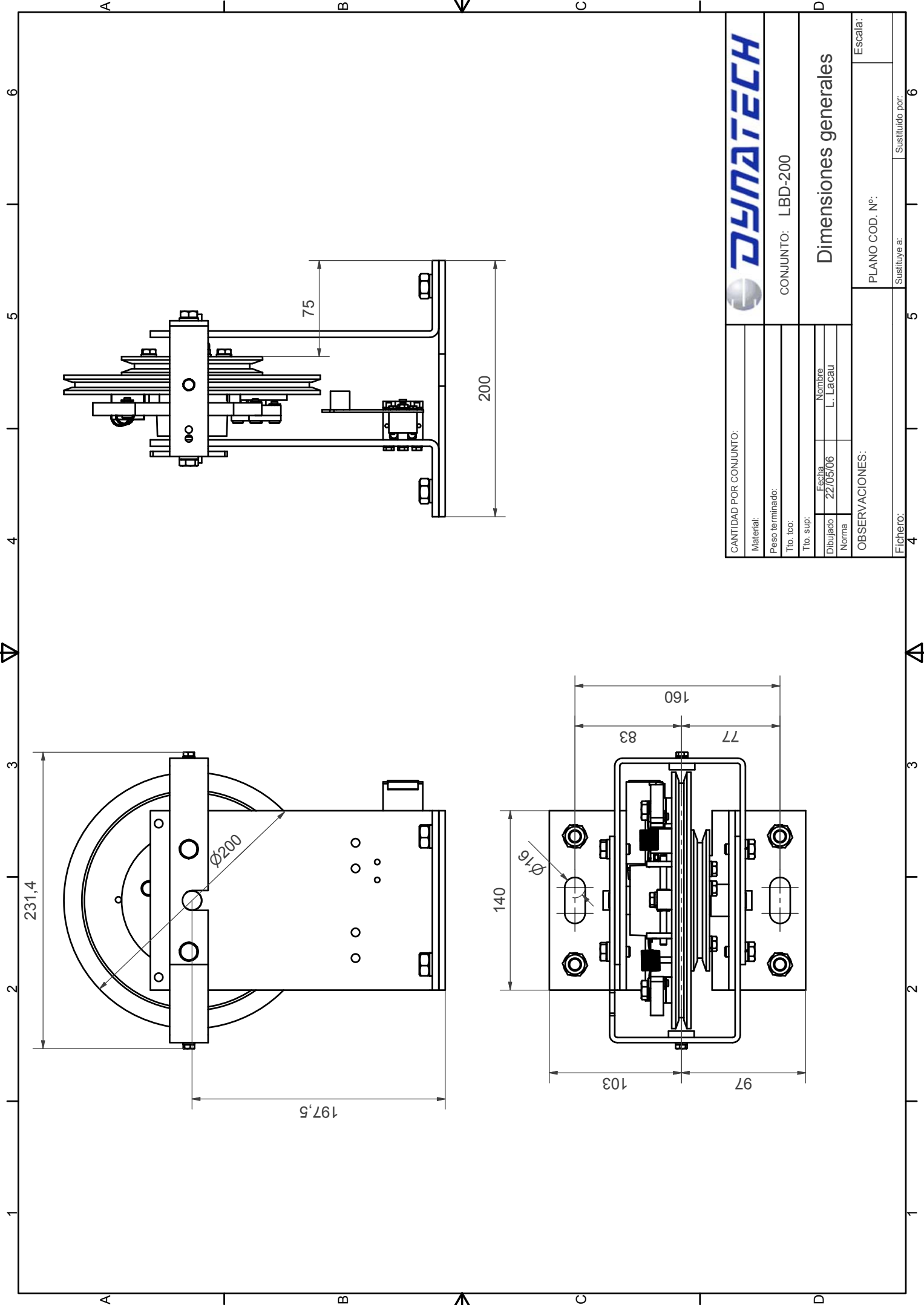

CANTIDAD POR CONJUNTO:

Material:

Peso terminado:

Tto. tco:

Tto. sup:

Dibujado

Norma

OBSERVACIONES:

Fichero:



CONJUNTO: LBD-200

Dimensiones generales

PLANO COD. N°:

Escala:

Sustituye a:

Sustituido por: