

## Installation and Startup Guide

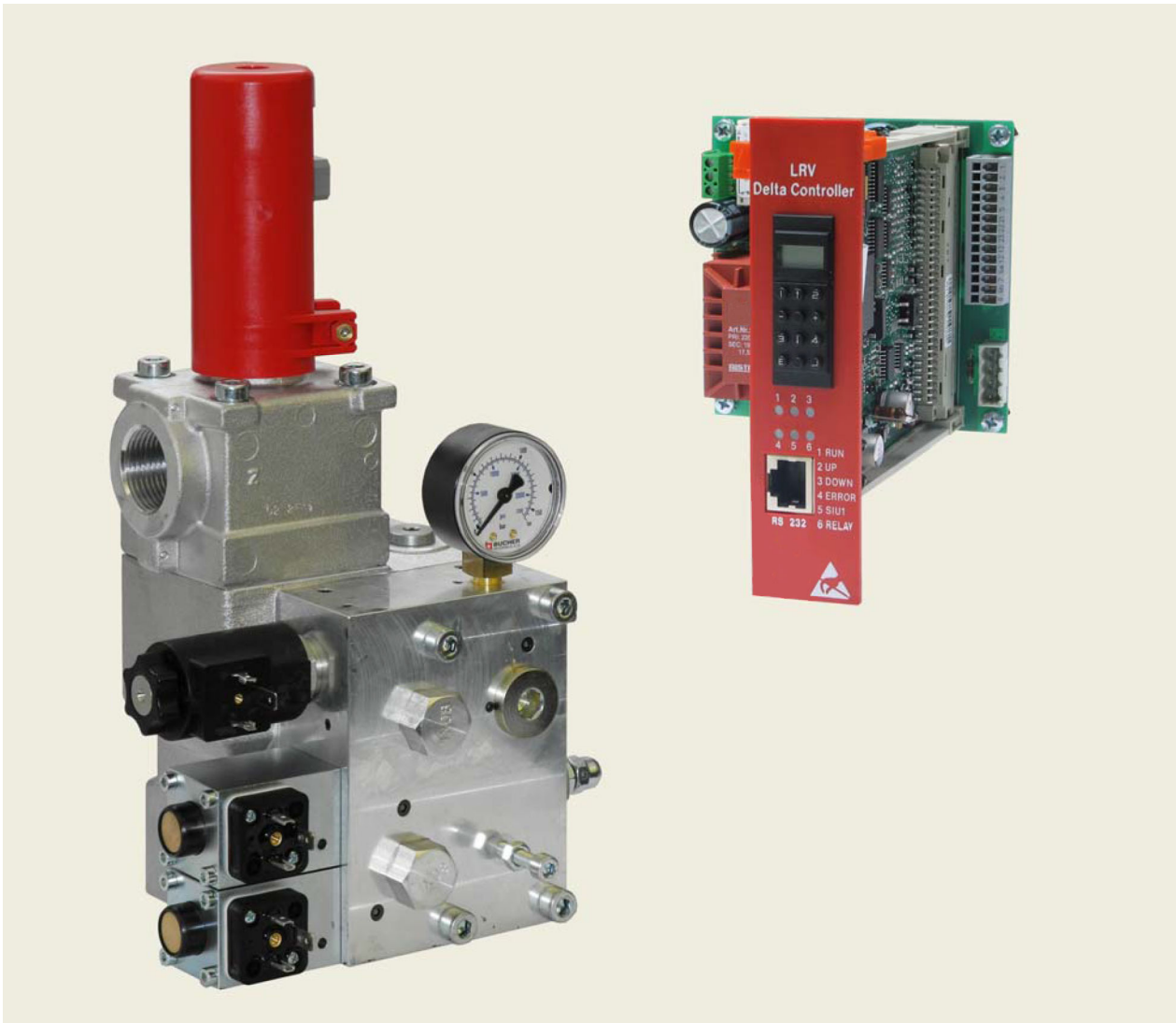

### LRV-1 Lift Control Valve, Size 175 / 350 / 700

NTA-2 power supply unit and DELCON  
Software version 2.230

---

Published by

**Bucher Hydraulics AG**  
Industriestrasse 15  
CH-6345 Neuheim

Phone +41 41 757 03 33  
Email [info.ch@bucherhydraulics.com](mailto:info.ch@bucherhydraulics.com)  
Internet [www.bucherhydraulics.com](http://www.bucherhydraulics.com)

---

Classification: 430.310.501

© 2023 by Bucher Hydraulics AG, CH-6345 Neuheim

All rights reserved. This documentation, in whole and/or in part, is protected by copyright. It may not be reproduced, nor may it be stored, processed, replicated or distributed by electronic means, without written permission from Bucher Hydraulics.

Data is provided for the purpose of product description only, and must not be construed as warranted characteristics in the legal sense. No assertion regarding either a particular property or the fitness for a particular intended purpose can be derived or deduced from this information. The information does not relieve users from the duty of conducting their own evaluations and tests.

Because the products are subject to continual improvement, we reserve the right to amend the product specifications contained in this catalogue. The original language and legal terminology of all Bucher Hydraulics documentation is exclusively German. Bucher Hydraulics cannot be held liable for any possible errors in translation.

<b>Contents</b>		<b>Page</b>
<b>1</b>	<b>General, product description</b> .....	<b>6</b>
	1.1 Target group .....	6
	1.2 Supplementary documents .....	6
	1.3 Specialist terms .....	6
	1.4 Important notes .....	7
	1.4.1 Subassemblies .....	7
	1.4.2 Intended use .....	7
	1.4.3 Conformity .....	8
	1.5 Product identification .....	9
	1.5.1 Nameplate .....	9
	1.5.2 Check number .....	9
	1.5.3 Model code .....	10
	1.6 LRV-1 lift control valve .....	11
	1.6.1 Simplified hydraulic-electrical diagram .....	12
	1.6.2 Electrical connection diagram .....	13
	1.6.3 Factory settings .....	14
	1.6.4 Description of function .....	14
	1.6.5 Technical data .....	17
	1.6.6 Pressure drop .....	19
	1.7 DELCON electronic card .....	21
	1.7.1 Factory settings .....	21
	1.7.2 Description of function .....	22
	1.7.3 Technical data .....	23
	1.7.4 Travel and switching diagram for normal travel distance .....	24
	1.7.5 Travel and switching diagram for short travel distances .....	25
	1.8 NTA-2 power supply unit .....	26
	1.8.1 Description .....	26
	1.8.2 Technical data .....	29
	1.8.3 Terminal assignments .....	30
	1.9 IWK-1 feedback cable .....	32
	1.10 Surroundings .....	32
	1.11 Emissions .....	32

---

<b>2</b>	<b>Safety instructions</b> .....	<b>33</b>
<hr/>		
<b>3</b>	<b>Operating controls and indicators</b> .....	<b>34</b>
3.1	Emergency-lowering valve (EN 81) .....	35
3.2	Display of the operating status .....	36
3.3	Miniterminal .....	36
3.4	Handterminal .....	39
3.5	Password .....	40
3.6	WinDelta32 - PC program .....	45
<hr/>		
<b>4</b>	<b>Installation and commissioning</b> .....	<b>46</b>
4.1	Installation .....	46
4.2	Assembly .....	47
4.2.1	Hose or pipe .....	47
4.2.2	Power supply unit .....	48
4.2.3	Wiring the power supply unit .....	49
4.2.4	Electrical emergency-lowering 2 x 24 VDC .....	50
4.2.5	Electrical emergency-lowering 1 x 12 or 1 x 24 VDC (option) .....	51
4.3	Commissioning/settings .....	52
4.3.1	Checking the check numbers .....	52
4.3.2	Checking the minimum static pressure .....	52
4.3.3	Bypass pressure setting .....	53
4.3.4	Setting the maximum operating pressure (EN 81) .....	56
4.3.5	Setting the demand/feedback response difference, SIU-1 .....	57
4.3.6	Setting the speed-monitoring in the unlocking zone of the door, SIU-4 .....	57
4.3.7	Setting the inspection-travel speed .....	57
4.3.8	Positioning the shaft switches for the deceleration distance .....	58
4.3.9	Setting the mechanical zero point .....	60
4.3.10	Pilot filters .....	61
4.3.11	Pipe rupture valve test .....	62
<hr/>		
<b>5</b>	<b>Operation</b> .....	<b>66</b>
5.1	Parameterisation with Handterminal .....	66
5.2	Parameterisation with Miniterminal .....	67
5.3	Overview of travel curve parameters .....	68
5.4	Overview of control parameters (PID) .....	68
5.5	Description of parameters .....	69

---

5.5.1	Demand values menu .....	69
5.5.2	Options menu .....	71
5.5.3	Zero point / Hall sensor menu .....	77
5.5.4	Information menu .....	77
5.6	Calculating the demand values for maximum speed .....	79
5.7	Faults / Fault-finding .....	80
5.7.1	Check list for fault correction .....	80
5.7.2	Error messages .....	84
5.7.3	Warnings .....	87
5.7.4	Informations .....	89
<b>6</b>	<b>Maintenance</b> .....	<b>90</b>
6.1	Maintenance schedule .....	90
6.2	Hydraulic fluids and oil additives .....	91
6.3	Installation guide for DOWN pilot valve .....	92
6.4	Spare parts .....	92

## 1 General, product description

This guide is an integral part of the product. It describes the product's safe use in all phases of operation and is valid for all model series that are referred to.

### 1.1 Target group

- Operator
- Installer
- Service engineer
- Repair technician

### 1.2 Supplementary documents

Description	Document
Lift Control Valve, Quick-Start Guide	300-P-9010169
Recommended hydraulic fluids	300-D-9010073
Installation Guideline - "Down" pilot valve	300-U-9010068
Complete Spare Parts Catalog Elevators	300-S-9010638
Life time	300-P-9010175

### 1.3 Specialist terms

Term	Definition
DELCON	Electronic control card for LRV-1 valve
NTA-2	Power supply

## 1.4 Important notes

### 1.4.1 Subassemblies

This guide differentiates between the following subassemblies:

LRV-1 lift control valve

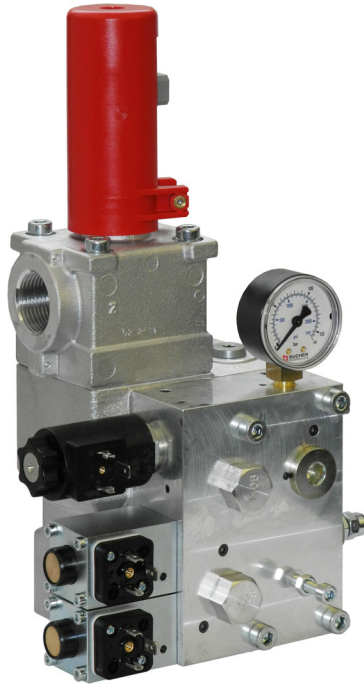

DELCON electronic control card  
on NTA-2



NTA-2 power supply unit



### 1.4.2 Intended use

Lift control valve for operating hydraulically-driven passenger and goods lifts.

The products must not be handled in any way by unauthorised persons.

### 1.4.3 Conformity

The product was designed and developed in conformity with the following directives and standards:

EU-Directive	2006/42/EC
UK Statutory Instrument	2008 No. 1597
EU-Directive	2014/33/EU
UK Statutory Instrument	2016 No. 1093
Standards	EN 81-20:2020 EN 81-50:2020
EMC Standards	EN 12015:2014 EN 12016:2013

## 1.5 Product identification

### 1.5.1 Nameplate

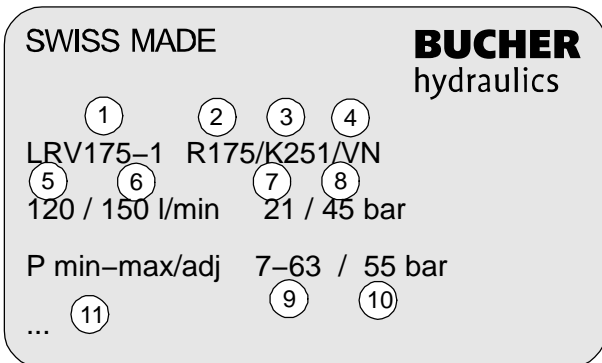

- 1 Valve type = LRV 175
- 2 Flow ring = R 175
- 3 Spool = K 251
- 4 Manual emergency-lowering valve with preload = VN
- 5 Flow rate UP = 120 l/min
- 6 Flow rate DOWN = 150 l/min
- 7 Minimum static pressure (empty car) = 21 bar
- 8 Maximum static pressure (full car) = 45 bar
- 9 Setting range = 7 ... 63 bar
- 10 Set for maximum working pressure = 55 bar
- 11 Customer specific data

### 1.5.2 Check number

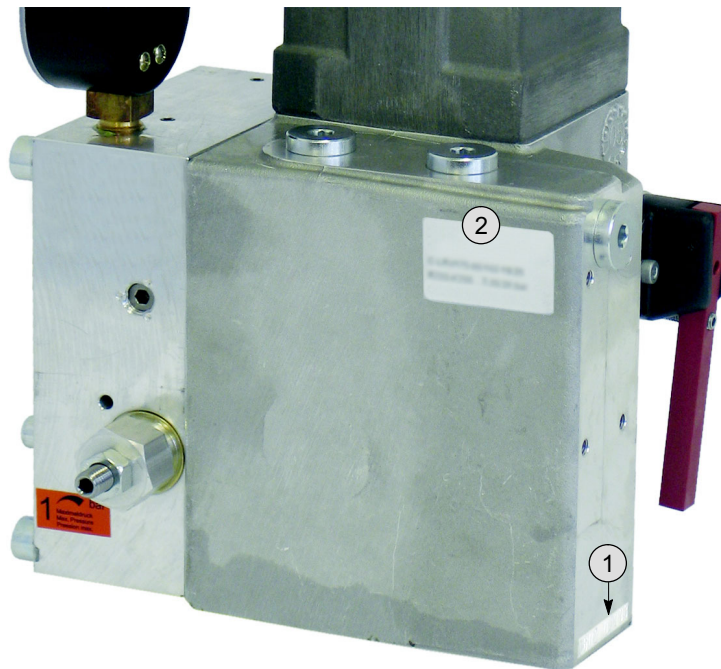

Legend		
	1	Check number
	2	Nameplate

## 1.5.3 Model code

LRV 175-1 / R 175 - K 251 / VN / EN00 / MP / D0

### Valve type/size

= LRV 175-1  
= LRV 350-1  
= LRV 700-1

### Flow range: flow rate/type

LRV 175-1	15 ... 45 l/min	= R 45
	46 ... 90 l/min	= R 90
	91 ... 175 l/min	= R 175
	176 ... 250 l/min	= R 250
LRV 350-1	150 ... 250 l/min	= R 250
	251 ... 350 l/min	= R 350
	351 ... 500 l/min	= R 500
LRV 700-1	400 ... 700 l/min	= R 700
	701 ... 1000 l/min	= R 1000

### Spool: flow rate/type

LRV 175-1	15 ... 90 l/min	= K 91
	91 ... 250 l/min	= K 251
LRV 350-1	150 ... 500 l/min	= K 501
LRV 700-1	400 ... 1000 l/min	= K 1001

### Manual emergency-lowering valve

Emergency-lowering valve with preload = VN  
Emergency-lowering valve without preload = SN

### Electrical emergency-lowering valve

without electrical emergency-lowering valve = EN 00  
with DC solenoid 12 V = EN 12  
with DC solenoid 24 V = EN 24\*

\* further option: via NTA-2 with 2x24 V batteries,  
⇒ page 30, chapter 1.8.3 and page 50, chapter 4.2.4

### Test port

without test nipple (female thread G $\frac{1}{2}$ " ) = OP  
with test nipple (DIN 16271) = MP

### DELCON type

without DELCON = D0  
with DELCON = D1

1.6 LRV-1 lift control valve

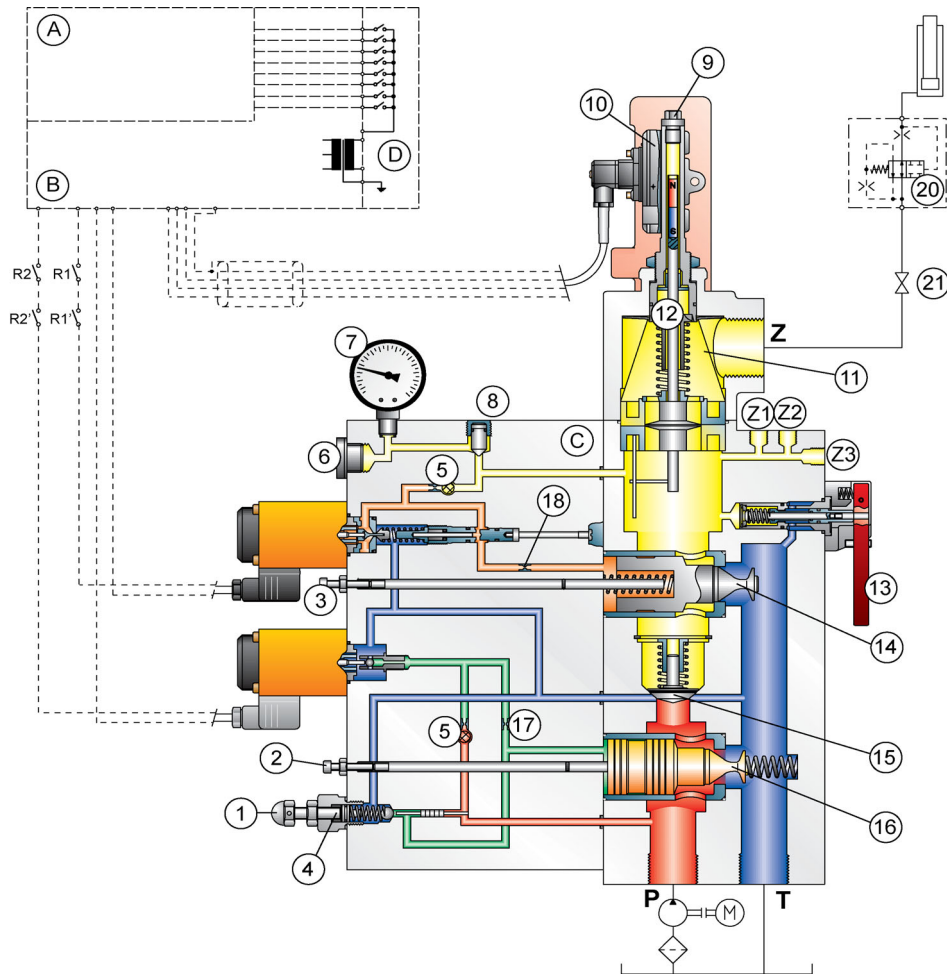

<b>Legend</b>	1	Maximum-pressure setscrew	9	Air-bleed screw
	2	Bypass-pressure setscrew	10	Hall sensor
	3	Lowering-speed limiter (valve size 700 only)	11	Main filter
	4	Pressure-relief valve	12	Flow-rate measuring system
	5	Pilot filter	13	Emergency-lowering valve
	6	Test port, G½	14	DOWN spool
	7	Pressure gauge	15	Check valve
	8	Pressure gauge shut-off screw (valve sizes 175 and 350)/ Pressure gauge shut-off valve (valve size 700)	16	UP spool
			17	UP damping jet
			18	DOWN damping jet
			20	Pipe rupture valve
			21	Ball valve
	P	Pump port	A	DELCON
	T	Tank port	B	NTA-2
	Z	Cylinder port	C	LRV-1
	Z1	Pressure switch port	D	Control cabinet (customer's)
	Z2	Pressure switch port		
	Z3	Hand pump port		

## 1.6.1 Simplified hydraulic-electrical diagram

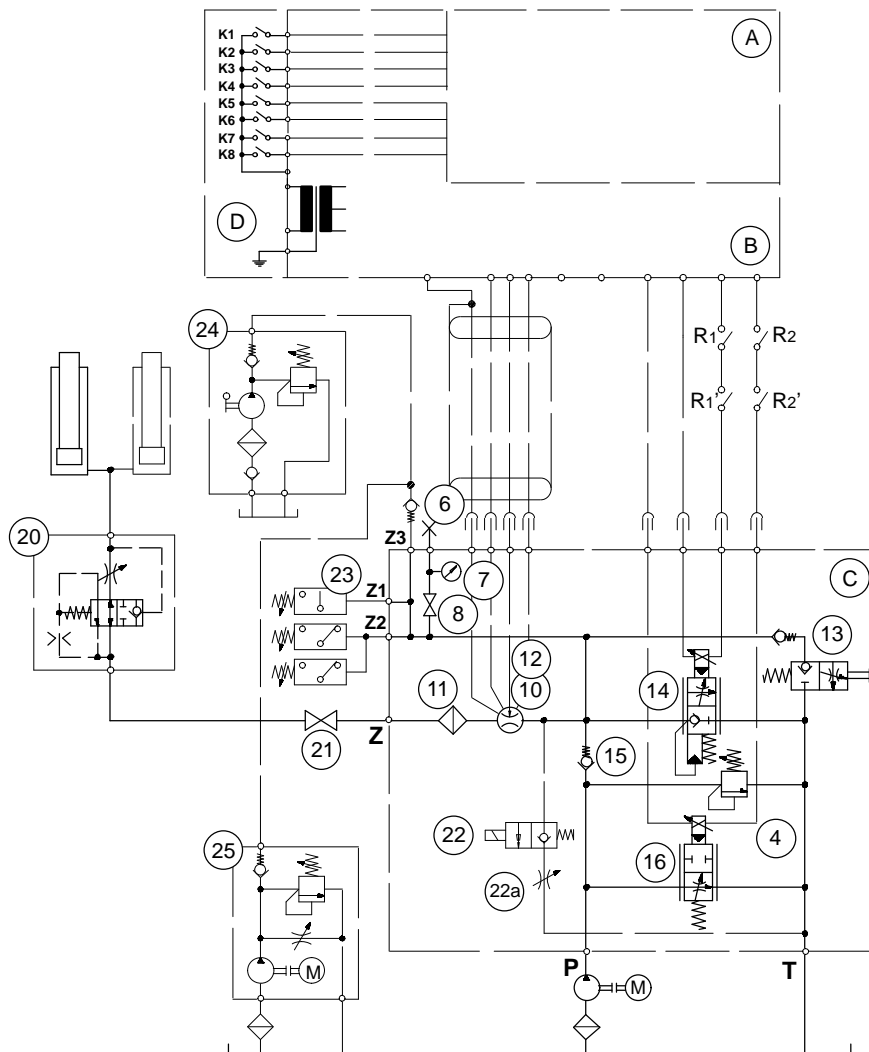

Legend	
4	Pressure-relief valve
6	Test point, G $\frac{1}{2}$
7	Pressure gauge
8	Pressure gauge shut-off screw/ valve
10	Feedback sensor (non-contacting)
11	Main filter
12	Flow-rate measuring system
13	Emergency-lowering valve
14	DOWN spool
15	Check valve
16	UP spool
20	Pipe-rupture valve
21	Ball valve
22	Elec. emergency lowering (opt.)
22a	Speed set. elec. emerg. low.
23	Pressure switch
24	Hand pump
25	Relevelling (optional)
P	Pump port
T	Tank port
Z	Cylinder port
Z1	Pressure switch port
Z2	Pressure switch port
Z3	Hand pump port
R <sub>1</sub>	to EN 81
R <sub>2</sub>	to EN 81
A	DELCON
B	NTA-2
C	LRV-1
D	Control cabinet (customer's)

1.6.2 Electrical connection diagram

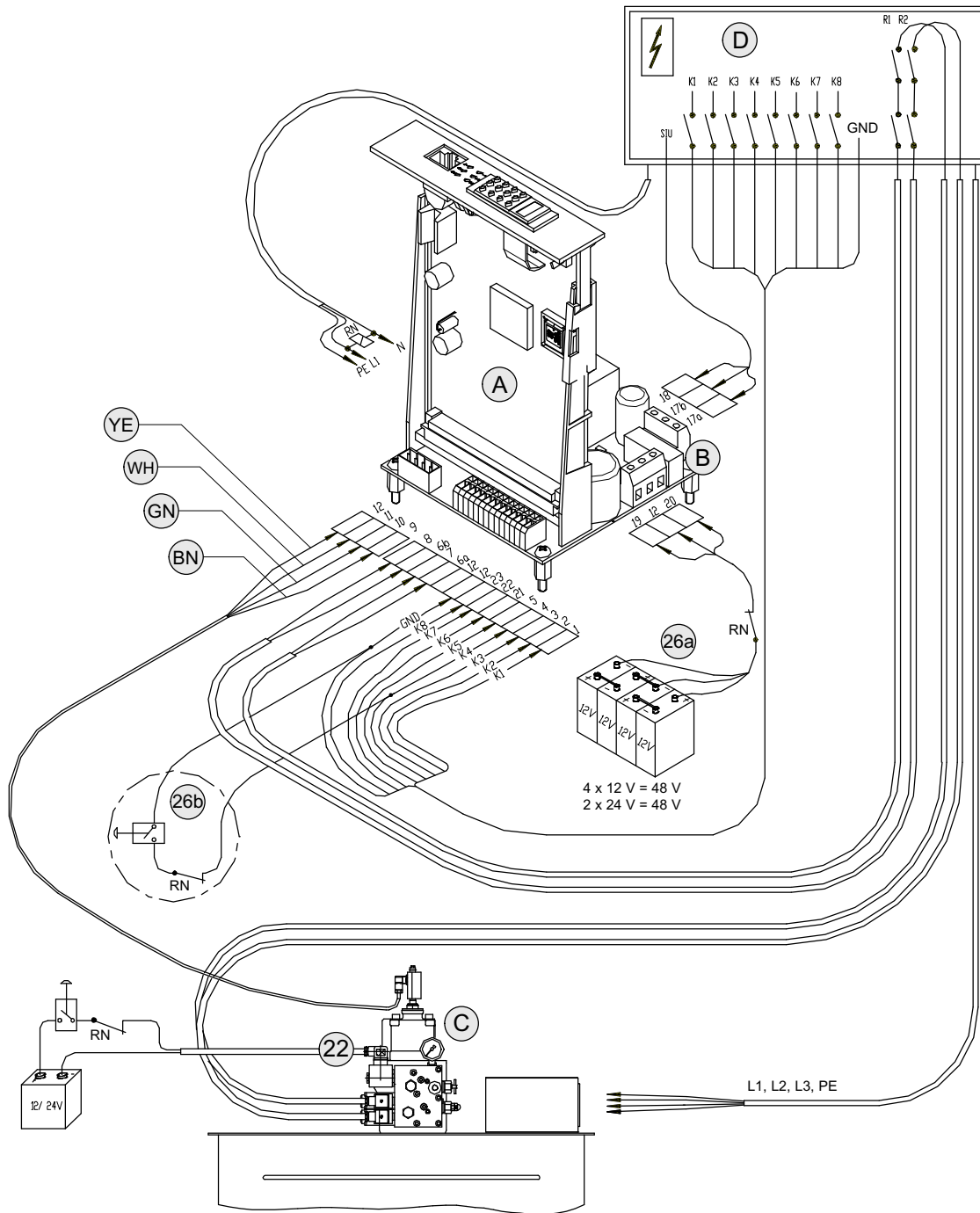

300-1-10009306

Legend	A	DELCON	22	Electrical emergency-lowering 12 or 24 VDC (option) ⇒ page 51, chapter 4.2.5
	B	NTA-2	26a/b	Electrical emergency-lowering 2 x 24 VDC ⇒ page 50, chapter 4.2.4
	C	LRV-1	R <sub>1</sub>	to EN 81
	D	Control cabinet (customer's)	R <sub>2</sub>	to EN 81
	BN	brown		
	GN	green		
	WH	white		
	YE	yellow		

### 1.6.3 Factory settings

All valves are factory-set to the values for the particular installation and then tested.

- Pressure-relief valve set to the maximum working pressure
- Bypass pressure as per the calculated minimum static pressure
- Emergency-lowering valve set to 5...10 % of maximum DOWN speed
- Mechanical zero point of the feedback sensor

### 1.6.4 Description of function

The lift control valve can be subdivided into 3 main functions.

#### 1. UP section / pressure-relief valve

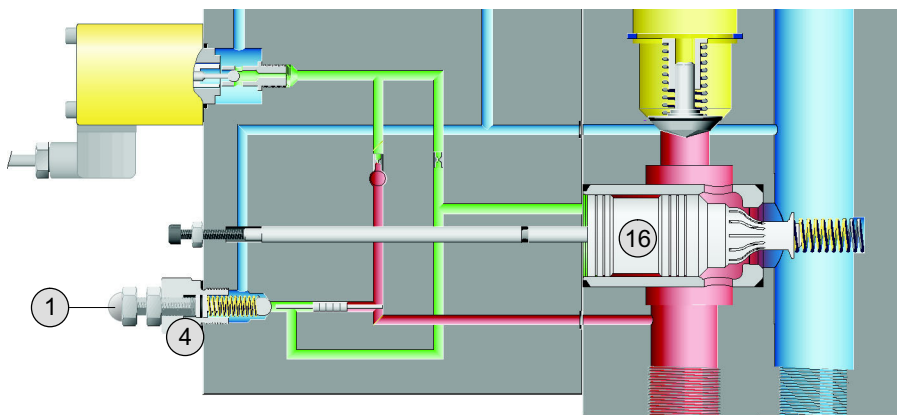

- Initial position:  
UP spool (16) is open in the 0 position; pump flow goes directly to tank
- Up travel / acceleration:  
UP spool (16) is progressively closed by the electro-proportional valve (UP solenoid); this results in smooth acceleration of the lift up to maximum speed
- Deceleration:  
UP spool (16) is progressively opened by the electro-proportional valve (UP solenoid); this results in smooth deceleration of the lift to standstill
- Overload:  
pressure-relief valve (4) and UP spool (16) open when the maximum working pressure set with screw (1) is reached

## 2. DOWN section / Emergency-lowering valve

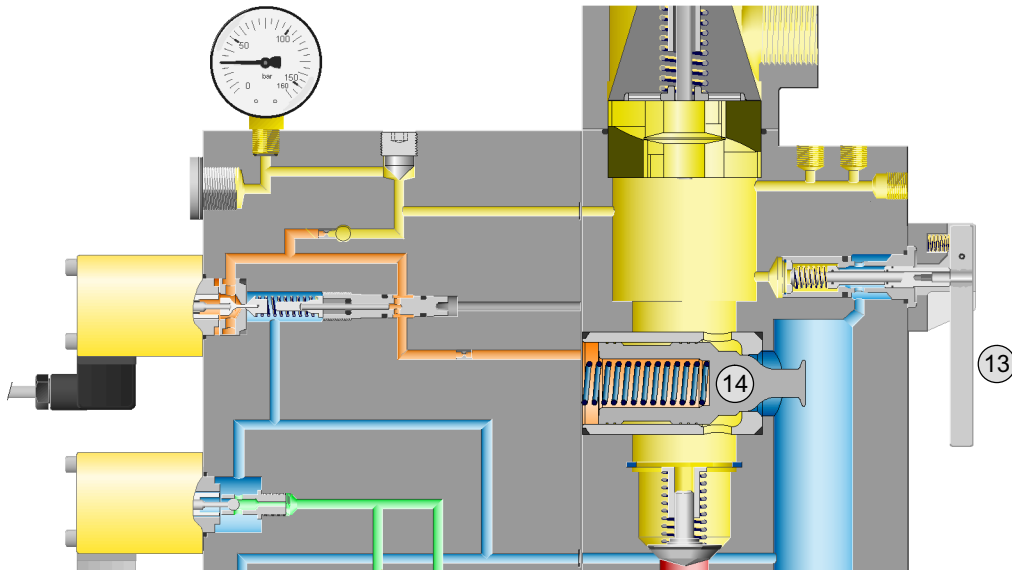

The down section is constructed in a similar way to the up section.

- Initial position:  
DOWN spool (14) is closed leak-free in the 0 position
- DOWN travel / acceleration:  
DOWN spool (14) is progressively opened by the electro-proportional valve (DOWN solenoid); this results in smooth acceleration
- Deceleration:  
DOWN spool (14) is progressively closed by the electro-proportional valve (DOWN solenoid); this results in smooth deceleration of the lift to standstill
- Power failure/ evacuation:  
With the electrical emergency-lowering valve (optional), the car can be lowered using DC voltage (⇒ page 51, chapter 4.2.5)
- The car can be lowered slowly with the manual emergency-lowering valve (13)

### 3. Flow-rate measuring system

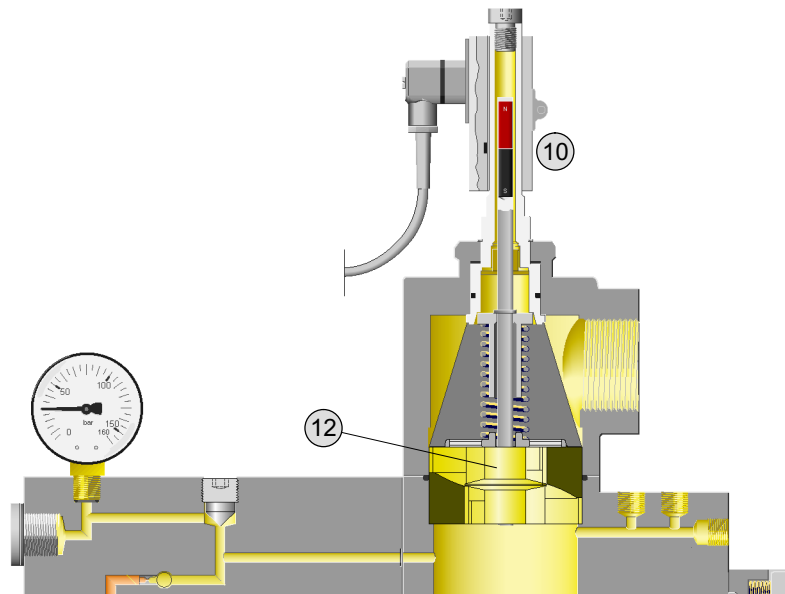

- The oil flows through the flow meter (12) in both the up and down directions
- The baffle-disc is displaced axially as a function of the flow rate
- This axial displacement is converted by a non-contacting feedback transducer (10) into an electrical DC signal (the feedback signal), which is then sent to the DELCON
- The output signal (the feedback) is proportional to the flow rate
- The controller in the DELCON works to match the feedback value to the demand signal

1.6.5 Technical data

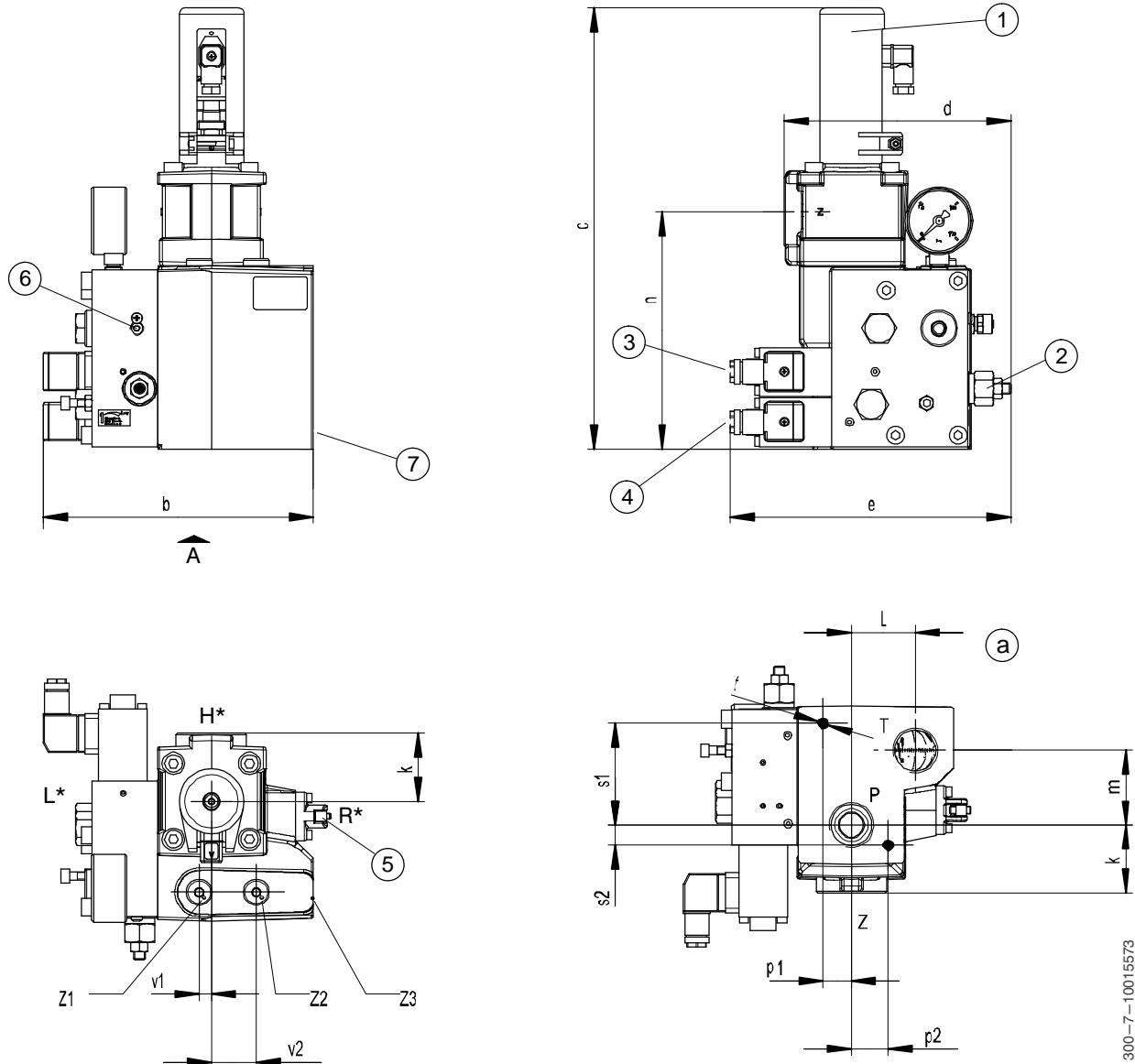

<b>Legend</b> View: valve sizes 175 and 350	1	Flow-rate measuring system	5	Orientation of Z-port
	2	Pressure-relief valve	6	Pressure gauge shut-off screw (valve sizes 175 and 350)/ Pressure gauge shut-off valve (valve size 700)
	3	DOWN solenoid	7	Test number (embossed)
	4	UP solenoid	a	View from below
	Z1	Pressure switch port		<b>Orientation of Z-port</b> (specify when ordering!)
	Z2	Pressure switch port		H* rear (standard)
	Z3	Hand pump port		L* left
	P	Pump port		R* right
	T	Tank port		
	Z	Cylinder port		

Type	Ports Z, T, P	Ports Z1, Z2, Z3	Weight [kg]	Max. pressure [bar]
LRV 175-1	G1	G $\frac{1}{4}$	8	80
LRV 350-1	G1 $\frac{1}{2}$	G $\frac{1}{4}$	11	80
LRV 700-1	G2, G2 $\frac{1}{2}$ , G2	G $\frac{1}{4}$ , G $\frac{1}{4}$ , G $\frac{3}{8}$	22.5	67

Type	Dimensions [mm]														
	b	c	d	e	k	L	m	n	p1	p2	s1	s2	t	v1	v2
LRV 175-1	199	325	182	208	50	47	55	175	21	27	75	15	M8	9	23
LRV 350-1	219	355	205	208	65	48	63	200	35	38	85	25	M10	14	28
LRV 700-1	297	428	255	225	80	87	83	265	48	56	124	41	M10	30	30

- The permissible temperature range is determined by the permissible viscosity range of 20...500 cSt
- Regardless of the viscosity, the temperature must not fall below 0 °C and must not exceed 70 °C
- For detailed information ⇒ page 91, chapter 6.2

### 1.6.6 Pressure drop

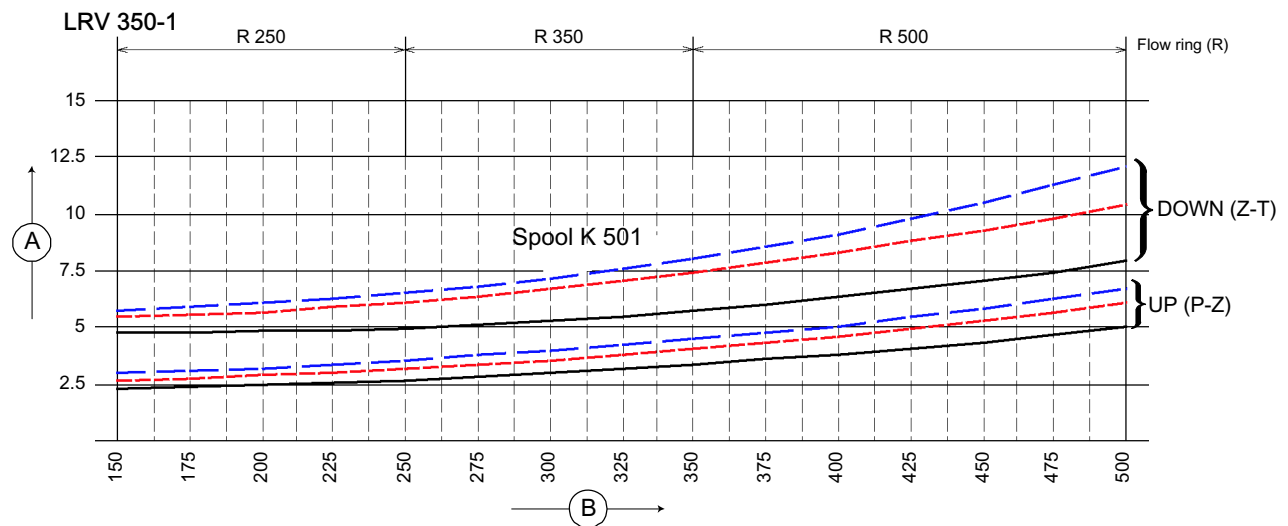
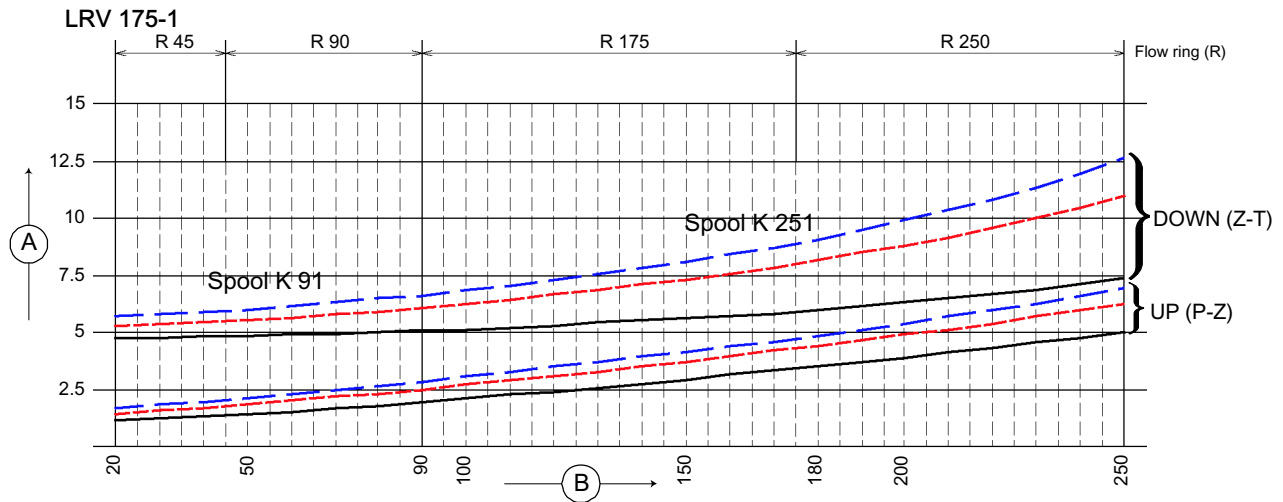

Legend	<b>A</b>	Pressure drop [bar] min. required dynamic pressure
	<b>B</b>	Flow rate Q [l/min.]
		500 cSt (Motorex Corex HLP 46 at approx. 2 °C)
		300 cSt (Motorex Corex HLP 46 at approx. 7.5 °C)
		75 cSt (Motorex Corex HLP 46 at approx. 30 °C)

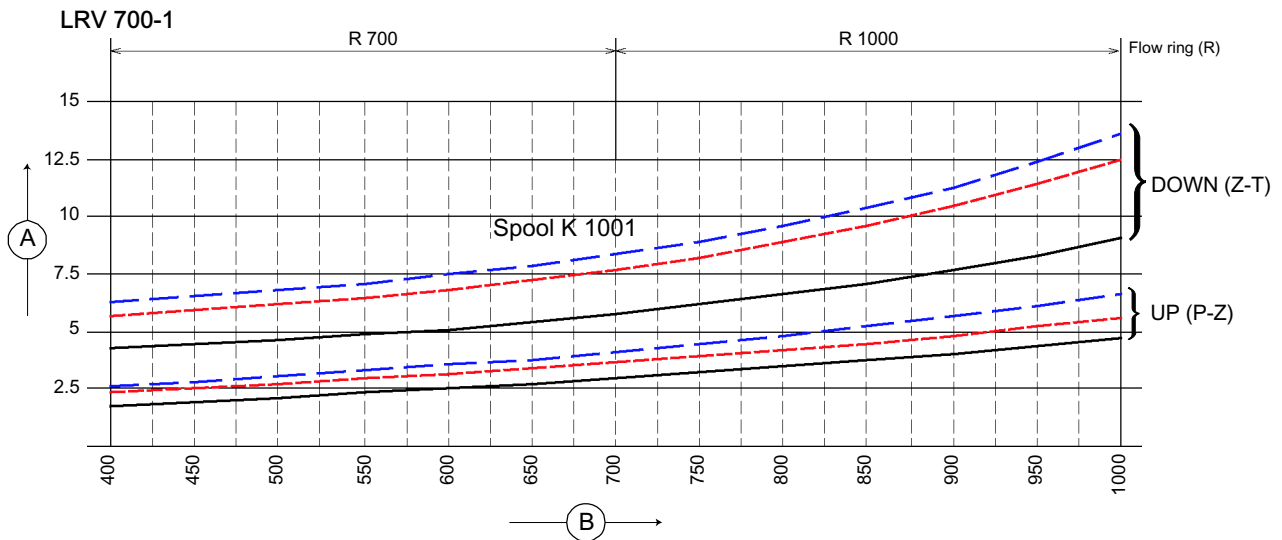

Legend	<b>A</b>	Pressure drop [bar] min. required dynamic pressure
	<b>B</b>	Flow rate Q [l/min.]
		500 cSt (Motorex Corex HLP 46 at approx. 2 °C)
		300 cSt (Motorex Corex HLP 46 at approx. 7.5 °C)
		75 cSt (Motorex Corex HLP 46 at approx. 30 °C)

## 1.7 DELCON electronic card

The DELCON controls the oil flow - and therefore the lift's travel profile - in accordance with a preset curve.



### ATTENTION!

#### Electrostatic discharge (ESD)

The DELCON can be damaged by incorrect handling.

Always keep the DELCON in its ESD protective bag and only hold it by the front panel.

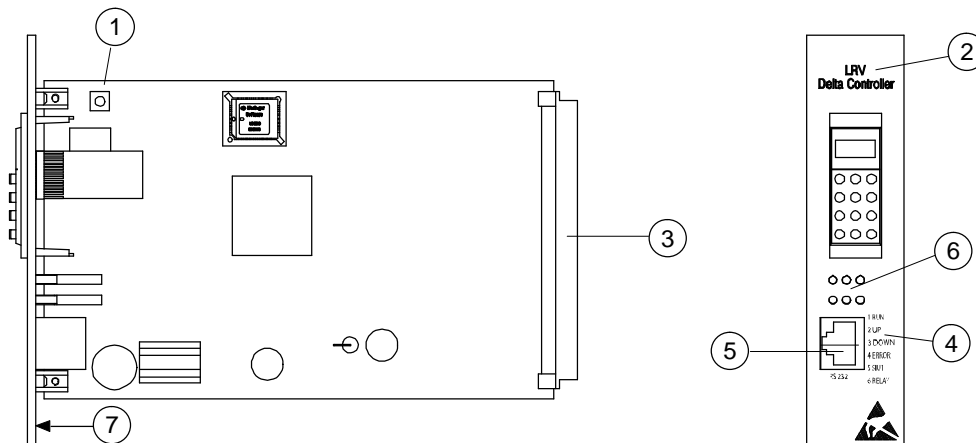

#### Legend

1	RESET button (restarts the program in the DELCON electronic card)
2	Nameplate
3	Label with serial number
4	Description of LED functions
5	RS-232 port
6	LED
7	Label with check number and demand values

### 1.7.1 Factory settings

- Maximum UP and DOWN speeds
- Slow speed set to 5 ... 10 % of maximum speed
- Acceleration/deceleration set to mid-range value
- Inspection travel speed set to 40 % of maximum speed

## 1.7.2 Description of function

- The lift control system sends the command signals to the DELCON via potential-free relay contacts or semiconductors
- The feedback value is compared with the demand travel curve and controlled throughout the whole travel
- Deviations from the demand curve are corrected by the UP and DOWN proportional solenoids
- The closed-loop control ensures that the travel characteristics are independent of load and temperature
- The inspection speed can be set through command K5 of the lift control system (there is no monitoring of maximum permissible demand/feedback deviation during travel at inspection speed!)
- Reduced speeds for short travel distances are also possible via command signals K6...K8
- The DELCON enables soft-stopping (gentle halt) with very accurate positioning ( $\pm 3$  mm)

### Features

- The travel curve for the up and down directions is set and adjusted with the Miniterminal, the Handterminal or a PC
- The demand curve can be set and checked at the DELCON while the lift is at standstill
- Measured values can be checked with the Handterminal
- The DELCON card is easy to exchange (1 card for all valves), which means that rapid fault-fixing is ensured

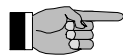

**IMPORTANT!:** If the DELCON is exchanged, the installation-specific parameters must be replicated in the new card.

### 1.7.3 Technical data

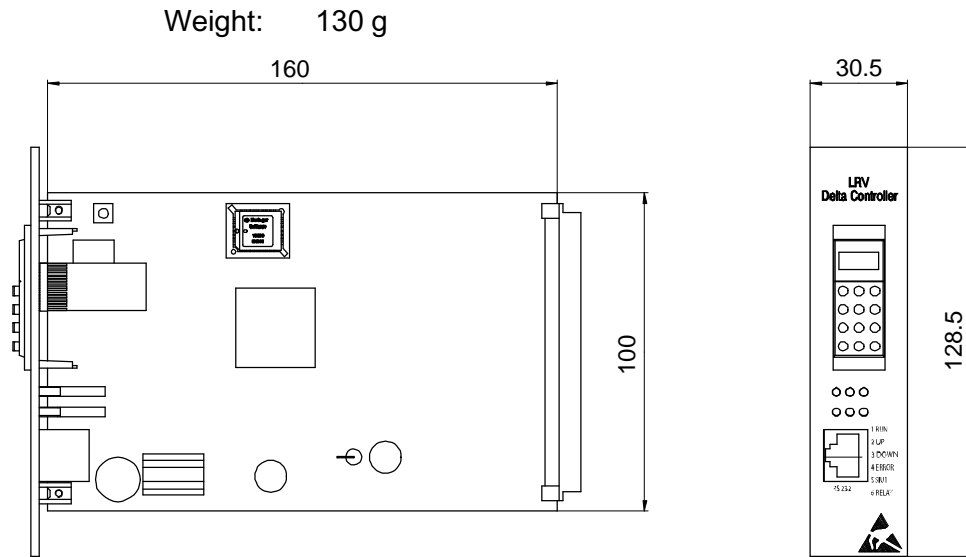

#### General description

- Digital electronic card for the LRV-1 valve
- Enhanced ride comfort
- Automatic reduction of demand signal if nominal speed is not attained
- Extended functions
- Simple set-up
- Easy to trouble-shoot

#### New installations

- Factory settings permanently stored

#### Replacement cards

- Contain basic settings  
For installation-specific settings ⇒ page 66, chapter 5

## 1.7.4 Travel and switching diagram for normal travel distance

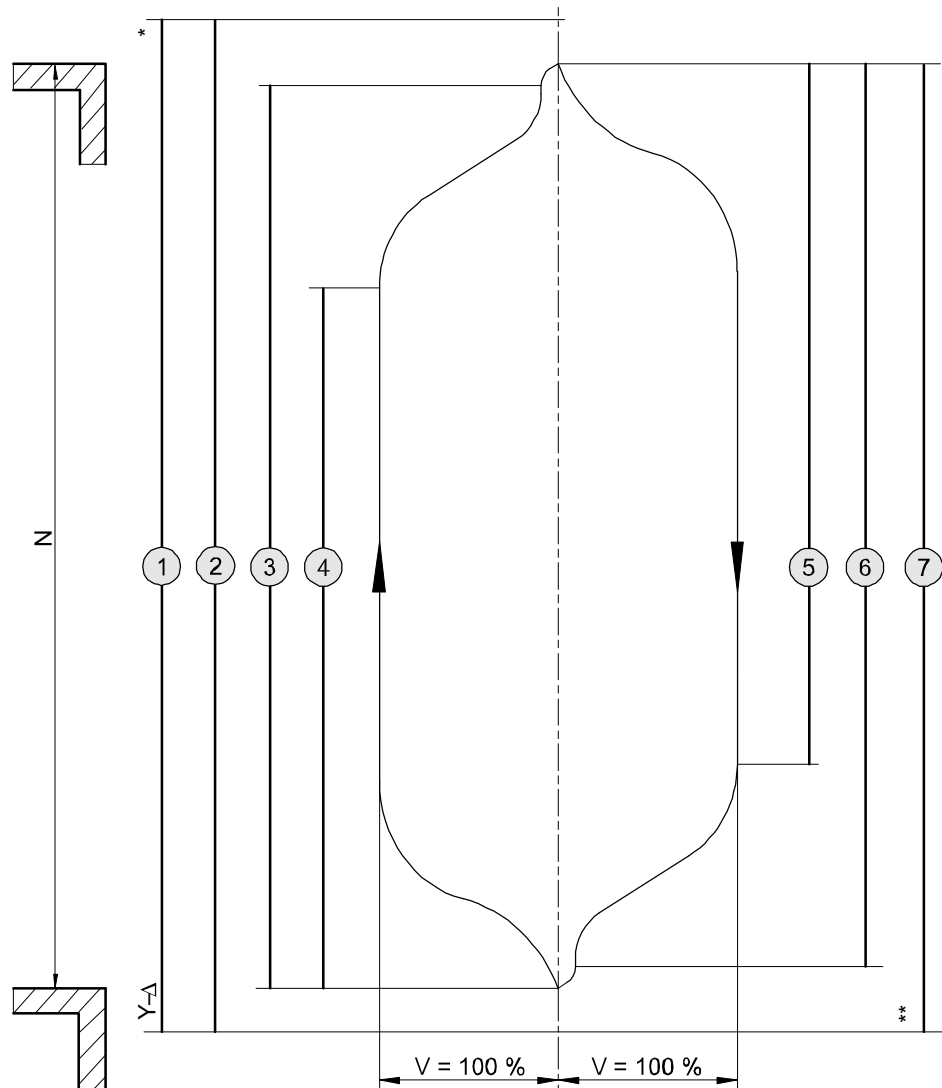

\* Motor run-on time of 0.5 ... 1 s

\*\* Drop-out delay of 0.5 ... 1 s, after drop out of K4

Y-Δ Y starting time of up to approx. 3 s with Y-Δ, K1 and K2 not until Δ connection

Legend	1	2	3	4	5	6	7
	Motor contactor ON	Safety relay R2 closed	K2 "Slow UP" is present	K1 "Fast UP" is present	K3 "Fast DOWN" is present	K4 "Slow DOWN" is present	Safety relay R1 closed
	N	Normal distance between floors					

### 1.7.5 Travel and switching diagram for short travel distances

The electronics of the LRV-1 valve make it possible to control stops at mezzanines and similar short travel distances with the same ride comfort as in normal travel.



**IMPORTANT!** The maximum speed (auxiliary speed) should be reduced to a value that, despite the short travel distance, can actually be attained.

Short distance between floors with normal speed  
(slow-speed travel distance too long)

Short distance between floors with reduced auxiliary speed (K6)

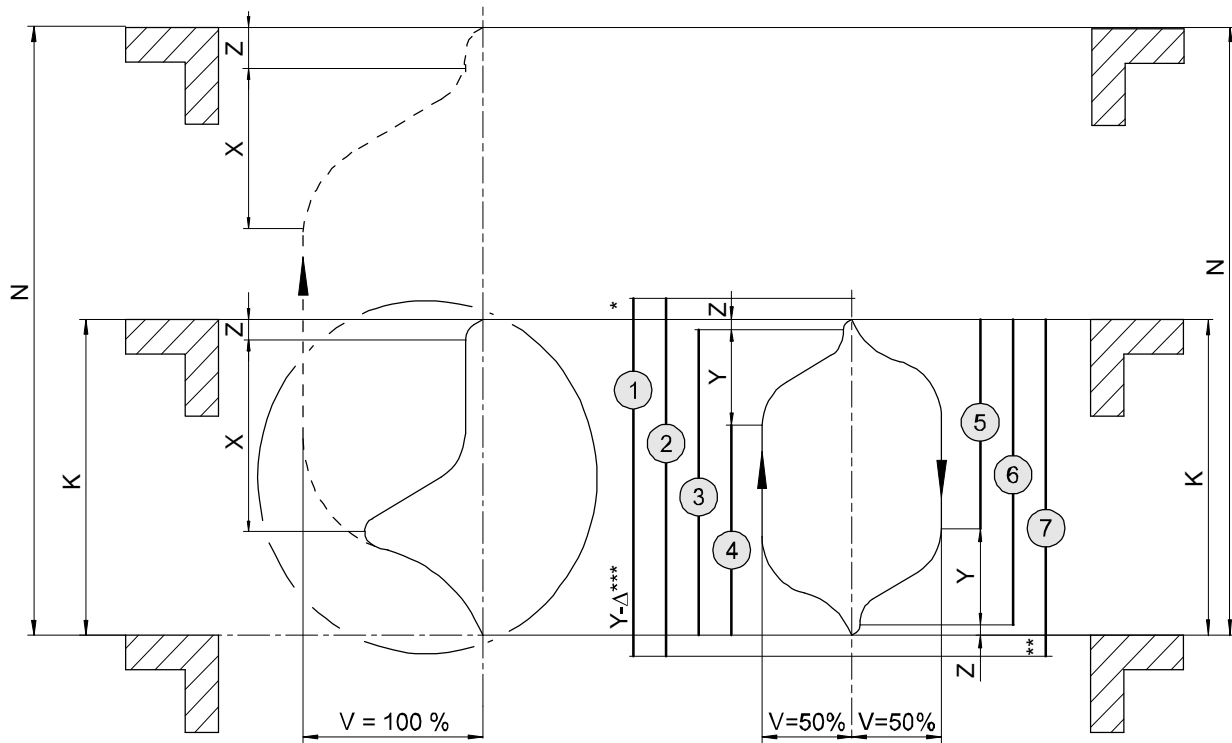

- \* Motor run-on time of 0.5 ... 1 s
- \*\* Drop-out delay of 0.5 ... 1 s, after drop out of K4 + K6
- \*\*\* K1 and K2 not until  $\Delta$  connection
- V Adjust the speed to suit the circumstances (e.g. 50 %)
- X Deceleration switch at normal speed
- Y Deceleration switch at reduced speed
- Z Soft-Stop is not separately adjustable

Legend	
1	Motor contactor ON
2	Safety relay R2 closed
3	K2 + K6 are present
4	K1 is present
5	K3 is present
6	K4 + K6 are present
7	Safety relay R1 closed
N	Normal distance between floors
K	Short distance between floors

- By using command signals K6, K7 or K8, various reductions in the nominal speed can be achieved (e.g. for different floor spacings)
- The speed reduction can be adjusted between 20 ... 100 % of nominal speed

- Speed can be set by means of parameter "K6 speed" (or "K7 speed" / "K8 speed") in the Options menu to match the floor spacing (distance between stops)
- Acceleration can be adjusted separately via parameters "K6 acceleration" (or "K7 acceleration" / "K8 acceleration") in the Options menu
- Deceleration can be adjusted separately via parameters "K6 deceleration" (or "K7 deceleration" / "K8 deceleration") in the Options menu

## 1.8 NTA-2 power supply unit

The NTA-2 power supply unit provides both power supply and physical support for the DELCON.

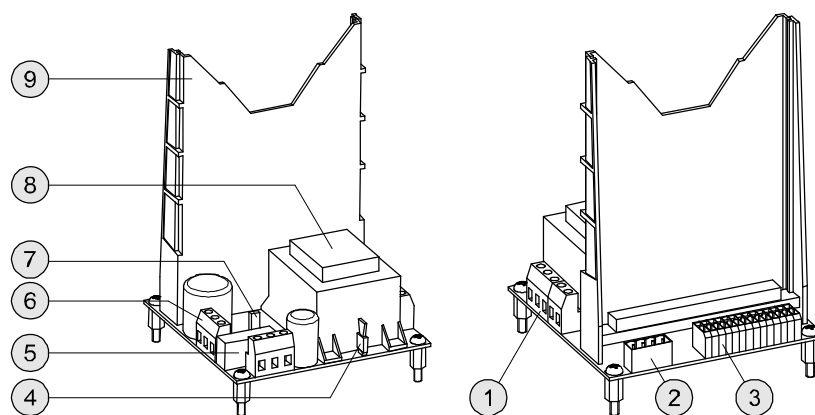

300-1-10008856

Legend	1	Mains voltage terminals	6	Terminal block for emergency power supply
	2	Socket for feedback cable	7	Jumper JP1 (inversion of relay function)
	3	Terminal block (screwless)	8	Transformer
	4	Jumper JP2 (connects Earth and Signal GND)	9	Card-holder for DELCON
	5	Terminal block for SIU connection		

### 1.8.1 Description

The power supply unit is connected directly to the main supply.

The control signals for the DELCON are connected to the terminal block (3).

Through the terminals 18-17a (N.O. make contact)  
18-17b (N.C. break contact)

a relay output is provided.

Its function is defined in the DELCON by the settings of the "SIU type" and "Relay function" parameters.

### Parameter "SIU type"

1	SIU-1: relay switches when the demand/feedback difference is exceeded (there is no SIU-1 monitoring during inspection speed with K5!).
1 + 4	SIU-1 (functions as above) and SIU-4: relay switches when the speed set with the parameter "SIU-4 threshold" is exceeded.
EN81-20	Monitoring of earth fault in the solenoid actuation circuit and SIU-1. Relay switches in case of an earth fault or SIU-1 (function see above)

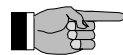

**IMPORTANT!:** To ensure that the DELCON-card can detect an earth fault, GND and earth must be interconnected.

North  
America

- as in "EN81-20", but additionally
- actual value monitoring regarding plausibility and edge during slow speed
- check the solenoid actuation circuit
- During power-up no move command must be present
- special installation run with K2/K4 and K8

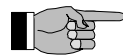

**IMPORTANT!:** check mechanical zero point setting ⇒ see chapter 4.3.9

### Parameter "Relay function"

only SIU1	The relay on the power supply unit switches only when there is an SIU-1 fault.
all errors	The relay on the power supply unit switches with any fault.
only SIU4	The relay on the power supply unit switches only when there is an SIU-4 fault.
all errors +FT	The relay on the power supply unit switches whenever an error occurs and additionally at standstill if command signal K7 is activated.

For a detailed overview of the combined effects of the parameters "SIU type" and "Relay function", ⇒ table on page 75

### JP1 selects the relay's passive state:

1-2	Current flows through the relay in its passive state (no current when function is activated)
2-3	No current through the relay in its passive state (current flows when function is activated)

Feeding of the power supply unit	Use of relay terminals	Setting JP1
Permanent feeding	17a, 18	1-2
Power supply unit operated in safety circuit*	17b, 18	2-3

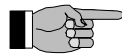

**IMPORTANT!:** Operating the power supply unit in the safety circuit allows the omission of the safety relays R1 and R2, however, it involves the following disadvantages:

- The frequent powering up and down reduces the service life of the DELCON electronic card
- To set the mechanical zero point, the power-supply unit must be fed with the safety-circuit voltage
- The soft-stop will not function correctly if the input voltage is switched off immediately
- After closing the safety circuit, there must be a pause of around 0.5 seconds before a command signal K1 ... K8 can be applied
- Delays of up to 2 seconds may occur until the lift starts

Bucher Hydraulics therefore discourages the operation of the power supply unit in the safety circuit.

The jumper JP2 connects the terminals 12 of the command signal terminal strip to the terminal PE of the mains voltage connection, earthing the reference potential of the command inputs (standard setting).

### ATTENTION!

#### Creating an earth loop

Earth loops can cause malfunctions.

If the jumper JP2 is set, the reference potential of the command input must not be earthed a second time on the lift-control side.

If the reference potential of the command inputs cannot be insulated from earth on the lift-control side, the jumper JP2 must be removed.

### ATTENTION!

#### Damage to the DELCON electronic card

Connecting the NTA-2 to the mains WITHOUT a DELCON inserted will charge capacitors on the NTA-2, and the charges will persist for a long time.

Inserting the DELCON into a NTA-2 whose capacitors are charged can damage the DELCON.

A NTA-2 without a DELCON inserted must NOT be connected to the mains at any time.

## 1.8.2 Technical data

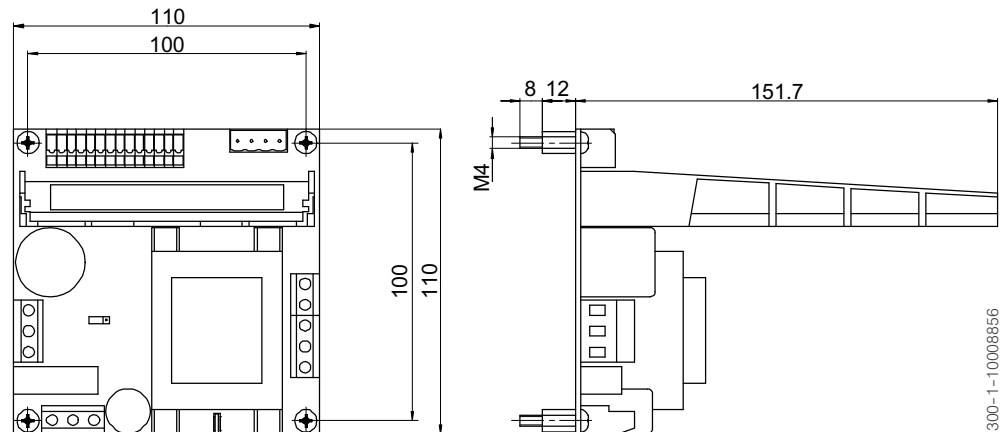

Weight	0.675 kg	
Mains voltage	NTA-2/115 100/(110)115/120 VAC ±10 % NTA-2/230 220/230/240 VAC ±10 % NTA-2/400 380/400(415)/440 VAC ±10 %	
Frequency	50/60 Hz ±10 %	
Power consumption	20 W during travel, approx. 8 W at standstill	
EMC standards	EN 12015, EN 12016	
Protection class	IP 00	
Relay contacts	$I_{\min} = 10 \mu\text{A}$ $I_{\max} = 3 \text{ A (230 VAC)}$ $3 \text{ A (30 VDC)}$ $0.3 \text{ A (100 VDC)}$	
Command inputs	Command present	$U < 2.5 \text{ V}$
	Command current	$\approx 6 \text{ mA}$
	Command not present	$U > 10 \text{ V}$

## 1.8.3 Terminal assignments

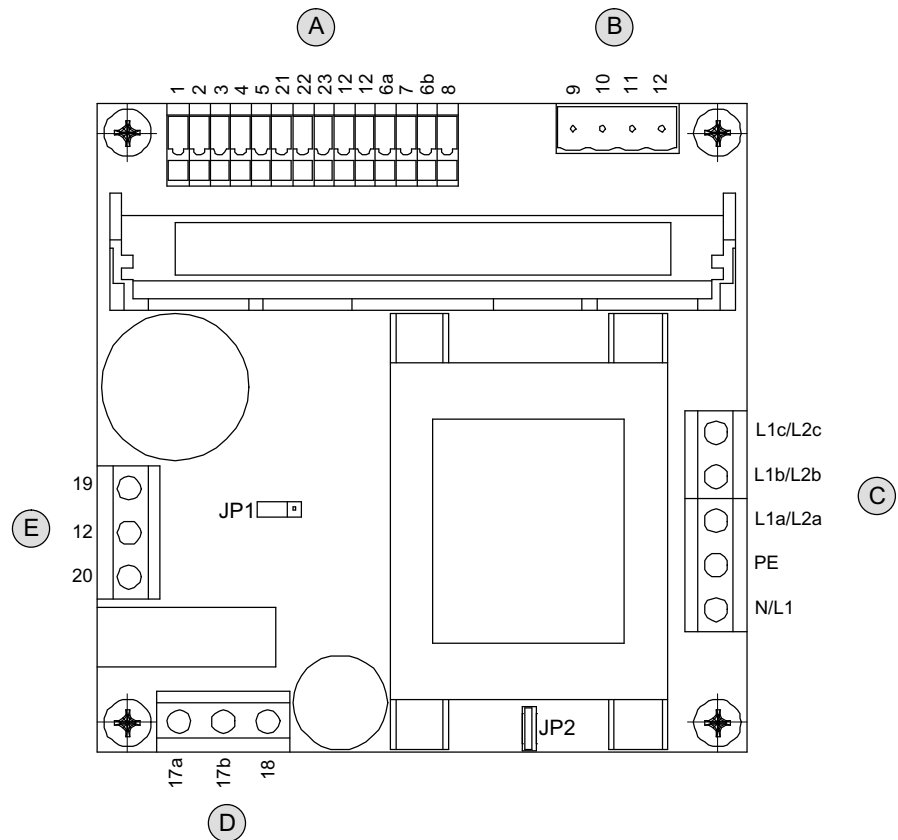

Legend	A	Control signals	D	Demand / feedback monitoring
	B	Connection for feedback cable	E	Emergency power supply
	C	Mains voltage connection		

Terminal	Description		
<b>Mains Voltage Connection</b>			
	NTA-2/115	NTA-2/230	NTA-2/400
N/L1	Neutral (N)	Neutral (N)	Phase (L1)
L1a/L2a*	Phase (L1): 120 V	Phase (L1): 240 V	Phase (L2): 440 V
L1b/L2b*	Phase (L1): (110)/115 V	Phase (L1): 230 V	Phase (L2): 400/(415) V
L1c/L2c*	Phase (L1): 100 V	Phase (L1): 220 V	Phase (L2): 380 V
* connect only one of the 3 terminals			
PE	Earth terminal		

Terminal	Description
<b>Command signals (with setting command input to "Bucher K1..K8")</b>	
1	K1 Fast UP
2	K2 Slow UP
3	K3 Fast DOWN
4	K4 Slow DOWN
5	K5 Inspection speed
21	K6 Speed reduction (auxiliary speed)
22	K7 Speed reduction (auxiliary speed)
23	K8 Speed reduction (auxiliary speed)
12	Ground/reference potential (GND) for command inputs (K1...K8)
12	Ground/reference potential (GND) for command inputs (K1...K8)
6a	Common, DOWN solenoid
7	Output, DOWN solenoid
6b	Common, UP solenoid
8	Output, UP solenoid
<b>Demand / feedback monitoring</b>	
17a	Relay output for monitoring the demand/feedback deviation (SIU-1) or the speed in the unlocking zone (SIU-4). ⇒ page 26, chapter 1.8.1 and table on page 75
18	
17b	
<b>Connection for feedback cable</b>	
9	Stabilised voltage supply +15 V
10	Feedback signal (input)
11	Stabilised voltage supply -15 V
12	Ground, Hall sensor (GND)
<b>Emergency power supply</b>	
19	+24 V emergency power supply
12	Ground, emergency power supply (GND)
20	-24 V emergency power supply

## 1.9 IWK-1 feedback cable

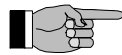

**IMPORTANT!** The feedback cable must be run from the lift control valve directly to the NTA-2 power supply unit without any intermediate terminals. Any discontinuity in the feedback cable (break, kink, etc.) can endanger trouble-free operation.

It is essential that connection 2 is ground-bonded to terminal 12, otherwise the zero point of the sensor will not be stable.

If you cut the cable to length and terminate it yourself, be sure to wire it correctly in accordance with the following diagram:

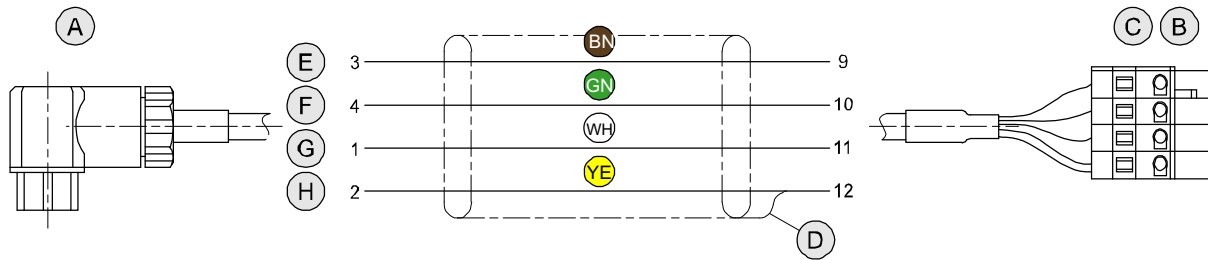

Legend	A	Line socket with PG7 gland	E	Supply +15 V
	B	NTA-2 connector	F	Signal 0 ... ±13.4 V
	C	WAGO plug	G	Supply -15 V
	D	Screen	H	Ground
Colours	BN	brown	WH	white
	GN	green	YE	yellow

## 1.10 Surroundings

For reliable operation, the following conditions must be maintained in the surroundings:

Surroundings	Requirement
Machine room temperature	2...40 °C
Oil temperature	0...70 °C*
Relative air humidity	max. 90 % (non-condensing)

\* The permissible temperature range is determined by the permissible viscosity range. For detailed information, ⇒ page 91, chapter 6.2

## 1.11 Emissions

The following emissions can occur during operation:

Emission	Corrective action / Note
Heat	Ensure fresh-air supply and warm-air extraction
Noise	Sound-proof the entrance to lift shaft (noise transmission)

## 2 Safety instructions

This documentation (manual) advises the user of the dangers and remaining risks that can arise even when the product is being used properly and for its intended purpose. It is essential to take note of the safety instructions in each section.

Signal words	Meaning
<b>DANGER!</b>	This denotes a directly imminent danger. If it is not attended to, it will result in death or serious injuries to people.
<b>WARNING!</b>	Denotes a potentially dangerous situation. If it is not prevented, it may result in death or serious injuries to people.
<b>CAUTION!</b>	Denotes a potentially dangerous situation. If it is not prevented, it may result in slight or minor injuries to people.
<b>ATTENTION!</b>	Denotes a potentially harmful situation. If it is not prevented, the product or its surroundings may be damaged.

### 3 Operating controls and indicators

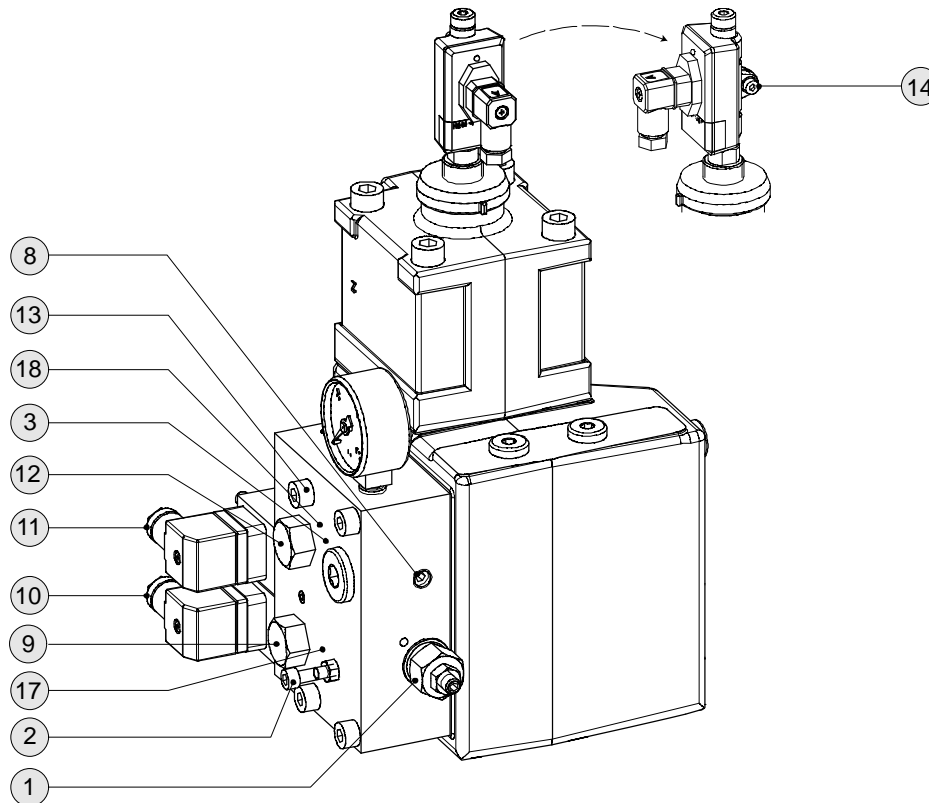

Illustration shows valve size 350, valve size 700 varies

Item	Description	Tools
1	Maximum-pressure setscrew	2 x open-ended spanner, 13 mm A/F
2	Bypass-pressure setscrew	Open-ended spanner, 10 mm A/F Allen key, 5 mm A/F
3	Lowering-speed limiter (valve size 700 only)	Open-ended spanner, 10 mm A/F Allen key, 5 mm A/F
8	Pressure gauge shut-off screw (valve sizes 175 and 350)/ Pressure gauge shut-off valve (valve size 700)	Allen key, 4 mm A/F —
9	Filter screw, UP	Open-ended spanner, 22 mm A/F
10	UP solenoid	Allen key, 3 mm A/F
11	DOWN solenoid	Allen key, 3 mm A/F
12	Filter screw, DOWN	Open-ended spanner, 22 mm A/F
13	Pilot plate	Allen key, 6 mm A/F
14	Adjusting/clamp screw for mech. zero point / Hall sensor	Allen key, 3 mm A/F
17	UP damping jet*	Allen key, 3 mm / 5 mm A/F
18	DOWN damping jet*	Allen key, 3 mm / 5 mm A/F

\* Accessible from the front side only for valve size 700; valve sizes 175 and 350 require removal of the pilot plate

### 3.1 Emergency-lowering valve (EN 81)



#### DANGER!

Car descent

Can lead to death or serious injuries.

Before operating the emergency-lowering valve, make sure that there are no people or materials in the lift shaft.

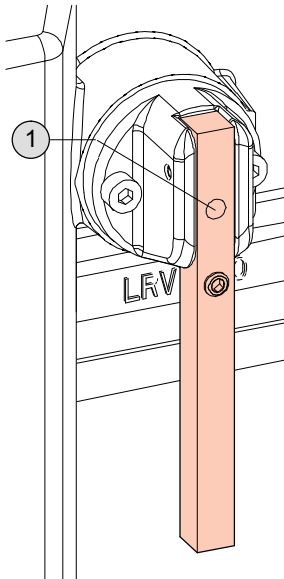

Pressing lever = lowering the car

The car is lowered by pressing the lever of the emergency-lowering valve.

Type VN:

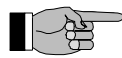

**IMPORTANT!:** The minimum preload pressure of 6 ... 10 bar remains (prevents slack-rope build-up as per EN 81).

#### Temporary deactivation of preload pressure

For the purpose of checks or maintenance the preload can be temporarily deactivated.

If no other M3-screw is ready to hand:

1. Remove the fastening screw from a solenoid plug
2. Screw the M3-screw into the opening (1) of the lever of the emergency-lowering valve

In order to deactivate the preload pressure:

3. Pull the M3-screw and simultaneously press the lever of the emergency-lowering valve
4. Undo the M3-screw from the lever of the emergency lowering

If the M3-screw had been undone from the solenoid plug:

5. Screw the M3-screw back into the solenoid plug

### 3.2 Display of the operating status



#### Legend for the LEDs

##### 1 RUN

Ready for operation (green). Lights when ready for travel; off during parameterisation

##### 2 UP

UP travel (yellow). Lights during upwards travel (fast and slow)

##### 3 DOWN

DOWN travel (yellow). Lights during downwards travel (fast and slow)

##### 4 ERROR

Fault indication (red). Lights when a fault has occurred; no travel is possible

##### 5 SIU-1

SIU-1 display (yellow). Lights when the permissible demand/feedback difference is exceeded

##### 6 RELAY

Relay display (yellow). Lights when the relay actuates because of a fault, ⇒ table on page 75

### 3.3 Miniterminal



#### Keys

- 1 Demand values menu
- 2 Options menu
- 3 Zero point display
- 4 Menu - Functions/Informations
- ↑ Steps to previous parameter
- ↓ Steps to next parameter
- + Increases the value of the current parameter
- Decreases the value of the current parameter
- E When parameter value is displayed:  
back to parameter selection;  
in parameter selection mode:  
quits parameterisation mode
- ↵ Pipe-rupture valve test

#### General description

- Commands are displayed during travel
- Zero-point adjustment
- Fault memory can be called up

### Display during travel

During travel the display indicates the status of the command inputs K1 ... K8.

For this purpose the command signals are displayed coded as powers of 2:

- K1 = 1
- K2 = 2
- K3 = 4
- K4 = 8
- K5 = 16
- K6 = 32
- K7 = 64
- K8 = 128

If several command signals are present simultaneously, e.g. K3 and K4, the display indicates the sum of the individual signals:

K3 = 4, K4 = 8, display = 012

With the command input set to Bucher K1..K8 (⇒ page 76) the following values will be displayed:

Travel command	Command signal	Additional command signals				
		none (normal travel) —	Inspection speed K5	Auxiliary speed		
				K6	K7	K8
none		0	16	32	64	128
Slow UP	K2	2	18	34	66	130
Fast UP	K1 + K2	3	19	35	67	131
Slow DOWN	K4	8	24	40	72	136
Fast DOWN	K3 + K4	12	28	44	76	140

### Description of function

- By pressing any of the keys 1 to 4 for at least 2 seconds, the DELCON switches into parameterisation mode. No travel is possible; the green RUN LED on the DELCON goes out.
- Select the desired parameter using the ↑ or ↓ key

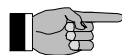

**IMPORTANT!:** The parameter names of the menu Options (2) do not appear in numeric order of sequence, but in the order of sequence as shown in the parameter overview, ⇒ page 67, chapter 5.2

- Display value with + or – key
- Increase value with + key, decrease value with – key
- With ↑ or ↓ key, save the value and return to parameter selection
- With key E, do not save the value and return to parameterisation mode
- Press the key E again to quit parameterisation mode
- If no key pressed within 5 minutes, the DELCON automatically quits parameterisation mode (changes to the currently displayed parameter are not saved)

### Display during parameterisation

- Parameter name e.g. P1.01 = Start speed UP
- P1.xx: Demand value parameters
- P2.xx: Options parameters
- d4.xx: Informations
- F4.xx: Error list
- Overview of parameters accessible with the Miniterminal ⇒ page 67, chapter 5.2
- Display of value of parameter, excluding name of unit, e.g. 6.85

### Fault code

- Fault memory for the last 8 faults
- For explanation of error codes ⇒ page 84, chapter 5.7.2

### Example for changing parameter value

#### Change parameter value "Inspection" (P2.06)

1. Press key 2 for approximately 2 seconds
    - ⇒ DELCON switches to the parameterisation mode
    - ⇒ green LED (RUN) on DELCON goes out
    - ⇒ travel not possible
  2. With the ↑ or ↓ key, select the parameter with display P2.06
    - ⇒ ↑ to switch to previous parameter display
    - ⇒ ↓ switch to next parameter display
  3. Press key + or – once
    - ⇒ the actual parameter value is displayed
  4. Press key + or – again until the desired numerical value is reached
    - ⇒ + parameter value is increased
    - ⇒ – parameter value is decreased
  5. Press key ↑ or ↓
    - ⇒ save desired parameter value
    - ⇒ return to parameter display P2.06
-  **IMPORTANT!:** With the E key, value changes NOT saved and return to last parameter display P2.06
6. With key ↑ or ↓, select the next parameter  
or  
with keys 1 ... 4, select a different menu
  7. Quit parameterisation mode with the E key
    - ⇒ green LED (RUN) on DELCON lights up
    - ⇒ travel possible

## 3.4 Handterminal



### Keys

- 1 Menu - Demand values
- 2 Menu - Options
- 3 Zero point display
- 4 Menu - Functions/Informations
- ↑ Steps to previous parameter
- ↓ Steps to next parameter
- + Increases the value of the current parameter
- Decreases the value of the current parameter

### General description

- Easy set-up of the travel curve
- Commands, feedback value and control voltage are displayed during travel
- Zero-point adjustment
- Fault memory can be called up

### Connection

- Connect the Handterminal to the DELCON using the cable provided
- Connecting cable is standard Ethernet network cable

### Description of function

- By pressing any of the keys 1 to 4, the DELCON switches into parameterisation mode. No travel is possible; the green RUN LED on the DELCON goes out.
- Select the desired parameter using the ↑ or ↓ key
- Increase value with + key, decrease value with – key
- With ↑ or ↓ key, save the value and return to parameter selection
- With keys 1, 2, 3 or 4, do not save the value, and return to parameterisation mode
- If no key pressed within 5 minutes, the DELCON automatically quits parameterisation mode (changes to the currently displayed parameter are not saved)

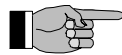

**IMPORTANT!:** In order to quit parameterisation mode:

- Either press keys  $\uparrow$  and  $\downarrow$  simultaneously (changes to the currently displayed parameter are saved)
- or
- unplug cable and wait for about 3 seconds (changes to the currently displayed parameter are NOT saved)

DELCON will return to RUN mode.

K1-K8	1100	0000
C: +3.45		F: +4.18

Fast speed	$\wedge$
	7.50 V

1) Err:SIU-1	
1x	51965 h

### Display during travel

- 1st line: status of command inputs K1 ... K8  
0: no command  
1: command is present
- 2nd line: existing control voltage (C) and feedback value (F) in volts

### Display during parameterisation

- 1st line: parameter name
- 2nd line: value of parameter, including unit

### Fault code

- 1st line: fault memory read-out, fault description
- 2nd line: total number of occurrences of this fault; last occurrence was at operating hours h
- For explanation of error codes  $\Rightarrow$  page 84, chapter 5.7.2

## 3.5 Password

The DELCON's parameters and functions can be password-protected. The password consists of four digits. Password "0000" means that password protection is not activated (this is the factory setting).

### Setting a password

1. Press the key 4

The display will read

Commands Information list
------------------------------

2. Press the key  $\uparrow$  several times until the display reads

Password + execute
-----------------------

3. Press the key +

If either no password has previously been set (i.e. password is "0000"), or a password is set and the user is currently logged in the display will read

+ change - log out
-----------------------

Continue with step 4

If the display reads  a password has already been set.

The user is currently not logged in.

Abort by pressing the keys ↑ and ↓ simultaneously.

In order to continue setting a password:

4. Press the key +

The display will read  with the first digit signaling.

5. Press the key + to increase  
or  
the key – to decrease the value of the signaling digit

6. Press the key ↓ to select the next digit  
or  
the key ↑ to select the previous digit

When all digits display the desired value, with the digit currently selected still signaling:

7. Press the keys ↑ and ↓ simultaneously to transmit the password.

The display will read  with the first digit signaling. The user is prompted to enter the password a second time for confirmation.

8. Enter the password again as described above, finish by pressing the keys ↑ and ↓ simultaneously

If the two passwords entered are identical, the DELCON will quit parameterisation mode.

The user is logged in, parameters can be changed.

In order to log out and protect the DELCON against inadvertent parameterisation: ⇒ Log out.

If the two passwords entered are different, the display will read

Confirmation  
not allowed

for approx. 1 second, then change to

Password  
0000

with the first digit signaling. The user is prompted to

repeat the complete password setting procedure.

### Logging in

---

1. Press the key 4

The display will read  .

---

2. Press the key ↑ several times until the display reads

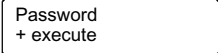

---

3. Press the key +
- 

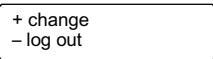
If the display reads  the user is either logged in already, or no password is set (i.e. password is "0000").

Press one of the keys 1 to 4 to continue in parameterisation mode or press the keys ↑ and ↓ simultaneously to quit parameterisation mode.

---

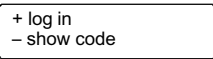
If the display reads  a password is set and the user is currently not logged in.

Continue with step 4.

---

4. Press the key +

The display will read  with the first digit signaling.

---

5. Press the key + to increase or the key – to decrease the value of the signaling digit
- 

6. Press the key ↓ to select the next digit  
or  
the key ↑ to select the previous digit
- 

When all digits display the desired value, with the digit currently selected still flashing:

7. Press the keys ↑ and ↓ simultaneously to transmit the password
- 

If the password entered is correct, the DELCON will quit parameterisation mode.

The user is logged in, parameters can be changed.

---

If the password entered is incorrect, the display will read

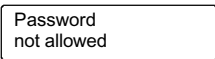
 for approx. 1 second, then the DELCON will quit parameterisation mode.

In order to try again, start over by pressing key 4.

In order to retrieve a forgotten password: ⇒ Forgotten password.

---

## Logging out



**IMPORTANT!** The DELCON features a counter, that logs out the user automatically after 8 hours. The proper function of the counter requires, however, that the power supply to the DELCON will NOT be disrupted. Disruption of the power supply causes the counter to start over, while keeping the user logged in.

In order to log out manually:

1. Press the key 4

The display will read

Commands  
Information list

2. Press the key  $\uparrow$  several times until the display reads

Password  
+ execute

3. Press the key +

The display will read

+ change  
- log out

4. Press the key –

The DELCON will quit parameterisation mode.

If an attempt is made to change a parameter while the user is logged out, the display will read

*parameter name*  
not allowed

Abort by pressing the keys  $\uparrow$  and  $\downarrow$  simultaneously.

## Forgotten password

1. Press the key 4

The display will read

Commands  
Information list

2. Press the key  $\uparrow$  several times until the display reads

Password  
+ execute

3. Press the key +

If the display reads

+ change  
- log out

the user is either logged in already, or no password is set (i.e. password is "0000").

Abort by pressing the keys  $\uparrow$  and  $\downarrow$  simultaneously.

If the display reads

+ log in  
- show code

a password is set and the user is currently not logged in.

Continue with step 4

4. Press the key –

The display will read

Code  
*code number*

5. Report the code number to the Bucher customer service in order to obtain the valid password

---

6. Log in with the valid password: ⇒ Log in  
or  
abort by pressing the keys ↑ and ↓ simultaneously

---

### 3.6 WinDelta32 - PC program

Software, RS232-adapter and cable can be ordered as part no. 3007010867+

RS232-USB converter can be ordered as part no. 3007014722

The software can be downloaded free of charge from:

<http://www.bucherhydraulics.com>

#### Parameterisation

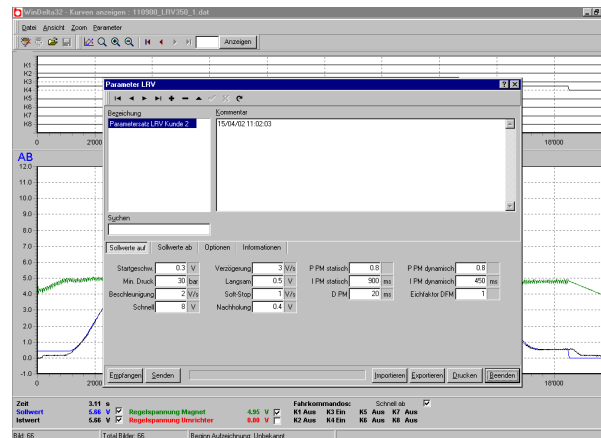

- DELCON parameters can be read off and set via PC
- Parameter sets can be saved
- Comments can be added to parameter sets
- Print function

#### Display of curves

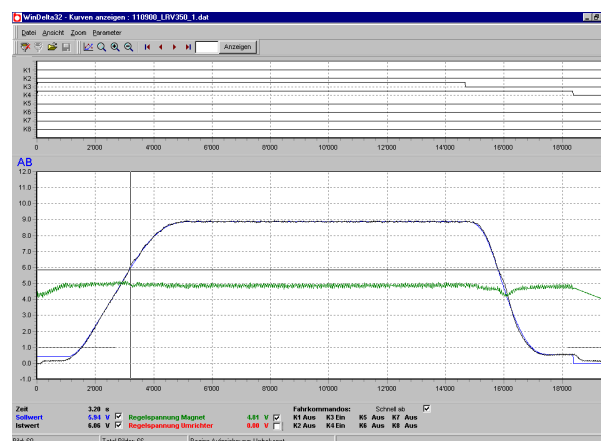

- Curves (demand signal / feedback value / control voltage) displayed in real time
- Display of commands K1 ... K8
- Zoom function / Print function

## 4 Installation and commissioning

### 4.1 Installation

#### Orientation of the ball-valve outlet

As standard, the ball-valve outlet is rear-facing (code H)

Alteration to left (L) or right (R) is possible.



**IMPORTANT!** The ball-valve outlet must not be turned to a new position unless the hose is first disconnected.

#### Reorienting the ball-valve outlet

---

7. Unscrew cap screws on head of valve

---

8. Remove the screws

---

#### WARNING!

**Risk of damage to the flow-rate measuring system**

When orienting the ball-valve outlet, **never** lift up the head of the valve.

---

9. Turn head of valve to desired ball-valve position

---

10. Insert the cap screws and tighten them

- | Tightening torque for    LRV 175-1 = 25 Nm
- LRV 350-1 = 50 Nm
- LRV 700-1 = 80 Nm

---

11. Check the mechanical zero point

- | Readjustment may be necessary (⇒ page 60, chapter 4.3.9)

---

**The ball-valve outlet is now correctly oriented**

## 4.2 Assembly

### 4.2.1 Hose or pipe



#### CAUTION!

##### Contamination in the line

Contamination adversely affects the valve's function. This can lead to a dangerous system condition.

Preventive measures:

- Clean the hose or pipe before fitting it
  - Leave sealing caps/plugs in place until assembly
  - Check that all fittings are assembled correctly
- 
- Do not twist the hoses
  - Do not mount hoses under tensile strain
  - Observe minimum bending radii
  - Protect hoses against mechanical damage (e.g. from sharp edges)
  - Support hoses with hose clamps (approx. 1.5 m away from valve)

## 4.2.2 Power supply unit



### DANGER!

#### Dangerous voltage

Can lead to death or serious injuries.

Before fitting the power supply unit, disconnect all power to the control cabinet.

- The NTA-2 power supply unit is intended for installation in the control cabinet
- There must be no voltage at the power supply unit when working on its connections or exchanging the DELCON

Feedback cable connection  
⇒ page 32

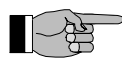

**IMPORTANT!:** Set jumper JP2 to earth the reference potential of the command inputs (observe the note on page 28).

### Screwless terminals

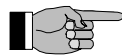

**IMPORTANT!:** To prevent damage, the NTA-2 must only be wired when the DELCON card has been removed.

Command signals

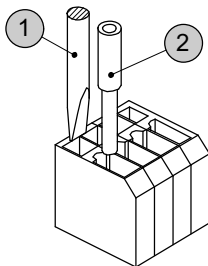

Feedback cable plug

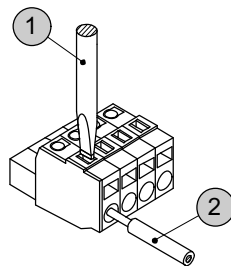

- Only one core per terminal point (if necessary, combine two cores in a terminating sleeve)
- Use a size 0 screwdriver (2.5 mm)
- Insert a screwdriver (1) as far as the stop
- Open the clamp spring by gently pressing down or turning the screwdriver, and insert the core (2) into the terminal point
- Remove the screwdriver - the conductor is now safely clamped

4.2.3 Wiring the power supply unit

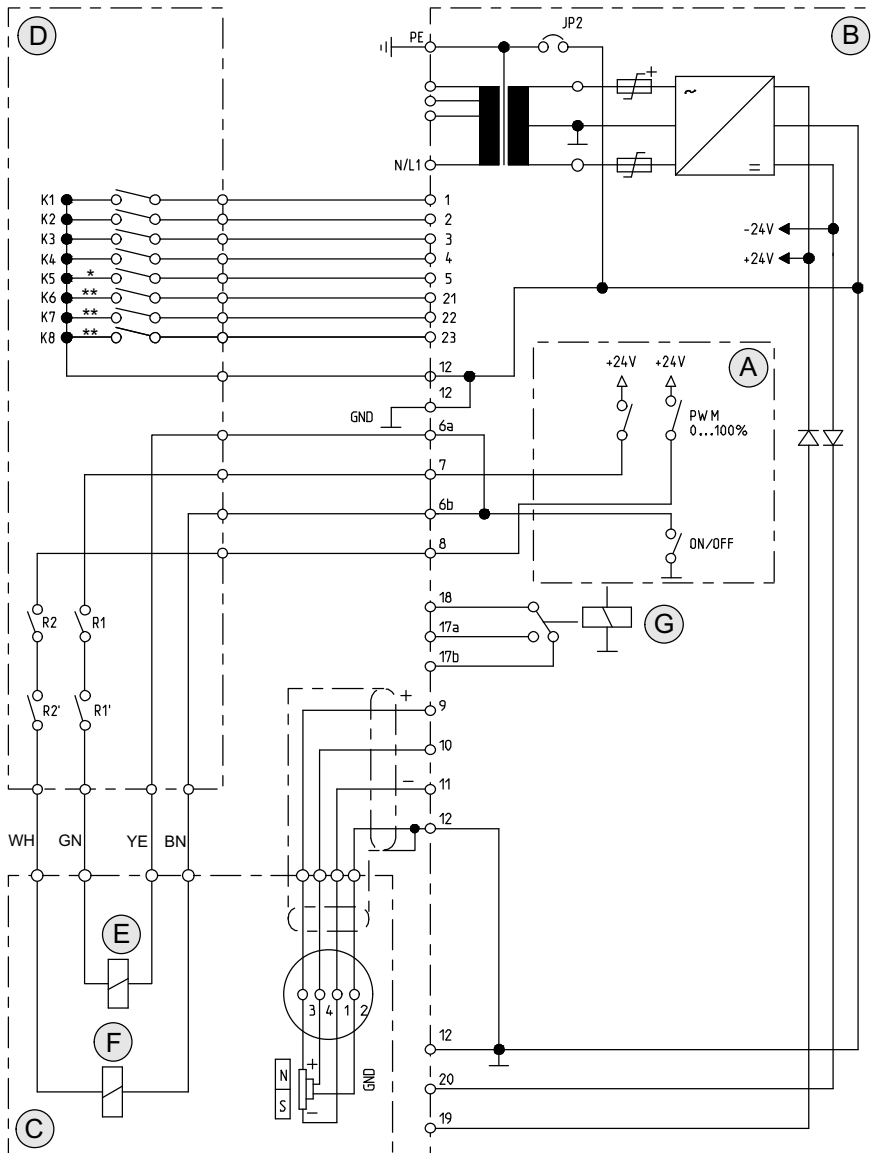

- Legend**
- 1 Fast UP
  - 2 Slow UP
  - 3 Fast DOWN
  - 4 Slow DOWN
  - 5 Inspection speed
  - 21 Auxiliary speed
  - 22 Auxiliary speed
  - 23 Auxiliary speed
  - 12 Reference potential
  - 6a/6b Common
  - 7 DOWN solenoid
  - 8 UP solenoid
  - 9 Stabilised voltage supply +15 V
  - 10 Feedback signal (input)
  - 11 Stabilised voltage supply -15 V
  - 12 GND, test/measurement
  - 20 -24 V emergency power supply
  - 19 +24 V emergency power supply
  - YE yellow
  - GN green
  - BN brown
  - WH white

\* When the additional command K5 is present, the DELCON's two "fast" speeds drop to a preset percentage of their nominal values. The setting is adjustable between 20 ... 80 %.

\*\* When the additional command K6, K7 or K8 is present, the DELCON's two "fast" speeds drop to a preset percentage of their nominal values. The settings are adjustable between 20 ... 100 %.

K1 ... K8, potential-free contacts or semiconductors

R1+R2 as per EN 81

<b>Legend</b>	A	DELCON	E	DOWN solenoid
	B	NTA-2	F	UP solenoid
	C	LRV-1	G	Relay for the monitoring of the demand feedback deviation or the speed in the unlocking zone
	D	Control cabinet (customer's)		

## 4.2.4 Electrical emergency-lowering 2 x 24 VDC

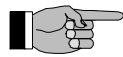

**IMPORTANT!** The operator must undertake any further measures required to ensure short-circuit and overvoltage protection.

If a mains (line) failure occurs, the power supply unit can be powered by an external battery supply (2 x 24 V) through terminals 12, 19 and 20.

- Relay  $R_N$  drops out when there is a power failure and the two normally-closed relays connect to the battery
  - Inputs 19 and 20 have diode-protection from polarity reversal or feedback to the battery
- The lift can be lowered to a predefined stopping position by means of "Slow DOWN" or auxiliary speed K6 ... K8 (travel signals are generated by the lift control system or by a push-button switch)

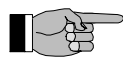

**IMPORTANT!** only possible with 2 x 24 V (or 4 x 12 V) batteries

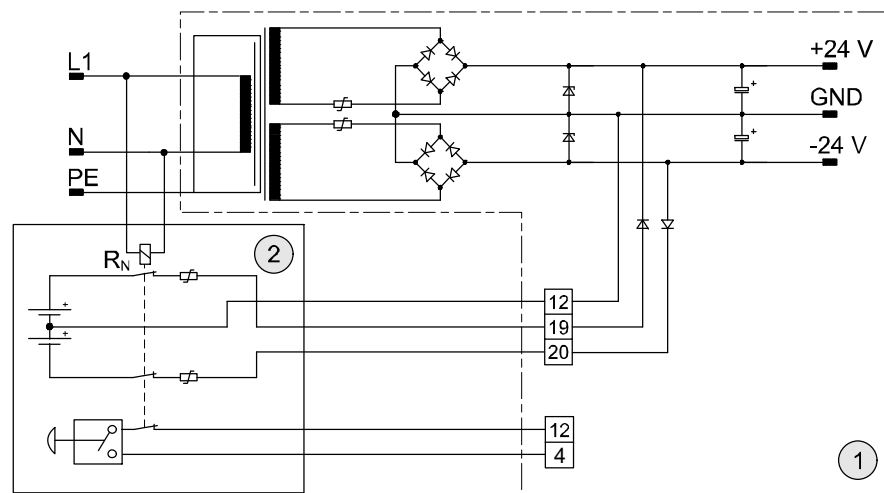

Slow DOWN

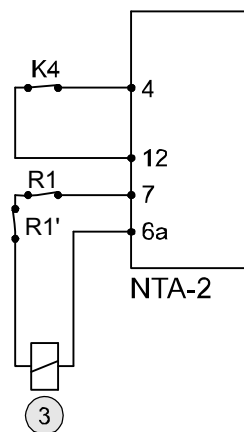

Auxiliary speed

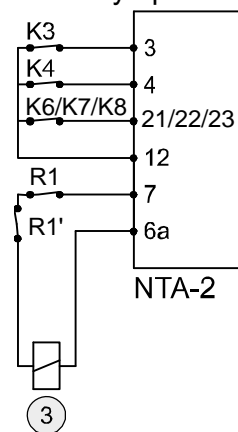

Legend

1	NTA-2 power supply unit
2	Supplied by customer
3	DOWN solenoid



## 4.3 Commissioning/settings

### 4.3.1 Checking the check numbers

- The valve check number is stamped on the body (below the manual pump) ⇒ page 9, chapter 1.5.2
- DELCON check number: ⇒ page 21, chapter 1.7, item 7

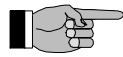

**IMPORTANT!** Always quote the check number when making enquiries. This makes it easier for the factory to help you!

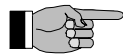

**IMPORTANT!** The check numbers on the DELCON and the valve must be the same to avoid the need for resetting.

### 4.3.2 Checking the minimum static pressure

To check the minimum static pressure (with empty car):

1. Make sure that the pressure gauge shut-off screw/ shut-off valve is undone (the pressure gauge indicates changing pressures in the lift system without delay)
2. Read the minimum static pressure on the pressure gauge
3. Compare minimum static pressure on rating plate with actual minimum static system pressure on the pressure gauge  
| ⇒page 9, chapter 1.5.1, item (7)
4. If the difference is more than 5 bar, but less than 10 bar:  
set the bypass pressure again (⇒page 53, chapter 4.3.3) and decrease or increase the maximum operating pressure resp. by the amount of the difference (⇒page 56, chapter 4.3.4)  
| Bypass pressure too high: car travels past landing  
| Bypass pressure too low: UP starting jolt
5. If the difference is more than 10 bar:  
contact the customer service

The minimum static pressure shown is correct

### 4.3.3 Bypass pressure setting

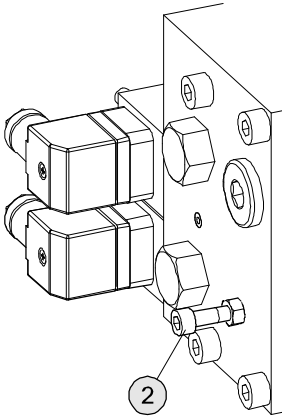

#### Setting the bypass pressure with the Handterminal or Miniterminal

1. Make sure that the car is empty
2. Slacken the locknut for bypass-pressure setscrew (2)
3. Unscrew bypass-pressure setscrew (2) approx. 2 turns counter-clockwise

If the Handterminal is being used:

4. Connect the Handterminal to the DELCON
5. Press key 3 on Handterminal or Miniterminal => zero point or feedback value will be displayed, monitoring of demand/feedback-difference (SIU-1) and speed in the unlocking zone (SIU-4) are disabled
6. Send UP command
7. With motor running, slowly turn bypass-pressure setscrew (2) clockwise until feedback value rises (visible on the display), until the car moves or until the beep tone sounds
8. Turn bypass-pressure setscrew (2) back by half a turn counter-clockwise
9. Tighten the locknut for bypass-pressure setscrew (2)
10. Cancel the UP command

If the Handterminal is being used:

11. Disconnect the Handterminal from the DELCON

If the Miniterminal is being used:

12. Press the key E
13. Overwrite the value of the min. static pressure given on the nameplate (=> page 9, chapter 1.5.1, Item (7)) with the actual value

**The bypass pressure is now set**

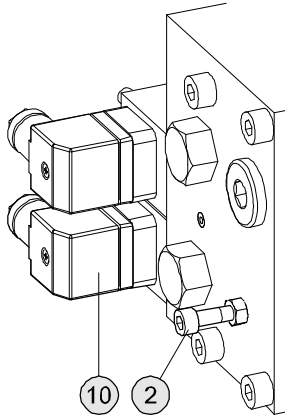
**Setting the bypass pressure with the pressure gauge, without Handterminal**

1. Make sure that the car is empty
2. Make sure that the pressure gauge shut-off screw/ shut-off valve is undone (the pressure gauge indicates changing pressures in the lift system without delay)
3. Read the minimum static pressure on the pressure gauge
4. Close the ball valve
5. Press emergency-lowering lever (vents pressure in the valve)  
| ⇒ page 35, chapter 3.1
6. Bridge the two terminals of the relay output connected to the lift control system (either 17a, 18 or 17b, 18 – depending on the configuration of the relay output, ⇒ page 26, chapter 1.8.1)
7. Remove the UP solenoid plug (10)
8. Slacken the locknut for bypass-pressure setscrew (2)
9. Unscrew bypass-pressure setscrew (2) approx. 2 turns counter-clockwise
10. Send UP command
11. With motor running, slowly turn bypass-pressure setscrew (2) clockwise until pressure is approx. 3 bar below the min. static pressure previously read
12. Tighten the locknut for bypass-pressure setscrew (2)
13. Cancel the UP command
14. Remove the bridge from the terminals of the relay output
15. Refit the UP solenoid plug (10)
16. Open the ball valve
17. Overwrite the value of the min. static pressure given on the nameplate (⇒ page 9, chapter 1.5.1, Item (7)) with the actual value

**The bypass pressure is now set**

### Setting the bypass pressure with the car in sight, with or without Handterminal

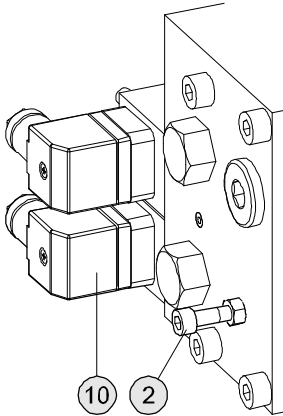

1. Make sure that the car is empty

Only if the setting is performed WITHOUT Handterminal:

2. Bridge the two terminals of the relay output connected to the lift control system (either 17a, 18 or 17b, 18 – depending on the configuration of the relay output, ⇒ page 26, chapter 1.8.1)

Only if the setting is performed WITHOUT Handterminal:

3. Remove the UP solenoid plug (10)
4. Slacken the locknut for bypass-pressure setscrew (2)
5. Unscrew bypass-pressure setscrew (2) approx. 2 turns counter-clockwise

Only if the setting is performed WITH Handterminal:

6. Connect the Handterminal to the DELCON and press key 3 on Handterminal => zero point or feedback value will be displayed, triggering of the UP-valve is disabled, monitoring of demand/feedback-difference (SIU-1) and speed in the unlocking zone (SIU-4) are disabled

7. Send UP command

8. With motor running, slowly turn bypass-pressure setscrew (2) clockwise until the car moves

9. Turn bypass-pressure setscrew (2) half a turn counterclockwise

10. Tighten the locknut for bypass-pressure setscrew (2)

11. Cancel the UP command

Only if the setting is performed WITH Handterminal:

12. Disconnect the Handterminal from the DELCON

Only if the setting is performed WITHOUT Handterminal:

13. Remove the bridge from the terminals of the relay output

Only if the setting is performed WITHOUT Handterminal:

14. Refit the UP solenoid plug (10)

15. Overwrite the value of the min. static pressure given on the nameplate (⇒ page 9, chapter 1.5.1, Item (7)) with the actual value

The bypass pressure is now set

#### 4.3.4 Setting the maximum operating pressure (EN 81)

##### Adjusting the maximum pressure

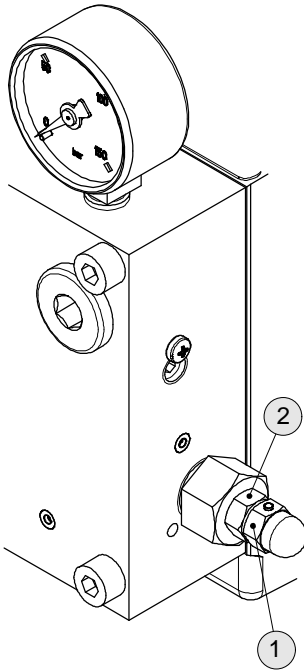

1. Make sure that the pressure gauge shut-off screw is open (the pressure gauge indicates changing pressures in the lift system without any delay)
2. Slacken the locknut (2)
3. Turn cap nut (1) approx. 2 turns counterclockwise
4. Bypass the overload pressure switch (DZ)
5. Press emergency-lowering lever until a relevelling is triggered and close the ball valve immediately (before the relevelling is completed)
6. Turn cap nut (1) slowly clockwise until calculated pressure is reached
7. Tighten locknut (2)
8. Open the ball valve
9. Remove the bypass from the overload pressure switch (DZ)
10. Overwrite the value of the max. operating pressure given on the nameplate (⇒ page 9, chapter 1.5.1, item (10)) with the new value

**The maximum pressure has been adjusted for the new situation**

#### 4.3.5 Setting the demand/feedback response difference, SIU-1

The SIU-1 function monitors the deviation of the actual travel curve from the demand travel curve.

- If the permissible deviation is exceeded the DELCON electronic card automatically triggers an emergency stop. The LEDs ERROR and SIU-1 on the DELCON light up.
- Provided that the parameters "SIU type" and "Relay function" are set accordingly (⇒ table on page 75), the relay actuates (terminals 17a/b and 18). The actuation of the relay can be evaluated by the lift control.
- The deviation from the demand speed which will trigger a SIU-1 ("SIU-1 difference") can be set with the Handterminal, Miniterminal or PC software

#### 4.3.6 Setting the speed-monitoring in the unlocking zone of the door, SIU-4

The SIU-4 function monitors the speed during levelling, releveling and anti creeping. Depending on the settings of "SIU type" and "Relay function" (⇒ table on page 75), the relay actuates (terminals 17a/b and 18). The switching of the relay can be evaluated by the lift control system in order to prevent the opening of the doors if the max. permissible speed (acc. to EN 81: 0.3 m/s) is exceeded.

- The speed which will trigger a SIU-4 ("SIU-4 threshold") can be set with the Handterminal, the Miniterminal or PC software

#### 4.3.7 Setting the inspection-travel speed

To set the inspection travel speed, see the Options menu ⇒ page 71, chapter 5.5.2, parameter "Inspection speed".

### 4.3.8 Positioning the shaft switches for the deceleration distance

The spacing of the shaft switches depends on the car speed  
⇒ next page

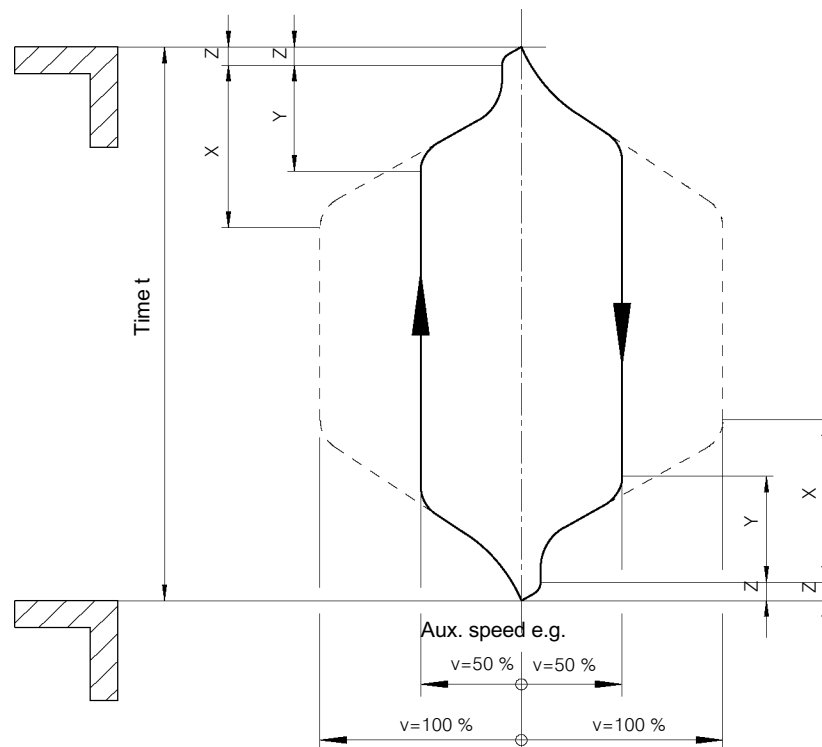

- X Deceleration distance (shaft switches) for maximum speed
- Y Deceleration distance (shaft switches) for auxiliary speed (for example, 50 % of maximum speed; adjustable in DELCON from 20 ... 100 %)
- Z Stop-switch before landing (20 ... 30 mm) (soft-stop adjustment is carried out at the DELCON)

**Required deceleration distance**

Guidelines for positioning the deceleration switches.

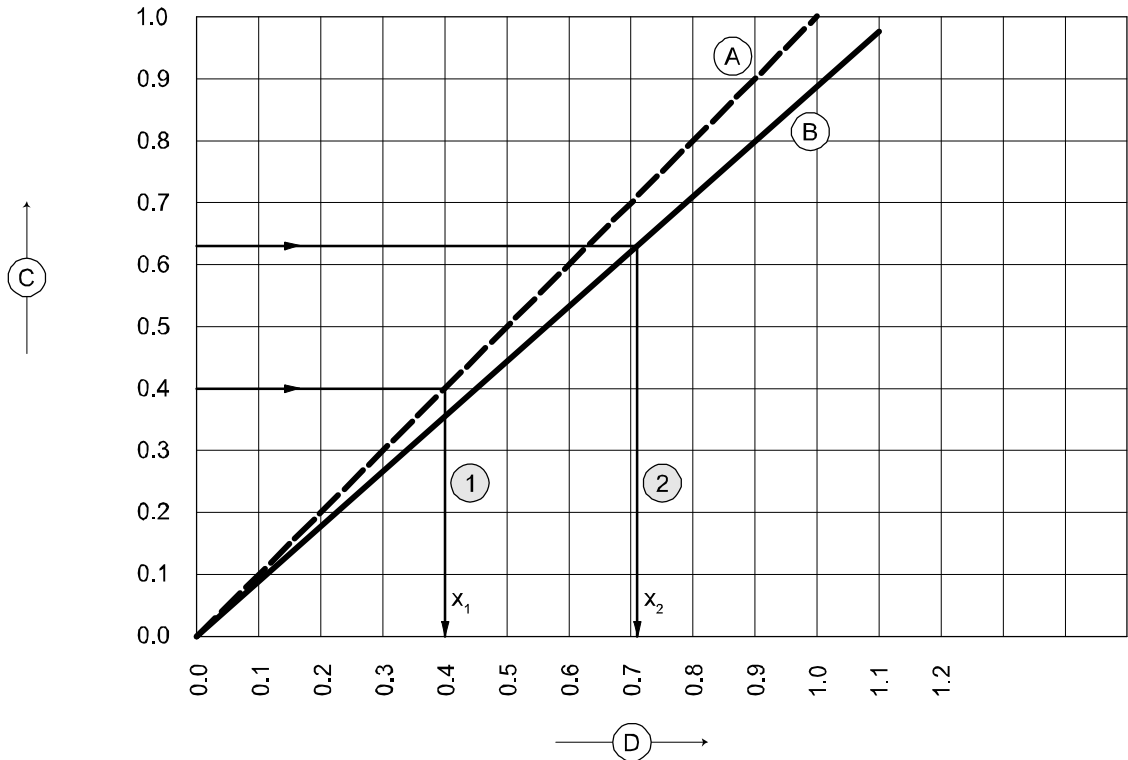

Examples	1	Deceleration distance "X" for direct (1:1) drive e.g.: $v = 0.4 \text{ m/s} \rightarrow x_1 = 0.4 \text{ m}$
	2	Deceleration distance "X" for indirect (2:1) drive e.g.: $v = 0.63 \text{ m/s} \rightarrow x_2 = 0.71 \text{ m}$
Legend	A	Direct drive (1:1)
	B	Indirect drive (2:1)
	C	Car speed [m/s]
	D	Distance of deceleration switches before landing [m]

### 4.3.9 Setting the mechanical zero point

With Handterminal, =>  
page 39, chapter 3.4

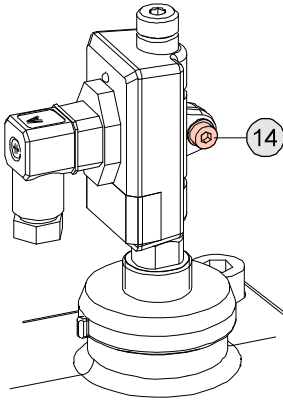

The zero point is factory-set.

This can be checked with the Handterminal, Miniterminal or PC. If, on commissioning, the reading is outside the range  $\pm 0.05V$ , then the zero point must be reset.

#### Setting the zero point

1. Close the ball valve

If the Handterminal is being used:

2. Connect the Handterminal to the DELCON and press key 3 on Handterminal => zero point or feedback value will be displayed

If the Miniterminal is being used:

3. Press key 3 on Miniterminal

4. Using a 3 mm Allen key, slacken the adjusting/clamp screw (14) a little

5. Remove Allen key (it has a magnetic influence)

6. Hold the feedback sensor by the plug and move it axially until the feedback reading is less than  $\pm 0.05 V$

7. Tighten adjusting/clamp screw (14)

If the Handterminal is being used:

8. Return to RUN mode by pressing the  $\uparrow$  and  $\downarrow$  keys on the Handterminal simultaneously

If the Miniterminal is being used:

9. Return to RUN mode by pressing the E key on the Miniterminal

10. Open the ball valve

The zero point is now correctly set

#### Checking zero point after maintenance work

The error memory of the DELCON should be checked each time maintenance work is carried out. If there is a warning with regard to zero point deviation or, if the actual value for the zero point is outside the range  $\pm 0.05 V$ , then the zero point has to be reset.

### 4.3.10 Pilot filters

Filter-strainers are positioned upstream of the lowering and lifting valves in accordance with the international standards for lifts (EN 81.2 art. 12.5.7). The filters are easily accessible from outside the valve.



#### CAUTION!

##### Contamination in valve (filter)

Severe malfunction possible. People may suffer injury and materials may be damaged.

Never operate the lift without the pilot filter installed.

Carry out regular maintenance as per maintenance plan  
 ⇒ page 90, chapter 6.1

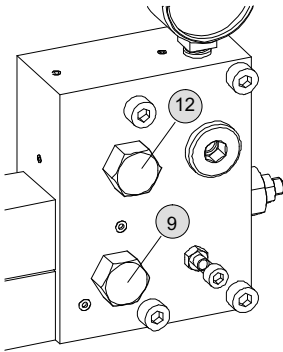

#### Cleaning the pilot filters (9, 12)

1. Switch main switch OFF
2. Close the ball valve
3. Press emergency-lowering lever (vents pressure in the valve)  
 | the pressure in the valve is vented
4. Unscrew the filter screw  
 | with a 22 A/F open-ended spanner
5. Remove filter
6. Clean in the proper manner or exchange the filter
7. Insert the filter
8. Screw in the filter screw
9. Open the ball valve
10. Switch main switch ON

The pilot filters are now clean

### 4.3.11 Pipe rupture valve test

A precondition for testing the pipe-rupture valve is that the lift must be working properly, without any faults.



#### DANGER!

Uncontrolled descent (free fall).

Leads to death or serious injuries.

Before testing the pipe-rupture valve, make sure that there are no people or materials in the lift shaft.

#### Preparing to test the pipe rupture valve

1. Load the car to half of its rated capacity
2. Drive the car to the top floor

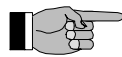

**IMPORTANT!:** Do not carry out the test if the car is too close to the lowest floor.

3. Prepare the Handterminal

#### Test of pipe rupture valve is prepared

Testing the pipe-rupture valve (for DELCON software version 2.110 or higher, with Handterminal or Miniterminal)

#### ATTENTION!

Uncontrolled descent (free fall)

Can cause damage to the support frame and car.

The elevator car must come to rest within 3 ... 5 metres.

If it does not, immediately release the + -key of the Handterminal  
↵ -key of the Miniterminal.

Resolve the problem and repeat the test.

If the Handterminal is being used:

1. On the Handterminal, select the "Pipe rupture" function in the Information (4) menu under "Commands"

If the Miniterminal is being used:

1. Continue with step 3

If the Handterminal is being used:

2. Press and hold the + key on the Handterminal; the DOWN LED on the DELCON will start to flash

If the Miniterminal is being used:

3. Press and hold the ↵ key on the Miniterminal; the DOWN LED on the DELCON will start to flash

- 
4. Send DOWN command

---

  5. Wait until the car is accelerating

---

  6. When the triggering speed is reached, the pipe rupture valve closes and travel stops

If the Handterminal is being used:

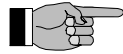

**IMPORTANT!:** Releasing the + key on the Handterminal stops the travel, and the maximum feedback value is displayed. If the DOWN command is still present on quitting the menu, travel will resume normally.

If the Miniterminal is being used:

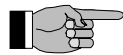

**IMPORTANT!:** Releasing the ↓ key on the Miniterminal stops the travel, and the maximum feedback value is displayed. If the DOWN command is still present on quitting the menu, travel will resume normally.

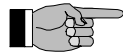

**IMPORTANT!:** Pipe rupture valves do not close completely leakage free.

In case of a simulated pipe rupture, as described in this test procedure, the leakage causes the pipe between the pipe rupture valve and the lift control valve to assume the same pressure as the hydraulic cylinder after a certain time.

This pressure compensation causes the automatic reopening of the pipe rupture valve.

This does not impede the safe function of the pipe rupture valve in case of an actual pipe rupture, since in case of an actual pipe rupture the pipe between the rupture valve and the lift control valve would remain without pressure, and the pressure compensation would therefore not occur.

If the pipe rupture valve is meant to remain closed after the test, the pipe between the rupture valve and the lift control valve must remain pressure-less, e.g. by continuous pressing of the manual emergency lowering valve.

---

#### The pipe-rupture valve has been successfully tested

---

7. In order to reopen the pipe rupture valve and make the lift ready for service: build up pressure using the hand pump or carry out an UP travel

---

The system is once again ready for use

Testing the pipe-rupture valve (up to DELCON software version 2.100)



**DANGER!**

**Uncontrolled descent (free fall)**

Leads to death or serious injuries.

Before testing the pipe-rupture valve, make sure that there are no people or materials in the lift shaft.

**ATTENTION!**

**Uncontrolled descent (free fall)**

Can cause damage to the support frame and car.

The elevator car must come to rest within 3 ... 5 metres.

If it does not, immediately switch off the main switch for the lift control system.

Resolve the problem and repeat the test.

1. Make a note of the existing setting of the "SIU Type" parameter in the DELCON  
| ⇒ page 71 ff., chapter 5.5.2
2. Set the "SIU Type" parameter in the DELCON to "Off"  
| If the Miniterminal is being used: Off = 4
3. Make a note of the existing setting of the "Demand val. red." parameter in the DELCON
4. Set the "Demand val. red." parameter in the DELCON to "Off"  
| If the Miniterminal is being used: Off = 1
5. Send a DOWN command to the controller
6. Wait until the car is accelerating
7. Remove the feedback plug (25) from the Hall sensor
8. When the triggering speed is reached, the pipe rupture valve closes and travel stops

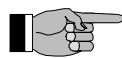
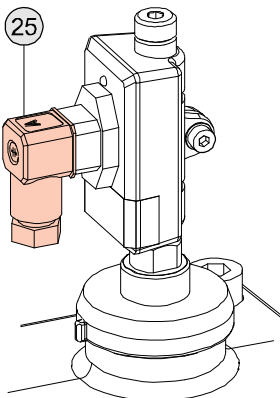

**IMPORTANT!** Pipe rupture valves do not close completely leakage free.

In case of a simulated pipe rupture, as described in this test procedure, the leakage causes the pipe between the pipe rupture valve and the lift control valve to assume the same pressure as the hydraulic cylinder after a certain time.

This pressure compensation causes the automatic reopening of the pipe rupture valve.

This does not impede the safe function of the pipe rupture valve in case of an actual pipe rupture, since in case of an actual pipe rupture the pipe between the rupture valve and the lift control valve would remain without pressure, and the pressure compensation would therefore not occur.

If the pipe rupture valve is meant to remain closed after the test, the pipe between the rupture valve and the lift control valve must remain pressure-less, e.g. by continuous pressing of the manual emergency lowering valve.

---

**The pipe-rupture valve has been successfully tested**

---

9. Cancel the DOWN command

---

10. Refit the feedback plug (25) to the Hall sensor

---

11. Reset the "SIU Type" parameter in the DELCON to the setting noted down (⇒ step 1.)

---

12. Reset the "Demand val. red" parameter in the DELCON to the setting noted down (⇒ step 3.)

---

13. In order to reopen the pipe rupture valve and make the lift ready for service: build up pressure using the hand pump or carry out an UP travel

---

## 5 Operation

### 5.1 Parameterisation with Handterminal

Demand values ⇒ 5.5.1	Options ⇒ 5.5.2	Hall sensor ⇒ 5.5.3	Information ⇒ 5.5.4
<b>1</b>	<b>2</b>	<b>3</b>	<b>4</b>
↑ Demand value up ↓ Demand value dn			↑ Commands ↓ Information list
<ul style="list-style-type: none"> <li>- Start speed</li> <li>- Min. pressure</li> <li>- Acceleration</li> <li>- Fast speed</li> <li>- Deceleration</li> <li>- Slow speed</li> <li>- Soft-Stop</li> <li>- Releveling</li> <li>- P sol. static</li> <li>- I sol. static</li> <li>- D sol.</li> <li>- P sol. dynamic</li> <li>- I sol. dynamic</li> <li>- Calibr. factor</li> </ul>	<ul style="list-style-type: none"> <li>- Start speed</li> <li>- Offset sol.</li> <li>- Acceleration</li> <li>- Fast speed</li> <li>- Deceleration</li> <li>- Slow speed</li> <li>- Soft-Stop</li> <li>- Releveling</li> <li>- P sol. static</li> <li>- I sol. static</li> <li>- D sol.</li> <li>- P sol. dynamic</li> <li>- I sol. dynamic</li> <li>- Calibr. factor</li> </ul>	<ul style="list-style-type: none"> <li>- Valve type</li> <li>- SIU type</li> <li>- SIU-1 difference</li> <li>- SIU-4 threshold</li> <li>- Accel.inspection</li> <li>- Inspection speed</li> <li>- Decel.inspection</li> <li>- K6 acceleration</li> <li>- K6 speed</li> <li>- K6 deceleration</li> <li>- K7 acceleration</li> <li>- K7 speed</li> <li>- K7 deceleration</li> <li>- K8 acceleration</li> <li>- K8 speed</li> <li>- K8 deceleration</li> <li>- Decel. emergency</li> <li>- Pulsation sol.</li> <li>- Demand val. red.</li> <li>- Start delay</li> <li>- Relay function</li> <li>- Command input</li> <li>- Auxiliary curve</li> <li>- Edge detection</li> </ul>	<ul style="list-style-type: none"> <li>- Zero point</li> </ul>
			<ul style="list-style-type: none"> <li>- Language/Sprache</li> <li>- Load parameter</li> <li>- Save parameter</li> <li>- Password</li> <li>- Delete errors</li> <li>- Pipe rupture</li> </ul>
			<ul style="list-style-type: none"> <li>- 1) Error</li> <li>- 2) Error</li> <li>- 3) Error</li> <li>- 4) Error</li> <li>- 5) Error</li> <li>- 6) Error</li> <li>- 7) Error</li> <li>- 8) Error</li> <li>- Software version</li> <li>- Hardware version</li> <li>- Serial number</li> <li>- Check number</li> <li>- Power on</li> <li>- Drive up</li> <li>- Drive down</li> <li>- Operation hour</li> <li>- + unstab voltage</li> <li>- - unstab voltage</li> </ul>

## 5.2 Parameterisation with Minterminal

<b>① Demand values</b> ⇒ 5.5.1	<b>② Options</b> ⇒ 5.5.2	<b>③ Hall sensor</b> ⇒ 5.5.3	<b>④ Information</b> ⇒ 5.5.4
<ul style="list-style-type: none"> <li>- P1.01 Start speed ↑</li> <li>- P1.02 Min. pressure ↑</li> <li>- P1.04 Acceleration ↑</li> <li>- P1.05 Fast speed ↑</li> <li>- P1.06 Deceleration ↑</li> <li>- P1.07 Slow speed ↑</li> <li>- P1.08 Soft-Stop ↑</li> <li>- P1.09 Relevelling ↑</li> <li>- P1.11 Start speed ↓</li> <li>- P1.12 Offset sol. ↓</li> <li>- P1.14 Acceleration ↓</li> <li>- P1.17 Fast speed ↓</li> <li>- P1.18 Deceleration ↓</li> <li>- P1.20 Slow speed ↓</li> <li>- P1.21 Soft-Stop ↓</li> <li>- P1.22 Relevelling ↓</li> </ul>	<ul style="list-style-type: none"> <li>- P2.01 Valve type</li> <li>- P2.03 SIU type</li> <li>- P2.04 SIU-1 difference</li> <li>- P2.05 SIU-4 threshold</li> <li>- P2.16 Accel.inspection</li> <li>- P2.06 Inspection speed</li> <li>- P2.07 Decel.inspection</li> <li>- P2.18 K6 acceleration</li> <li>- P2.08 K6 speed</li> <li>- P2.09 K6 deceleration</li> <li>- P2.20 K7 acceleration</li> <li>- P2.10 K7 speed</li> <li>- P2.11 K7 deceleration</li> <li>- P2.22 K8 acceleration</li> <li>- P2.12 K8 speed</li> <li>- P2.13 K8 deceleration</li> <li>- P2.14 Decel. emergency</li> <li>- P2.15 Pulsation sol.</li> <li>- P2.24 Demand val. red.</li> <li>- P2.25 Start delay</li> <li>- P2.26 Relay function</li> <li>- P2.27 Command input</li> <li>- P2.28 Auxiliary curve</li> <li>- P2.29 Edge detection</li> </ul>	<ul style="list-style-type: none"> <li>- Zero point</li> </ul>	<ul style="list-style-type: none"> <li>- F4.01 1) Error</li> <li>- F4.02 2) Error</li> <li>- F4.03 3) Error</li> <li>- F4.04 4) Error</li> <li>- F4.05 5) Error</li> <li>- F4.06 6) Error</li> <li>- F4.07 7) Error</li> <li>- F4.08 8) Error</li> <li>- d4.01 Software version</li> <li>- d4.02 Hardware version</li> </ul>

### 5.3 Overview of travel curve parameters

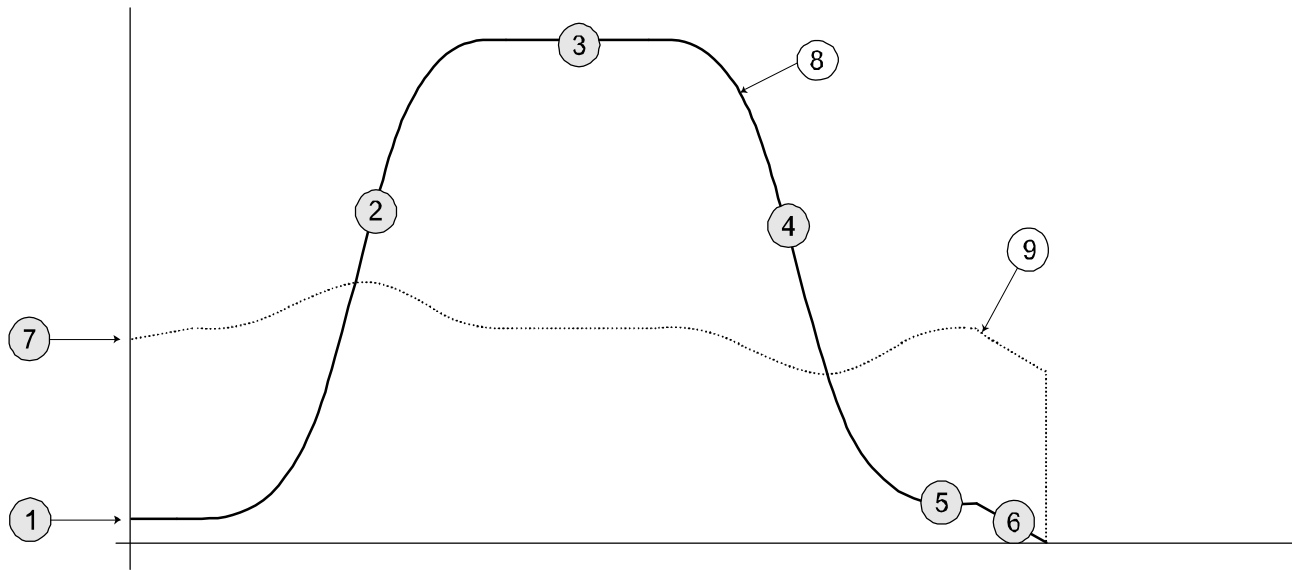

Legend	1	Start speed	6	Soft-Stop (steepness)
	2	Acceleration	7	Minimum pressure (UP) / Offset sol. (DOWN)
	3	Fast speed	8	Demand signal
	4	Deceleration	9	Solenoid control voltage
	5	Slow speed		

For parameter adjustment ⇒ page 69, chapter 5.5.1

### 5.4 Overview of control parameters (PID)

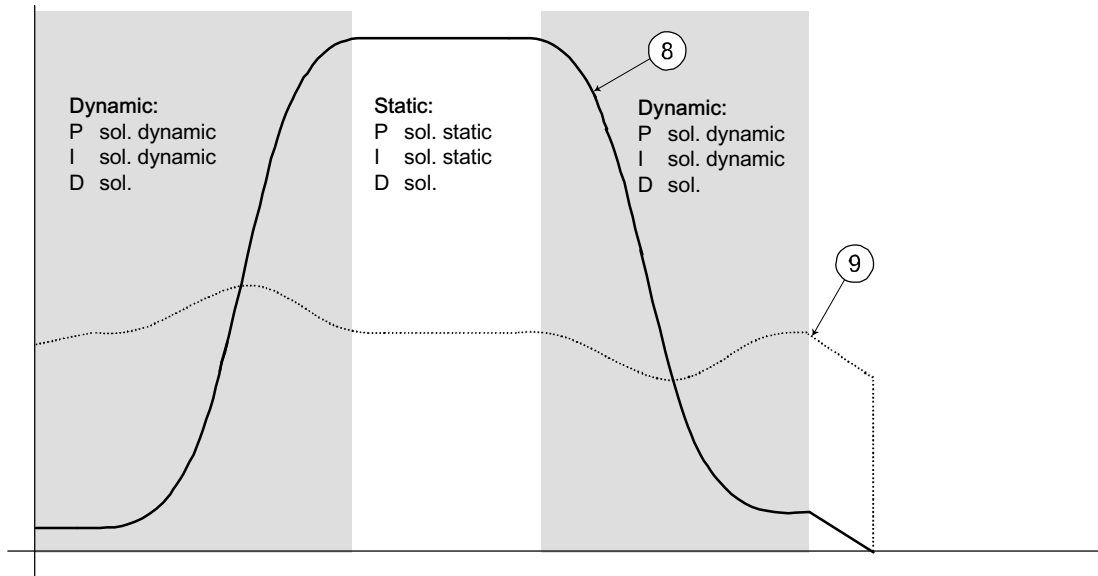

Legend	8	Demand signal	9	Solenoid control voltage
--------	---	---------------	---	--------------------------

## 5.5 Description of parameters

### 5.5.1 Demand values menu

 ↑ UP  
 ↓ DOWN

Parameter name (Miniterminal)	Setting range	Default	Effect	Note
Start speed (P1.01 / P1.11)	0.05 ... 0.5 V	↑ 0.30 V ↓ 0.30 V	Increasing values: <ul style="list-style-type: none"> <li>Higher starting speed</li> <li>Shorter starting time</li> <li>Harsher start-up jerk</li> </ul>	Low settings: Long starting time possible
Min. pressure (P1.02)	2.0 ... 100.0 bar With "Language" set to "English US": 29 ... 1450 psi	↑ 20.0 bar  ↑ 290 psi	Increasing values: <ul style="list-style-type: none"> <li>Higher solenoid starting voltage</li> <li>Shorter starting time</li> </ul>	High settings: Start-up jerk possible
Offset sol. (P1.12)	1.00 ... 7.00 V	↓ 4.00 V	Increasing values: <ul style="list-style-type: none"> <li>Higher solenoid starting voltage</li> <li>Shorter starting time</li> </ul>	High settings: Start jerk possible
Acceleration (P1.04 / P1.14)	0.30 ... 5.00 V/s	↑ 2.00 V/s ↓ 2.00 V/s	Increasing values: Steeper acceleration, i.e. shorter acceleration distance	
Fast speed (P1.05 / P1.17)	1.00 ... 10.00 V	↑ 7.00 V ↓ 7.00 V	Increasing values: Higher travel speed	Conversion example: l / min $\Leftrightarrow$ V, $\Rightarrow$ page 79, chapter 5.6
Deceleration (P1.06 / P1.18)	0.30 ... 5.00 V/s	↑ 3.00 V/s ↓ 3.00 V/s	Increasing values: Steeper deceleration, i.e. shorter deceleration distance	
Slow speed (P1.07 / P1.20) Effective after fast travel	0.20 ... 2.50 V	↑ 0.40 V ↓ 0.40 V	Increasing values: Higher travel speed	<ul style="list-style-type: none"> <li>Low values for "slow speed": unsteady slow travel possible, caused by static friction from cylinder and car guides</li> <li>Low values for "slow speed" and "Soft-Stop": Slight differences in levelling accuracy possible</li> </ul>
Soft-Stop (P1.08 / P1.21)	0.20 ... 5.00 V/s  Switch off: set 5.00 V/s	↑ 1.00 V ↓ 1.00 V	Increasing values: <ul style="list-style-type: none"> <li>Steeper deceleration, i.e., shorter stopping distance</li> <li>Harsher stopping jerk</li> </ul>	Low values for "Slow speed" and "Soft-Stop": Slight variations in levelling accuracy possible
Relevelling up/down (P1.09 / P1.22) Effective during fine adjustment (re- levelling and anti- creeping)	0.20 ... 1.50 V	↑ 0.40 V ↓ 0.40 V	Increasing values: Higher travel speed	<ul style="list-style-type: none"> <li>Low values for "Relevelling up/down": Unsteady slow travel possible, caused by static friction from cylinder and car guides</li> <li>Low values for "Relevelling" and "Soft-Stop": Slight variations in levelling accuracy possible</li> </ul>

Parameter name (Miniterminal)	Setting range	Default	Effect	Note
<b>P sol. static</b> Effective in steady-state control processes (constant-speed travel)	↑ 0.20 ... 1.50 ↓ 0.20 ... 3.00	<i>LRV-1*</i> : ↑ 0.80 ↓ 0.70 <i>LRV 175-1 120 bar (1740 psi)</i> : ↑ 1.40 ↓ 1.20	Increasing values: Higher solenoid control gain	* all types except for LRV 175-1 120 bar (1740 psi) High values: oscillations possible
<b>I sol. static</b> Effective in steady-state control processes (constant-speed travel)	100 ... 1000 ms	<i>LRV 175-1*</i> : ↑ 900 ms ↓ 700 ms <i>LRV 175-1 120 bar (1740 psi)</i> : ↑ 700 ms ↓ 700 ms <i>LRV 350-1, LRV 700-1</i> : ↑ 900 ms ↓ 1000 ms	Increasing values: Longer solenoid integral time	* all types except for LRV 175-1 120 bar (1740 psi) Low values: Oscillations possible
<b>D sol.</b>	0 ... 100 ms  Switch off: set 0 ms	↑ 20 ms ↓ 20 ms	Increasing values: Longer solenoid derivative time	With high values: Oscillations possible
<b>P sol. dynamic</b> Effective in dynamic control processes (acceleration, deceleration)	↑ 0.20 ... 1.50 ↓ 0.20 ... 3.00	<i>LRV-1*</i> : ↑ 0.80 ↓ 0.70 <i>LRV 175-1 120 bar (1740 psi)</i> : ↑ 1.40 ↓ 1.20	Increasing values: Higher solenoid control gain	* all types except for LRV 175-1 120 bar (1740 psi) High values: Oscillations possible
<b>I sol. dynamic</b> Effective in dynamic control processes (acceleration, deceleration)	100 ... 1000 ms	<i>LRV 175-1*</i> : ↑ 450 ms ↓ 350 ms <i>LRV 175-1 120 bar (1740 psi)</i> : ↑ 350 ms ↓ 350 ms <i>LRV 350-1, LRV 700-1</i> : ↑ 450 ms ↓ 500 ms	Increasing values: <ul style="list-style-type: none"> <li>• Longer solenoid integral time</li> <li>• Greater control deviation in dynamic processes</li> </ul>	* all types except for LRV 175-1 120 bar (1740 psi) Low values: Oscillations possible
<b>Calibr. factor</b>	0.90 ... 1.30	↑ 1.00 ↓ 1.00	Valve calibration (actual value)	The DELCON board delivered with the valve is adjusted to the valve.  If the DELCON board is exchanged, transfer the content of the "Calibr. factor" to the new board!

5.5.2 Options menu 

Parameter name (Miniterminal)	Setting range	Default	Effect	Note
Valve type (P2.01)	Handterminal (Miniterminal) LRV 175-1 (1) LRV 350-1 (2) LRV 700-1 (3) LRV 175-A (4) LRV 350-A (5) LRV 175 (6) LRV 350 (7) LRV 700 (8) C-LRV 175 (11) C-LRV 350 (12) C-LRV 700 (13) LRV 175-1 120bar (1740 psi) (14) LRV 350-1 PM (15) LRV 700-1 PM (16)		Valve type selection The current control parameters (PID) will be overwritten with factory settings for the selected valve	

Parameter name (Miniterminal)	Setting range	Default	Effect	Note
SIU type (P2.03)	1 (1) 1 + 4 (3) EN81-20 (5) North America (6)	EN81-20 (5)	<p>SIU-1: monitoring of the demand/feedback speed difference</p> <ul style="list-style-type: none"> <li>Monitoring starts as soon as the command "Fast" is present</li> <li>Monitoring ends when the command "Slow" drops out</li> <li>Monitoring both upper and lower limits</li> <li>Also for auxiliary (reduced) speeds (K6, K7, K8)</li> <li>No monitoring at inspection speed (K5)</li> <li>No monitoring during re-levelling and anti-creeping</li> <li>No monitoring during soft-stop-phase</li> </ul> <p>SIU-4: monitoring of the upper limit of the speed set with "SIU-4 threshold"</p> <ul style="list-style-type: none"> <li>Monitoring of all travel phases, incl. inspection speed (K5), during re-levelling and anti-creeping, soft-stop phase</li> <li>Useful for monitoring the speed in the unlocking zone of the door acc. to EN 81-2, sect. 7.7</li> </ul> <p>The effect of the setting "SIU type" also depends on the setting "Relay function", ⇒ table on page 75</p> <p>As from software version 2.150 the setting "off" is no longer available and is also not required for the execution of the bypass setting procedure (⇒ page 53 ff., chapter 4.3.3) nor for the execution of the max. operating pressure setting procedure (⇒ page 56, chapter 4.3.4) nor the pipe rupture valve test (⇒ page 62, chapter 4.3.11).</p> <p>EN81-20: monitoring ground fault in the solenoid control and SIU-1</p> <ul style="list-style-type: none"> <li>Monitoring in use during down travel</li> <li>Even with additional speed (K6, K7, K8)</li> <li>No monitoring of SIU-1 at inspection speed</li> <li>No monitoring of SIU-1 during re-levelling</li> <li>No monitoring during soft-stop-phase for SIU-1</li> <li>In order for the DELCON card to detect a ground fault, GND and ground must be interconnected (observe the note on page 28)</li> </ul> <p>North America: as in "EN81-20", but additionally</p> <ul style="list-style-type: none"> <li>actual value monitoring regarding plausibility and edge during slow speed</li> <li>check the solenoid actuation circuit</li> <li>during power-up no move command must be present</li> <li>special installation run with K2/K4 and K8</li> <li>check mechanical zero point setting . ⇒ see chapter 4.3.9</li> </ul>	
SIU-1 difference (P2.04)	20 ... 50 % of fast travel speed	25 %	Permissible demand/feed-back difference of fast travel speed	
SIU-4 threshold (P2.05)	0.1 ... 5.0 V	2.5 V	Feedback threshold	Determining the SIU-4 threshold:
Effective only when SIU-4 is activated			$\text{Demand value fast UP} \times \frac{\text{Permissible speed in the unlocking zone of the door acc. to EN 81-2 7.7}}{\text{Car speed fast UP}} = \dots [\text{Volt}]$	

Parameter name (Miniterminal)	Setting range	Default	Effect	Note
Accel. inspection (P2.16) Effective only with inspection travel (K5)	0.30 ... 5.00 V/s	2.00 V/s	Increasing values: Steeper acceleration, i.e. shorter acceleration distance	
Inspection speed (P2.06) Effective only with inspection travel (K5)	20 ... 80 % of fast travel speed	40 %	Increasing values: Higher travel speed	If the lift is designed acc. to ASME A17.1: the inspection speed must not exceed 0.75 m/s.
Decel. inspection (P2.07) Effective only with inspection travel (K5)	0.30 ... 10.00 V/s	7.00 V/s	Increasing values: Steeper deceleration, i.e. shorter deceleration distance	
K6/K7/K8 acceleration (P2.18 / P2.20 / P2.22) Effective only with auxiliary speeds K6, K7, K8	0.30 ... 5.00 V/s	K6: 0.80 V/s K7: 1.20 V/s K8: 1.60 V/s	Increasing values: Steeper acceleration, i.e. shorter acceleration distance	
K6/K7/K8 speed (P2.08 / P2.10 / P2.12)) Effective only with auxiliary speeds K6, K7, K8	20 ... 100 % of fast travel speed	K6: 20 % K7: 30 % K8: 40 %	Fast speed is reduced with K6, K7, K8 Increasing values: Higher travel speed	
K6/K7/K8 deceleration (P2.09 / P2.11 / P2.13) Effective only with auxiliary speeds K6, K7, K8	0.30 ... 5.00 V/s	K6: 1.20 V/s K7: 1.80 V/s K8: 2.40 V/s	Increasing values: Steeper deceleration, i.e. shorter deceleration distance	
Decel. emergency (P2.14) Effective with emergency stop	5.00 ... 10.00 V/s	10.00 V/s		Reasons for emergency stop: <ul style="list-style-type: none"> <li>• SIU-1 error (Err:SIU-1)</li> <li>• Runtime error</li> <li>• Fault</li> <li>• Both travel commands dropped out during fast travel</li> </ul>
Pulsation sol. (P2.15)	120 ... 220 Hz	220 Hz	Increasing values: higher solenoid pulse frequency	
Demand val. red. (P2.24)	Off (1) Few sensitive (2) Normal (3) Sensitive (4)	Normal (3)	Setting the sensitivity of the automatic demand-signal reduction	
Start delay (P2.25)	0.1 ... 1.0 s	0.1 s	Pause between command and start of travel Increasing values: longer pause	

Parameter name (Miniterminal)	Setting range	Default	Effect	Note
Relay function (P2.26)	only SIU1 (1) all errors (2) only SIU4 (3) all errors +FT (4)	only SIU1 (1)	The relay on the power supply unit switches (⇒ see chapter 1.8.1) either only for SIU-1 error, SIU-4 error, all errors or all errors plus function test	The effect of the setting "Relay function" also depends on the setting "SIU type", ⇒ table on page 75
Command input (P2.27)	Bucher K1..K8 (1) ELRV K1..K8 (2) binary B1..B4 (3) 3 Sign. K1..K8 (4) US mode K1..K8 (5)	Bucher K1..K8 (1)	Selection of command evaluation; ⇒ table Command evaluation page 76	On the control side it must be guaranteed that a command change is concluded within 20 ms.
Auxiliary curve (P2.28)	0 ... 20	0	Assistance with fault-finding	Only for PC operation and after consultation with Bucher Hydraulics Service Department!
Edge detection (P2.29)	sensitive (1) normal (2) insensitive (3)	normal (2)	Edges on the actual value signal lead to travel stop	Only effective if SIU type "North America" is selected

**Results of the combined settings of “SIU type” and “Relay function”**

Setting SIU Type	Setting relay function	Event	Indication ERROR LED	Indication SIU-1 LED	Relay actuates	Emergency stop	Reset
1	only SIU-1	SIU-1	X	X	X	X	immediately, when there is no longer a travel command
1	only SIU-1	SIU-4					
1 + 4	only SIU-1	SIU-1	X	X	X	X	immediately, when there is no longer a travel command
1 + 4	only SIU-1	SIU-4					
1	all errors	SIU-1	X	X	X	X	after 2 sec, travel starts again
1	all errors	SIU-4					
1 + 4	all errors	SIU-1	X	X	X	X	after 2 sec, travel starts again
1 + 4	all errors	SIU-4			X		immediately, when the speed is less than the threshold
1	only SIU-4	SIU-1	X	X		X	immediately, when there is no longer a travel command
1	only SIU-4	SIU-4					
1 + 4	only SIU-4	SIU-1	X	X		X	immediately, when there is no longer a travel command
1 + 4	only SIU-4	SIU-4			X		immediately, when the speed is less than the threshold

The relay function setting “all errors +FT” acts like the setting “all errors”, however additionally the relay in standstill can be switched through K7. This way the function monitoring of the DELCON can be realized.

## Command evaluation

Command input	Buchser K1..K8								ELRV K1..K8								binary B1..B4				3 Sign. K1..K8						US mode									
	1	2	3	4	5	2	2	2	1	2	3	4	5	2	2	2	1	2	3	4	1/3 B)	4	5	2	2	2	1	2	3	4	5	6	7	8		
Terminal	K1	K2	K3	K4	K5	K6	K7	K8	K1	K2	K3	K4	K5	K6	K7	K8	B1	B2	B3	B4	K1 / K3	K2	K4	K5	K6	K7	K8	K1	K2	K3	K4	K5	K6	K7	K8	
up	Standstill	0	0	0	0	-	-	-	-	0	0	0	0	-	-	-	-	1	0	0	0	-	0	0	-	-	-	-	0	0	0	0	-	-	-	-
	Relevelling	0	1	0	0	-	-	-	-	0	1	0	0	1	-	-	-	1	1	0	0	0	1	0	-	-	-	0	1	0	0	-	-	-	-	
	Slow speed	0	1	0	0	-	-	-	-	0	1	0	0	0	-	-	-	1	0	1	0	0	1	0	-	-	-	0	1	0	0	-	-	-	-	
	Insp. speed	1	-	0	0	1	-	-	-	1	-	0	0	1	-	-	-	1	1	1	0	1	1	0	1	-	-	-	1	1	0	0	1	-	-	-
	V K6	1	-	0	0	0	1	-	-	1	-	0	0	0	1	-	-	1	0	0	1	1	1	0	0	1	-	-	1	0	0	0	0	1	-	-
	V K7	1	-	0	0	0	0	1	-	1	-	0	0	0	0	1	-	1	1	0	1	1	1	0	0	0	1	-	1	0	0	0	0	0	1	-
	V K8	1	-	0	0	0	0	0	1	1	-	0	0	0	0	0	1	1	0	1	1	1	1	0	0	0	0	1	1	0	0	0	0	0	0	1
	Fast speed	1	-	0	0	0	0	0	0	1	-	0	0	0	0	0	0	1	1	1	1	1	1	0	0	0	0	0	1	1	0	0	0	0	0	0
down	Standstill	0	0	0	0	-	-	-	-	0	0	0	0	-	-	-	-	0	0	0	0	-	0	0	-	-	-	-	0	0	0	0	-	-	-	-
	Relevelling	0	0	0	1	-	-	-	-	0	0	0	1	1	-	-	-	0	1	0	0	0	0	1	-	-	-	0	0	0	1	-	-	-	-	
	Slow speed	0	0	0	1	-	-	-	-	0	0	0	1	0	-	-	-	0	0	1	0	0	0	1	0	-	-	0	0	0	1	-	-	-	-	
	Insp. speed	0	0	1	-	1	-	-	-	0	0	1	-	1	-	-	-	0	1	1	0	1	0	1	1	-	-	-	0	0	1	1	1	-	-	-
	V K6	0	0	1	-	0	1	-	-	0	0	1	-	0	1	-	-	0	0	0	1	1	0	1	0	1	-	-	0	0	1	0	0	1	-	
	V K7	0	0	1	-	0	0	1	-	0	0	1	-	0	0	1	-	0	1	0	1	1	0	1	0	0	1	-	0	0	1	0	0	0	1	
	V K8	0	0	1	-	0	0	0	1	0	0	1	-	0	0	0	1	0	0	1	1	1	0	1	0	0	0	1	0	0	1	0	0	0	0	1
	Fast speed	0	0	1	-	0	0	0	0	0	0	1	-	0	0	0	0	0	1	1	1	1	1	0	1	0	0	0	0	0	0	1	1	0	0	0

- a) After a standstill, relevelling is implemented; after fast speed, slow speed.
- b) Command can be applied to terminal 1 or to terminal 3 or to both terminals simultaneously
- c) For movement downwards K3 and K5 or K4 and K5 are necessary
- d) For movement upwards K1 and K5 or K2 and K5 are necessary

Legend	0	Inactive
	1	Active
	-	Any

### 5.5.3 Zero point / Hall sensor menu **3**

Parameter name (Miniterminal)	Setting range	Default	Effect	Note
Zero point	Displays the current feedback value	0.000 V	<b>Beep tone</b> (continuous) if feedback value outside the permissible range <b>Beep tone</b> (intermittent) The shorter the sound, the closer the feedback value is to zero.	Instructions for "Setting the mechanical zero point" ⇒ page 60, chapter 4.3.9

### 5.5.4 Information menu **4**

Parameter name (Miniterminal)	Setting range	Default	Effect	Note
Language/ Sprache	English Deutsch (=German) Francais (=French) Italiano (=Italian) Espanol (=Spanish) English US	Deutsch (=German)	User language is set	"English US" causes the "Min. pressure" (P1.02) to be displayed in psi
Load parameter	load factory (=factory settings) load user (=user settings)		Overwrites the current parameters with the internally-saved parameters	
Save parameter			Saves the current DELCON parameters as the User parameter set	
Password	4 numerals protection not activated: 0000	0000 (ex. factory)	Protection against parameter changes	
Delete errors			Clear error memory	
Pipe rupture (↵)		approx. 30 % higher than normal fast travel speed	Simplified test procedure for the pipe-rupture valve	Final display: max. feedback value Instructions for "Pipe rupture valve test" ⇒ page 62, chapter 4.3.11
1) ... 8) Error (F4.01 ... F4.08)			Error memory for the last 8 errors, with operating-hours count	For possible error messages, warnings, information ⇒ page 84, chapter 5.7.2
Software version (d4.01)			Version of installed software	Example: 2.200
Hardware version (d4.02)			DELCON version	Example: 2.050
Serial number			Serial number of the DELCON	Format: Year/month - sequential number

Parameter name (Miniterminal)	Setting range	Default	Effect	Note
Check number			Valve check number	DELCONs that come ex-works WITH presets for a specific lift control valve have the same check number as the lift control valve.  Format: Year/month - sequential number  DELCONs that come ex-works as spare parts WITHOUT presets for a specific lift control valve have the check number "9999-09999".
Power on	Max. 1.3 million		Number of DELCON switch-ons, including reset-key presses	
Drive up	Max. 1.3 million		Number of UP travels	Relevelling UP (anti creeping) operations are not counted.
Drive down	Max. 1.3 million		Number of DOWN travels	Relevelling DOWN operations are not counted.
Operating hour	max. 131070 h		DELCON operating-hours counter	
+ unstab voltage	+17 ... +41 V		Positive unstabilised voltage from the power supply unit	
- unstab voltage	-17 ... -41 V		Negative unstabilised voltage from the power supply unit	

## 5.6 Calculating the demand values for maximum speed

The label on the rear of the DELCON front plate gives the demand value information.

The demand values for the maximum UP and DOWN speeds can be calculated from the following table:

Valve type	Flow range, Q [l/min.]	Flow ring	Conversion
LRV 175-1	15 ... 45	R 45	1 V $\Leftrightarrow$ 4.8 l/min.
	46 ... 90	R 90	1 V $\Leftrightarrow$ 9.7 l/min.
	91 ... 175	R 175	1 V $\Leftrightarrow$ 19.3 l/min.
	176 ... 250	R 250	1 V $\Leftrightarrow$ 29.1 l/min.
LRV 350-1	150 ... 250	R 250	1 V $\Leftrightarrow$ 26.7 l/min.
	251 ... 350	R 350	1 V $\Leftrightarrow$ 38.3 l/min.
	351 ... 500	R 500	1 V $\Leftrightarrow$ 52.2 l/min.
LRV 700-1	400 ... 700	R 700	1 V $\Leftrightarrow$ 78.0 l/min.
	701 ... 1000	R 1000	1 V $\Leftrightarrow$ 112.0 l/min.

SWISS MADE

**BUCHER**  
 hydraulics

① LRV175-1    ② R175/K251/VN  
 ③ 120 / 150 l/min    ④ 21 / 45 bar  
 P min-max/adj 7-63 / 55 bar

### Calculation example:

③ Flow rate UP (Q) 120 l/min.  
 ④ Flow rate DOWN (Q) 150 l/min.

### Valve selection:

① Valve type LRV 175-1  
 Flow range 91 ... 175 l/min. \*  
 ② Flow ring R 175  
 Conversion 1 V  $\Leftrightarrow$  19.3 l/min. \*

### Conversion:

Flow rate UP:  
 $120 \text{ [l/min]} / 19.3 \text{ [l/min]} = 6.22 \text{ V Fast UP}$

Flow rate DOWN:  
 $150 \text{ [l/min]} / 19.3 \text{ [l/min]} = 7.77 \text{ V Fast DOWN}$

→ Settings in the DELCON

\* These values are taken from the above table.

## 5.7 Faults / Fault-finding

### 5.7.1 Check list for fault correction

Fault	Cause	Corrective action	Page (chapter)
No UP travel	• Motor / pump not running	• Check connection	49 (4.2.3)
	• Wiring fault	• Check wiring	
	• Control cabinet	• Check power supply	49 (4.2.3)
	• Motor running on 2 phases		
	• Motor- and/or oil-PTC thermistor has operated		
	• Electronic soft-starter not connected properly	• Connect in accordance with diagram	49 (4.2.3)
	• UP solenoid not energised	• Check the safety relays R2	
	• Command K1/K2 not present and/or R2 not closed	• Check connections after power supply unit	60 (4.3.9)
• SIU-1 (demand/feedback monitoring) has activated, LED "SIU-1" on DELCON lights up	• Check control of power supply unit		
No UP travel	• DOWN solenoid is energised	• Check mechanical zero point	49 (4.2.3)
	• UP pilot filter dirty	• Correct the wiring fault	61 (4.3.10)
		• NTA-2, terminals 7+8 crossed?	
		• Clean filter. If necessary, filter oil	
Car does not reach speed	• Pressure-relief valve set too low	• Check pressures/ consult factory	56 (4.3.4)
Cannot lift maximum load	• Pressure-relief valve set too low	• Check pressures/ consult factory	56 (4.3.4)
	• Overload switch DZ has activated	• Reduce the load	
	• Leakage between pump and valve	• Eliminate the leakage	
UP-travel starting problems	• Jerk when starting	• Readjust bypass-pressure setscrew ② on the valve	53 (4.3.3)
	• Travels UP without any command	• Bypass-pressure setscrew ② on the valve is set too high. Readjust it.	53 (4.3.3)

Fault	Cause	Corrective action	Page (chapter)
Car does not reach landing	<ul style="list-style-type: none"> <li>Oil level in power unit is below minimum</li> </ul>	<ul style="list-style-type: none"> <li>Top-up when car is at lowest landing</li> </ul>	52 (4.3.2)
	<ul style="list-style-type: none"> <li>Leakage: valve - cylinder</li> <li>Mechanical zero point is displaced</li> <li>Plunger cylinder is at end-stop</li> <li>Extension of telescopic cylinder is not synchronised</li> <li>Ratio of top- to bottom-overtravel is wrong</li> </ul>	<ul style="list-style-type: none"> <li>Check for leakage</li> <li>Check</li> <li>Cylinder pillar is too short</li> <li>Check cylinder stroke</li> <li>Check synchronisation of stages</li> <li>Telescopic cylinder is sitting too low; raise it</li> <li>2-stage: <math>\frac{1}{2}</math> bottom / <math>\frac{1}{2}</math> top</li> <li>3-stage: <math>\frac{1}{3}</math> bottom / <math>\frac{2}{3}</math> top</li> </ul>	60 (4.3.9)  ⇒ document 300-P-9010023
Car overshoots landing during UP travel	<ul style="list-style-type: none"> <li>Shaft switch wrongly positioned</li> </ul>	<ul style="list-style-type: none"> <li>Position correctly</li> </ul>	58 (4.3.8)
	<ul style="list-style-type: none"> <li>Mechanical zero point is displaced</li> </ul>	<ul style="list-style-type: none"> <li>Check</li> </ul>	60 (4.3.9)
	<ul style="list-style-type: none"> <li>Deceleration is too low</li> <li>Bypass pressure set too high</li> </ul>	<ul style="list-style-type: none"> <li>Increase deceleration in DELCON</li> <li>Readjust it</li> </ul>	53 (4.3.3)
No DOWN travel	<ul style="list-style-type: none"> <li>Car overloaded, pressure switch has activated</li> <li>Command K3/K4 not present and/or R1 not closed</li> <li>No current from power supply unit</li> <li>UP solenoid is energised</li> <li>DOWN solenoid not energised</li> </ul>	<ul style="list-style-type: none"> <li>Reduce the load</li> <li>Check the safety relays R1</li> <li>Test the voltage; exchange unit</li> <li>Correct the wiring fault</li> <li>Exchange solenoid plug on valve</li> <li>Check voltage at terminal 7</li> <li>Check connection from terminal 7 to DOWN solenoid (safety relay R1)</li> </ul>	49 (4.2.3)

Fault	Cause	Corrective action	Page (chapter)
Lift starts DOWN, then stops	<ul style="list-style-type: none"> <li>• SIU-1 (demand/feedback monitoring) activates, LED "SIU-1" on DELCON lights up</li> <li>• Acceleration is too high</li> <li>• Fast DOWN set too high in DELCON</li> <li>• Closing flow rate of the pipe rupture valve set too low, pipe rupture valve has activated</li> </ul>	<ul style="list-style-type: none"> <li>• DELCON settings are too low</li> <li>• Decrease the acceleration setting</li> <li>• Reduce Fast DOWN</li> <li>• Use properly adjusted pipe rupture valve</li> </ul>	79 (5.6)
DOWN speed is too slow	<ul style="list-style-type: none"> <li>• Car is too light</li> <li>• Diameter of hydraulic line to the cylinder is too small / dynamic pressure is too low</li> <li>• Oil is too cold</li> <li>• Too much friction in system</li> </ul>	<ul style="list-style-type: none"> <li>• Add weight to the car</li> <li>• Line with larger diameter</li> <li>• Install oil heater</li> <li>• Provide parking circuitry</li> <li>• Align cylinder and rails</li> </ul>	
Car stops before reaching landing during DOWN travel	<ul style="list-style-type: none"> <li>• Shaft switch wrongly positioned</li> </ul>	<ul style="list-style-type: none"> <li>• Set as per page(s)</li> </ul>	58 (4.3.8)
	<ul style="list-style-type: none"> <li>• Safety relay R1 drops out too early, or without a delay</li> </ul>	<ul style="list-style-type: none"> <li>• Set as per page(s)</li> </ul>	24 (1.7.4)
Car overshoots landing during DOWN travel	<ul style="list-style-type: none"> <li>• Deceleration is too low</li> </ul>	<ul style="list-style-type: none"> <li>• Increase deceleration in DELCON</li> </ul>	
	<ul style="list-style-type: none"> <li>• Deceleration switches in shaft wrongly positioned</li> </ul>	<ul style="list-style-type: none"> <li>• Set as per page(s)</li> </ul>	58 (4.3.8)
	<ul style="list-style-type: none"> <li>• Feedback sensor (Hall sensor) GND not connected</li> </ul>	<ul style="list-style-type: none"> <li>• Connect GND to terminal 12</li> </ul>	49 (4.2.3)
	<ul style="list-style-type: none"> <li>• Demand values set too high</li> </ul>	<ul style="list-style-type: none"> <li>• Set as per page(s)</li> </ul>	79 (5.6)
	<ul style="list-style-type: none"> <li>• DOWN pilot filter contaminated</li> </ul>	<ul style="list-style-type: none"> <li>• Clean pilot filter</li> </ul>	61 (4.3.10)
	<ul style="list-style-type: none"> <li>• Oil is too cold</li> </ul>	<ul style="list-style-type: none"> <li>• Consider installing oil heater; provide parking circuitry</li> </ul>	

Fault	Cause	Corrective action	Page (chapter)
Leakage in hydraulic system (test only when oil is cold): Pressure drop in approx. 3 minutes is not more than 5 bar (with ball valve closed)	<ul style="list-style-type: none"> <li>Pressure drop is in the permissible range</li> </ul>	<ul style="list-style-type: none"> <li>None</li> </ul>	
Leakage in hydraulic system (test only when oil is cold): Pressure drop in approx. 3 minutes is more than 5 bar (with ball valve closed)	<ul style="list-style-type: none"> <li>DOWN pilot pin is bent</li> </ul>	<ul style="list-style-type: none"> <li>Replace DOWN pilot valve</li> </ul>	92 (6.3)
	<ul style="list-style-type: none"> <li>Emergency-lowering valve leaking</li> </ul>	<ul style="list-style-type: none"> <li>While UP-command is present, operate emergency-lowering valve several times</li> </ul>	35 (3.1)
	<ul style="list-style-type: none"> <li>Check valve is leaking</li> </ul>	<ul style="list-style-type: none"> <li>Replace check valve</li> </ul>	11 (1.6)
	<ul style="list-style-type: none"> <li>DOWN spool leaking</li> </ul>	<ul style="list-style-type: none"> <li>Clean seat and reassemble. Check that spool seals properly, otherwise replace.</li> </ul>	
Car sinks (with ball valve closed)	<ul style="list-style-type: none"> <li>Oil is just cooling down!</li> <li>Leak in cylinder or connecting line</li> </ul>	<ul style="list-style-type: none"> <li>None</li> <li>Check/tighten connecting hose. Renew seals, if necessary</li> </ul>	

### 5.7.2 Error messages

Display Handterminal (Miniterminal) <i>Effect</i>	Cause	Analysis / Remedy	Monitoring	Message saved	Message reset
Err:None (0) <i>No error</i>	—	—	—	—	—
Err: Current (1) <i>Travel disabled; relay actuates depending on parameter "Re- lay function"</i>	Solenoid current greater than 1.5 A  Solenoid coil is faulty  Delcon is faulty	Replace the solenoid  Replace the Delcon	During travel	At end of travel	Manual reset required
Err:Input-V+ (3) <i>Travel disabled; relay actuates depending on parameter "Re- lay function"</i>	Positive voltage from power supply unit is outside of +17V ... +41V  Positive voltage is too low or too high  Unsuitable voltage range of the power supply unit  Power supply unit de- fective	Check the incoming mains voltage  Choose the correct power supply unit to suit the mains voltage  Replace the power supply unit  Contact the customer ser- vice  Replace the power supply unit	At start of travel During travel	If at stand- still, immedi- ately; if trav- elling, at end of travel	When the cause has been re- moved
Err:Input-V- (22) <i>Travel disabled; relay actuates depending on parameter "Re- lay function"</i>	Negative voltage from power supply unit is outside of -17V ... -41V  Negative voltage is too low or too high  Unsuitable voltage range of the power supply unit  Power supply unit de- fective	Check the incoming mains voltage  Choose the correct power supply unit to suit the mains voltage  Replace the power supply unit  Contact the customer ser- vice  Replace the power supply unit	At start of travel During travel	If at stand- still, immedi- ately; if trav- elling, at end of travel	When the cause has been re- moved

Display Handterminal (Miniterminal) <i>Effect</i>	Cause	Analysis / Remedy	Monitoring	Message saved	Message reset
<b>Err:SIU-1 (5)</b> <i>Travel is aborted; relay actuates depending on parameter "Relay function"; LED SIU-1 lights up)</i>	<b>Demand/feedback difference too large</b> SIU-1 difference on DELCON too low Acceleration is too high Fast DOWN is set too high on the DELCON Closing flow rate of the pipe rupture valve set too low, pipe rupture valve has activated	Increase value SIU-1 difference on DELCON Decrease the acceleration setting Reduce fast DOWN Increase the closing flow rate of the pipe rupture valve (by authorized personnel only!)	During travel Not monitored if travel is executed with additional command K5 (inspection travel)	At end of travel	If the "Relay function" setting is "only SIU1": reset operation after there is no longer any travel command. If the "Relay function" setting is "all errors": delay of 2 s.
<b>Err:Command (7)</b> <i>Travel disabled; relay actuates depending on parameter "Relay function"</i>	<b>Incorrect combination of commands</b> e.g. UP and DOWN simultaneously	Ensure correct commands are signalled	At start of travel During travel Not monitored if travel is executed with additional command K5 (inspection travel)	If at standstill, immediately; if travelling, at end of travel	When the cause has been removed
<b>Err:0-Point + (15)</b> <i>Travel disabled; relay actuates depending on parameter "Relay function"</i>	<b>Automatic zero point equalisation above +1.00 V</b> <b>At inspection travel: Automatic zero point equalisation above approx. +5.00 V</b> Bypass pressure is too high	Set the bypass screw on the valve correctly (unscrew it slightly)	At start of travel	Immediately	Delay of 2 s
<b>Err:0-Point – (16)</b> <i>Travel disabled; relay actuates depending on parameter "Relay function"</i>	<b>Automatic zero point equalisation below –1.00 V</b> <b>At inspection travel: Automatic zero point equalisation below approx. –5.00 V</b> Emergency lowering valve actuated Leakage	For releveling tests, only actuate the emergency lowering briefly Rectify leakage	At start of travel	Immediately	Delay of 2 s
<b>Err:Wrong SW (9)</b> <i>Travel disabled; relay actuates depending on parameter "Relay function"</i>	<b>Software fault</b> Wrong EPROM installed Software initialisation fault	Change the EPROM Replace the DELCON	During powering up	Immediately	When the cause has been removed
<b>Err:Unknown (18)</b>	<b>Unknown fault</b> Internal software fault	Upgrade/reinstall software	At standstill	Display only	—

Display Handterminal (Miniterminal) <i>Effect</i>	Cause	Analysis / Remedy	Monitoring	Message saved	Message reset
<b>Err:U+15V (31)</b>  <i>Travel disabled; relay actuates depending on parameter "Re- lay function"</i>	Internal +15 V voltage faulty		At start of travel During travel	If at stand- still, immedi- ately; if trav- elling, at end of travel	When the cause has been re- moved
	DELCON defective	Replace DELCON			
<b>Err:U-15V (32)</b>  <i>Travel disabled; relay actuates depending on parameter "Re- lay function"</i>	Internal -15 V voltage faulty		At start of travel During travel	If at stand- still, immedi- ately; if trav- elling, at end of travel	When the cause has been re- moved
	DELCON defective	Replace DELCON			
<b>Err: SMA9 (33)</b>  <i>Travel disabled; relay actuates depending on parameter "Re- lay function"</i>	ground fault	check wiring	during down travel	at end of travel	Delay of 6s
	solenoid current is too small	replace the solenoid			
	solenoid coil is faulty	replace Delcon			
	Delcon is faulty				
<b>Err: Cmd T0 (34)</b>  <i>Travel disabled; relay actuates depending on parameter "Re- lay function"</i>	Command present during power-up	check wiring Actuate the command correctly	During powering up	Immediately	When the cause has been re- moved
<b>Err: FB tol. (35)</b>  <i>If at standstill: travel disabled; during travel: travel is aborted; relay actuales de- pending on pa- rameter "Relay function"</i>	Actual value signal outside valid value range	check wiring Reset the mechanical zero point	At start of travel During travel	at end of travel	After no more travel command is present

Display Handterminal (Miniterminal) Effect	Cause	Analysis / Remedy	Monitoring	Message saved	Message reset
<b>Err: FB edge (36)</b> <i>Travel disabled; relay actuates depending on parameter "Re- lay function"</i>	Change of actual value signal exceeds tolerance limit	check wiring	At start of travel During travel	at end of travel	After no more travel command is present
<b>Err: SMA (37)</b> <i>If at standstill: travel disabled; during travel: travel is aborted; relay actuates de- pending on pa- rameter "Relay function"</i>	Error in the actuation circuit of the solenoid coil	check wiring replace Delcon	At start of travel During travel	at end of travel	After no more travel command is present

### 5.7.3 Warnings

Display Handterminal (Miniterminal) Effect	Cause	Analysis / Remedy	Monitoring	Message saved	Message reset
<b>Warn:Board-T. (2)</b>	<b>Temperature of DELCON exceeds 70 °C (158 °F)</b>  Ambient temperature is too high  Control cabinet ventilation missing Poor ventilation in control cabinet	Lower the ambient temperature  Improve control cabinet ventilation	At standstill	Immediately	When the cause has been removed
<b>Warn:0 Point (14)</b>	<b>Zero point outside of ±0.20 V</b>  Mechanical zero point is wrongly set  Bypass pressure is too high	Reset the mechanical zero point  Set the bypass screw on the valve correctly (unscrew it slightly)	At start of travel	Immediately	Immediately (save only)

Display Handterminal (Miniterminal) <i>Effect</i>	Cause	Analysis / Remedy	Monitoring	Message saved	Message reset
Warn:A0-Point (17)	Zero point outside of 1.00 V during releveling	Reset the mechanical zero point	At start of travel Not monitored if additional command K5 (inspection travel) is present	Immediately	Immediately (save only)
	Mechanical zero point is wrongly set				
	Bypass pressure is too high	Set the bypass screw on the valve correctly (unscrew it slightly)			
Warn:Demand (19)	Emergency lowering valve actuated	For releveling tests, only actuate the emergency lowering briefly	At start of travel Not monitored if additional command K5 (inspection travel) is present	Immediately	Immediately (save only)
	Automatic demand signal reduction was invoked, maximum speed was reduced for this travel	Decrease the fast speed	During travel, depending on parameter "Demand val. red."	At end of travel	Immediately (save only)
	Fast speed too high				
	Oil temperature too low				
Too heavy a load with hot oil	Install an oil cooler, do not overload the car				
Warn:Bypass pre (25)	Automatic zero point equalisation above +0.20 V	Set the bypass screw on the valve correctly (unscrew it slightly)	At start of travel Not monitored if additional command K5 (inspection travel) is present	Immediately	Immediately (save only)
	Hand pump activated				
Warn:Leakage (26)	Bypass pressure is too high				
	Automatic zero point equalisation below -0.20 V	For releveling tests, only actuate the emergency lowering briefly	At start of travel Not monitored if additional command K5 (inspection travel) is present	Immediately	Immediately (save only)
	Emergency lowering valve actuated				
Leakage	Rectify leakage				
Warn:Relevel (27) <i>Travel is aborted (relay does not actuate)</i>	Releveling up/down took longer than 2 minutes	For releveling tests, only actuate the emergency lowering briefly	During travel Not monitored if travel is executed with additional command K5 (inspection travel)	At end of travel	Immediately (save only)
	Emergency lowering valve actuated				

### 5.7.4 Informations

Display Handterminal (Miniterminal)	Cause	Analysis / Remedy	Monitoring	Message saved	Message reset
Info:New vers (12)	New software version installed  New EPROM has been installed		During powering up	Immediately	Immediately (save only)
Info:Default (13)	Factory settings loaded		At standstill	Immediately	Immediately (save only)
Info:Cmd-Dir. (23)	Command direction changed during travel  Fault on K1 ... K4 (terminals 1 to 4)	Cure the cause of the fault	At start of travel During travel Not monitored if travel is executed with additional command K5 (in- spection travel)	If at stand- still, immedi- ately; if trav- elling, at end of travel	Immediately (save only)

## 6 Maintenance

### 6.1 Maintenance schedule

This service plan is just a guide. Adjustments or changes should be undertaken by the installer.

	Work to be carried out	Time						
		Before commissioning	During commissioning	First service after commissioning, not later than after 3 months	At every service, at least 2x per year	Annually	After 5 years	After 10 years
Valve	Check internal leakage		X	X	X			
	Check external leakage		X	X	X			
	Check the maximum pressure setting (pressure relief valve / maximum-pressure setscrew)		X			X		
	Check mechanical zero point (Hall sensor)		X	X	X			
	Clean in the proper manner or replace pilot filters		X	X	X			
	Clean main filter						X — X	
Valve	Renew O-rings (when valve is dismantled, or as required)						X — X	
Pipe Hose	Check for leakage	X	X	X	X			
	Check for <ul style="list-style-type: none"> <li>• Damage to the outer surface (chafing, cracks, cuts)</li> <li>• Embrittlement of the outer surface</li> <li>• Discolouration of the outer surface</li> <li>• Bubbles</li> <li>• Pinches</li> <li>• Kinks</li> <li>• Damaged / deformed fittings</li> </ul>		X			X	X	
	Replace							

## 6.2 Hydraulic fluids and oil additives

Hydraulic characteristics	Description, value, unit
Oil temperature	HL and HM mineral oils to ISO 11158, other fluids – contact BUCHER!

Oil additive: **Shell Tonna S**.

When the movement of the lift cylinder at low speeds tends to be jerky, an oil additive with special sliding properties is required. In this case, the oil additive **Shell Tonna S** is approved.

Alternatively: standard HLP hydraulic oil **Motorex Hydrogliss 202**.

When **Shell Tonna S** cannot be employed, an alternative is to use a standard HLP hydraulic oil together with the oil additive supplied by Bucher Hydraulics AG.

Other oil additives are not permitted.

### ATTENTION!

The volume of oil additive that is mixed in must not exceed 2 % of the existing total oil volume.

Bucher Hydraulics cannot guarantee the proper functioning of the lift control valve if other additives are used or if the maximum permissible amount of the above additives is exceeded.

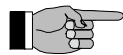

**IMPORTANT!:** Further information and hydraulic oil recommendations can be seen in document 300-D-9010073!

### 6.3 Installation guide for DOWN pilot valve

#### Exchanging the DOWN pilot valve

- Switch main switch OFF
- Close the ball valve
- Vent all pressure in the valve block (manual emergency lowering valve)
- Remove solenoid and the A and C parts
- Assemble the A parts and insert them in the bore
- Insert O-ring (B)
- Assemble the C parts, then insert the unit in the bore. Make sure that the stem of the cone (3) is clearly engaged in the spring.
- Insert O-ring (D) and fit the solenoid  
! If needle (1) slips out of the bush (2), start again from step 7
- Open the ball valve
- Switch main switch ON

The new DOWN pilot valve is ready for use

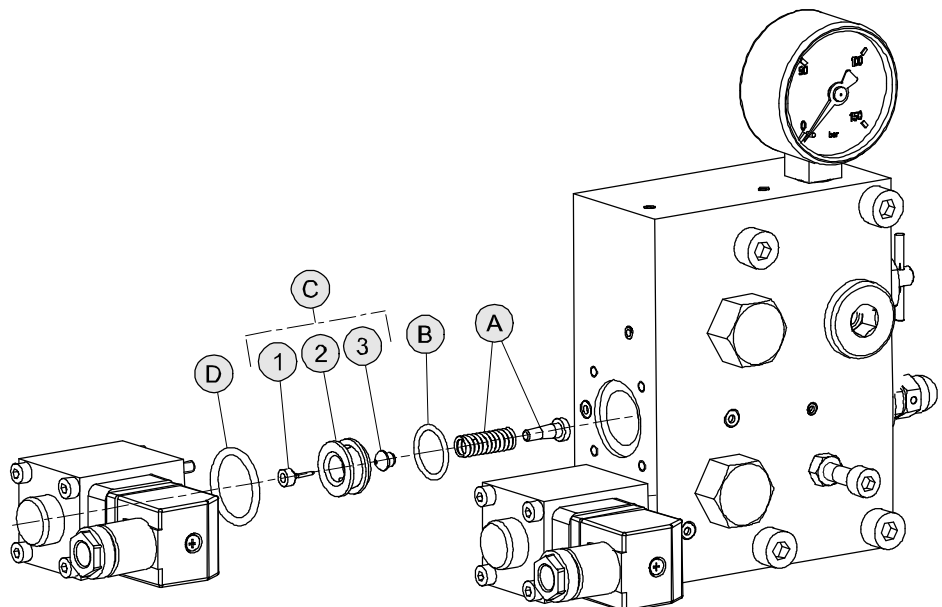

### 6.4 Spare parts

Detailed information on each spare part can be found under the following link:

[www.bucherhydraulics.com/Elevator/Spare-Parts](http://www.bucherhydraulics.com/Elevator/Spare-Parts)