

Service manual



Warner Electric

Industrial Clutches, Brakes, Controls, Tension Systems, Sensors, and Switches

SM431gb - rev 11/22

Electrically Released Brake

ERS VAR07 SZ 600/550

ERS VAR07 SZ 420/350

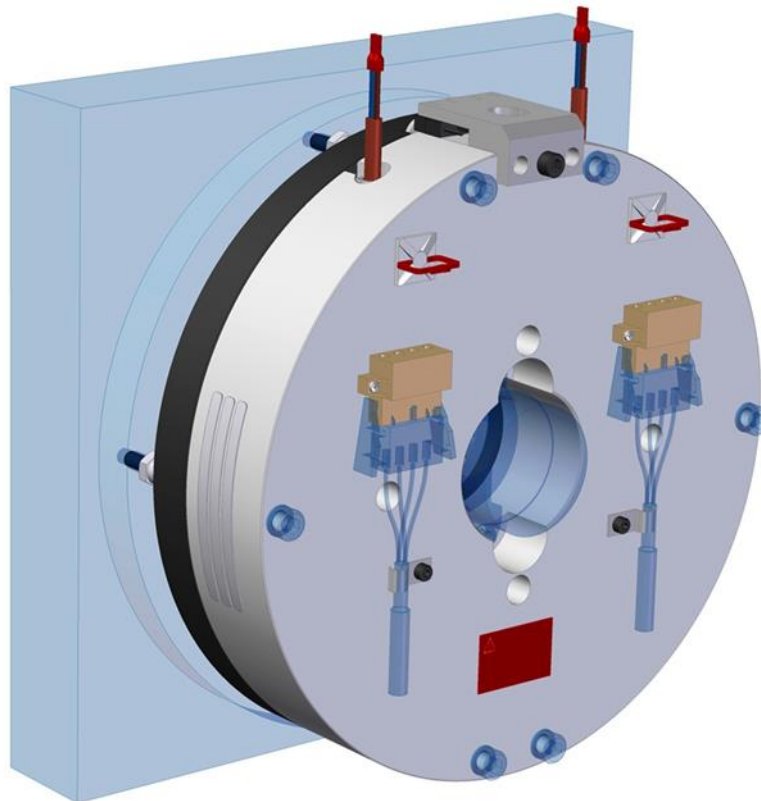

CONTENTS



1-	EU DECLARATION OF CONFORMITY	3
2-	PRECAUTIONS AND SAFETY MEASURES	3
2.1 -	SYMBOLS USED IN THIS MANUAL	3
2.2 -	SAFETY PRECAUTIONS FOR INSTALLATION AND MAINTENANCE	4
2.3 -	PRECAUTIONS FOR HANDLING	5
2.4 -	PRECAUTIONS ON USE	5
2.5 -	RESTRICTIONS ON USE	6
3-	STORAGE	6
4-	TECHNICAL SPECIFICATION	7
4.1 -	BRAKE DESCRIPTION	7
4.2 -	TECHNICAL DATA	7
4.3 -	LABELING DETAILS	8
5-	INSTALLATION	9
5.1 -	CUSTOMER INTERFACE SPECIFICATION	9
5.2 -	BRAKE MOUNTING	9
6-	ELECTRICAL CONNECTION	10
6.1 -	CONNECTOR CONNECTION	11
6.2 -	MICROSWITCH TECHNICAL DATA	11
7-	MAINTENANCE	12
7.1 -	AIR GAP CHECKING	12
7.2 -	DISCS EXCHANGE	12
7.3 -	DETECTION CHECKING	14
7.4 -	DETECTION SETTING	15
7.5 -	MICROSWITCH EXCHANGE	16
8-	SPARE PARTS	17
9-	TOOLING	18
10-	TROUBLESHOOTING	18
11-	CONTACT	18

1- EU Declaration of conformity

The Product described in this manual is in conformity with the relevant EU harmonized legislation:

Directive 2014/33/EU Ensuring lift safety

Directive 2014/35/EU Electrical safety: Low-voltage electrical equipment

Directive 2006/42/EC Machinery safety

Evidence of conformity to the Directives is assured through the application of the following standards:

EN 81-20:2020 Safety rules for the construction and installation of lifts – Lifts for the transport of persons and goods – Parts 20: Passenger and goods passenger lifts.

EN 81-50:2020 Safety rules for the construction and installation of lifts – Examinations and tests – Parts 50: Design rules, calculations, examination and tests of lift components.

Lift Regulation 2016 Guidance on the regulations they apply to lifts and components being supplied in or into Great Britain.

DIN VDE 0580:2011 Electromagnetic devices and components, General requirements.

EN ISO 12100:2010 Safety of machinery – General principles for design – Risk assessment and risk reduction.

2- Precautions and Safety Measures

Precautions and safety measures must be read before any installation or maintenance of the brake. Compliance with the instructions and values given by the documentation and marking of the unit is imperative in order to ensure a proper functioning of the brake.

2.1 - Symbols used in this manual



Action that might damage the brake.



Action that might be dangerous to human safety.



Electrical action that might be dangerous to human safety.



Handling of loads that might be dangerous to human safety.



Surface temperature that might be dangerous to human safety.

2.2 - Safety precautions for installation and maintenance



During maintenance, make sure that the driving mechanism is stopped and that there is no risk of accidental starting. The intervention must be signaled and the work area delimited.



All intervention must be done by authorized and qualified personnel, having read and understood this manual, using adapted procedures and professional tools. All intervention must be done according the regulation of the country of the installation.



All works on the electrical connections must be done with power off.



Magnetic field generated by the magnet, can create dysfunctions on near machine or device. Users must also be careful about attractions of tools or other devices during interventions.



Due to the magnetic field generated by the magnet, the bearers of a heart pace-maker or an implant must avoid the proximity of the unit.



During operation the brake surface can reach temperatures higher than 80°C. Users must be careful during contact with the unit.

Respiratory protection



Inhalation of large amounts of dust can cause coughs and difficulty in breathing.
Respirator must be worn if exposed to friction material dust. [Dust mask FFP2].
Move to fresh air in case of accidental inhalation of dusts.
In the event of persistent symptoms receive medical treatment.
In case of ingestion of friction material dust, consult a doctor.



Provide appropriate exhaust ventilation at places where friction material dust can be generated.
Do not use brushes, pressurized air or hazardous agents to clean the brake. The use of a vacuum cleaner is recommended.



Hand protection

Protective and dust-resistant gloves.



Eyes protection

Friction material dust particles, like other inert materials, may be mechanically irritating the eyes.
Safety goggles with side protection.
In case of contact with eyes, carefully rinse with plenty of water.
In the event of persistent symptoms seek medical treatment.



Skin protection

Prolonged skin contact may cause mechanical irritation.
Dust resistant protective clothing.
In case of contact with skin, wash with soap and water as a precaution.
Consult a doctor if skin irritation persists.



Feet protection

Safety shoes must be worn.



Helmet protection

Safety helmet must be worn.

Protective and hygiene measures

Do not breathe friction material dust.

Wash hands before breaks and at the end of workday.

During maintenance, do not eat, drink or smoke.

Handle in accordance with the general hygienic rules.

Remove and wash contaminated clothes before re-use.

2.3 - Precautions for handling



Avoid any impact or damage to the brake during handling.



To avoid risk of injury (see mass of the units in the service manual of the brake), use an adapted device, hoist or crane, for the handling of the unit.



When handling, use the handling holes intended for this purpose.
Never lift the brake using the coil cables.

2.4 - Precautions on use



Customer is responsible of brake qualification with his interface in order to guaranty that brake performances are not reduced.

The use of the 2 circuits in redundancy is mandatory.

This brake is designed to work in clean conditions. Friction faces must be kept completely clean of any oil, water, grease or abrasive dust.

The friction flange, on customer side, must be, also, carefully cleaned and degreased.

The friction faces must be protected, with adapted devices (cover, heating devices, etc...):

- To avoid pollution and rusting during the lifetime of the unit.
- To avoid condensation, resulting in freezing conditions, in low temperature/high humidity, or sticking of the disc.



This brake is designed to work in ambient temperature between 0°C and 40°C.



This brake is designed to work with duty cycle of 50% (Insulation class: 155°C). The temperature of customer friction flange must not exceed 90°C.



This brake can only be used on « horizontal » position.



When switching on DC-side the coil must be protected against voltage peaks, according DIN VDE0580.



Make sure the rated supply voltage is set within the tolerances, an under-voltage supply, generates a reduction of the maximum air gap.



An over-voltage supply generates additional heat on the surface of the brake, with risks of injury by burning and possible damage to the coil.



Emergency braking: for emergency braking the switching OFF must be connected on DC current side, in order to obtain short engaging time of the brake.



Service braking: for service braking, the switching OFF and ON must be connected on AC current side, in order to obtain silent switching.

2.5 - Restrictions on use



Any modification made to the brake without the express authorisation of a representative of Warner Electric, as far as, any use out of the contractual specification accepted by "Warner Electric", will result in the warranty being invalidated and Warner Electric will no longer be liable in any way with regard to conformity.



If maximum rotation speed is exceeded, the guarantee is no longer valid.



The brake must be replaced if it is submitted to water projections.



For the brake to comply with directive 2014/33/EU, the installer must observe the general conditions for installations and use as defined in the EU type certificate, drawn up by the TÜV SÜD Industrie Service (see EU-BD number in table 1), including the mandatory use of a speed limiting device, in compliance with EN 81-20 paragraphs 5.6.2.2.1 and 5.6.6.10 Under no circumstances, this device can replace the system case against the car overspeed in the descending phase.



The customer must be careful to not alter the factory set parameters: Microswitch adjustment. This brake must not be dismantled.



This brake is designed for static applications. Dynamic brakings are restricted to emergency braking and test braking.



Unless otherwise specified in the manual service, this range of product is not designed to be used according 2014/34/EU directive "Equipment for explosive atmospheres" (ATEX).

3- Storage



These devices are delivered in a package guaranteeing the preservation of the product providing it is by surface transportation.
In case of a specific request (air or sea transport, long-term storage, etc) contact our factory.

4- Technical Specification

4.1 - Brake description

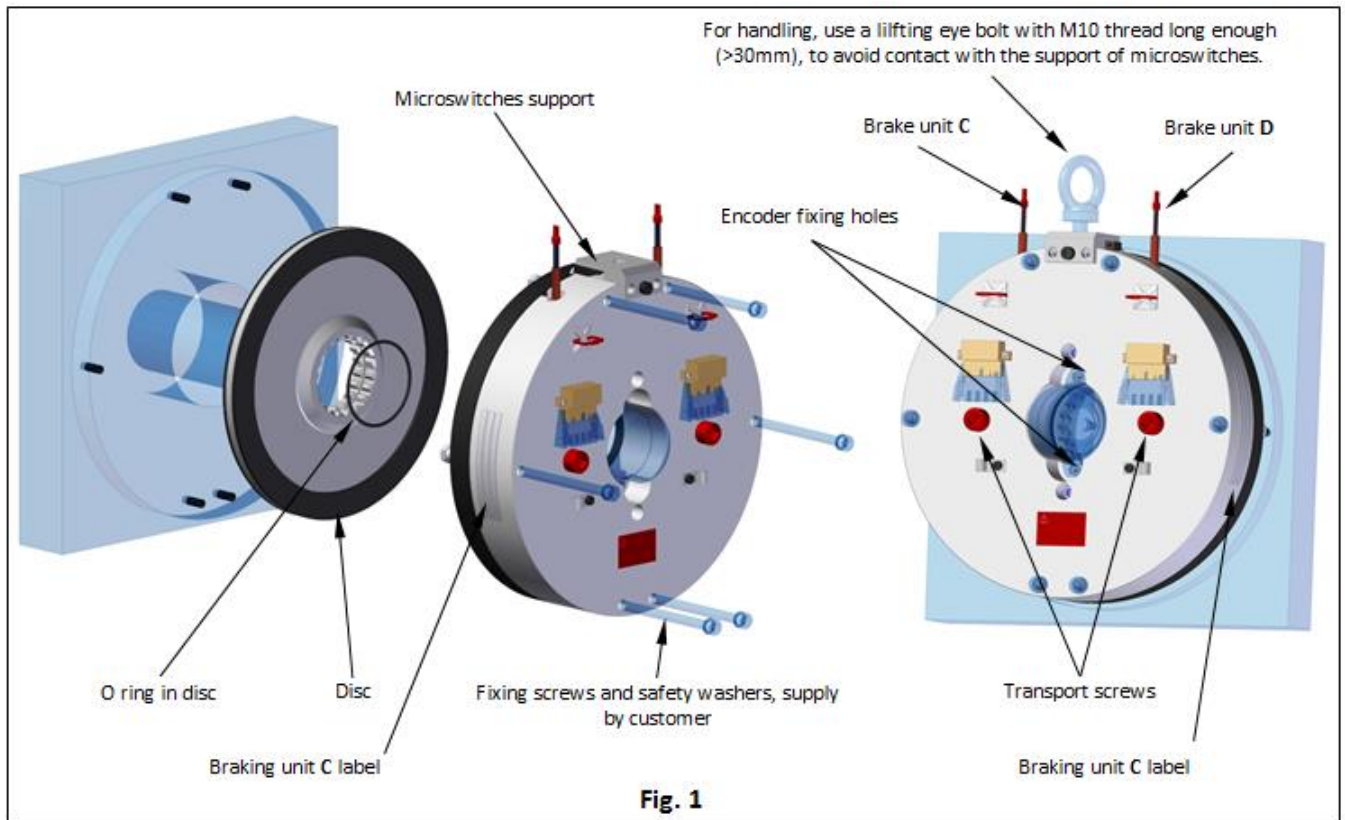

4.2 - Technical data

Table 1	ERS VAR07	
Certificate: Directive 2014/33/EU - Norm EN81-20&50 Lift Regulation 2016	EU-BD 819/2 UK-BD 819/2	
Size	SZ420/350	SZ600/550
Warner Electric Europe Part Number	30315184	30315185
Plan Part Number	1 12 107260	1 12 107261
THYSSEN KRUPP Part number	9900 000 9967	9900 000 9968

CAUTION: Use a power supply with overexcitation

Per magnet	Torque installed	Nm	350	550
	Overexcitation voltage	Vdc	103	
	Holding voltage	Vdc	72	
	Overexcitation power	Watt	132	156
	Holding power	Watt	65	74
	Resistance	Ω	80	70
Maximum speed	min-1		279	
Minimum Air gap	mm		0,3	
Maximum Air gap (after wear)	mm		0,6	
Cyclic duration factor	ED		50%	
Weight	Kg		32	42

4.3 - Labeling details

For location of labeling on brake, please refer to **Fig. 1**, page 7.

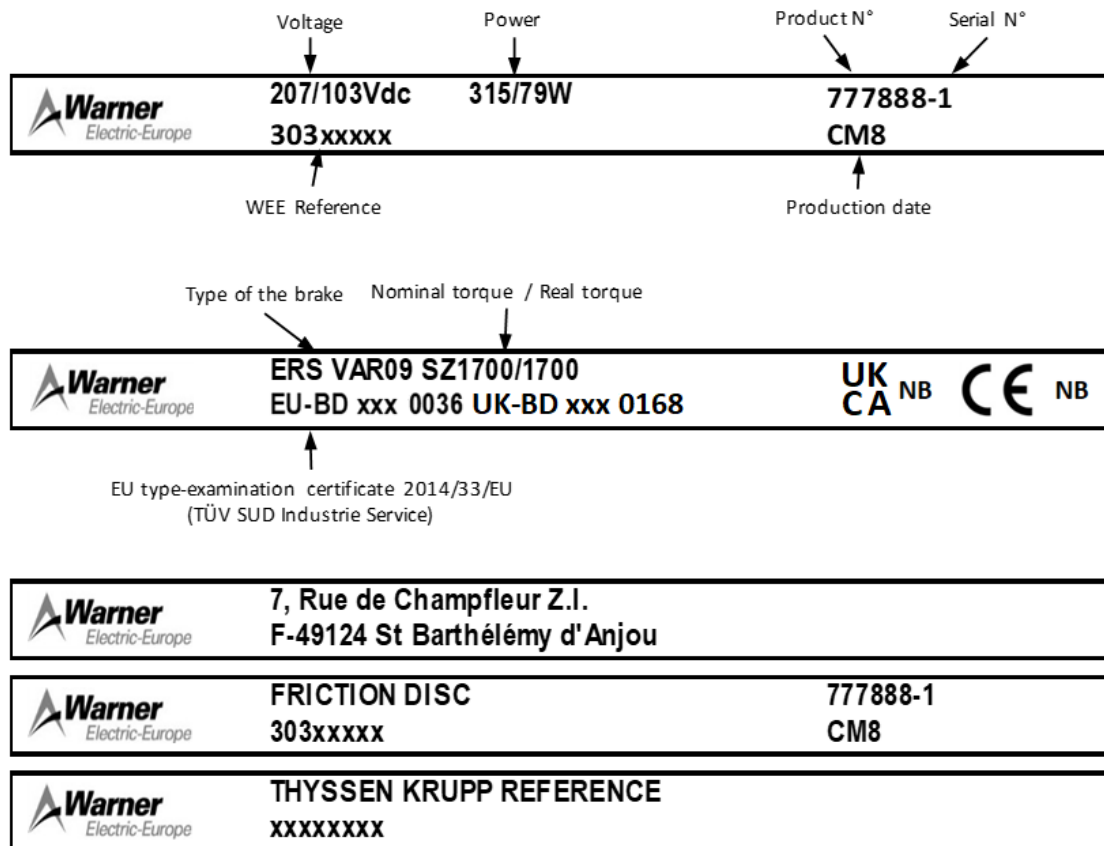

In case of presence of QR code label, here is the information contained.



Identify	Data Field
1	Product name
2	Release (NA)
3	Revision (NA)
4	Identification number
5	Serial number
6	Batch number (NA)
7	Manufacturer name
8	Manufacturer postal code
9	Manufacturer town
10	Manufacturer country code

Encoded date details:

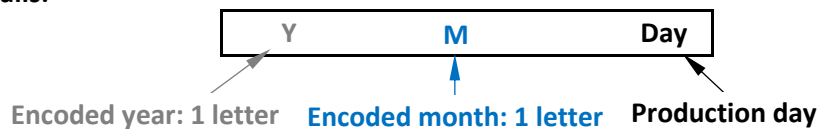

2006	2007	2008	2009	2010	2011
U	V	W	X	Y	Z
2012	2013	2014	2015	2016	2017
A	B	C	D	E	F
2018	2019	2020	2021	2022	2023
G	H	I	J	K	L

January	February	March	April	May	June	July	August	September	October	November	December
M	N	O	P	Q	R	S	T	U	V	W	X



Example: AU08 is, 2012, September 8th

5- Installation

5.1 - Customer Interface Specification

Customer friction flange specification:

- Material: Cast iron EN. GJS400 (NFEN1563)
- Roughness: $\leq Ra 3.2$
- Finishing: Dry phosphate (with manganese or zinc)
- Tolérances géométriques :

	0,1	Customer shaft axis
	0,1	

5.2 - Brake Mounting

Reminder:

Precautions and safety measures must be read before any installation or maintenance of the brake. Compliance with the instructions and values given by the documentation and marking of the unit is imperative in order to ensure a proper functioning of the brake.



Avoid any impact or damage to the brake during handling.

Never lift the brake using the coil cables.

This brake is designed to work in clean conditions. Friction faces must be kept completely clean of any oil, water, grease or abrasive dust.

The brake is delivered pre-assembled with detection, air gap and dampening system already set.

The O ring is delivered already assembled in the disc.

Fixing screws and safety washers are supplied by the customer

For the operations described below please refer to Fig. 1, page 7.

- ✓ Engaged the disc (equipped with O ring) on customer shaft.
- ✓ Put in place brake and tighten the fixing screws, (star sequence tightening, first to initial torque, final setting torque after, see Table 2).

Taille	SZ420/350	SZ600/550
Fixing screw	6 x M8	6 x M10
Pre-tightening torque Nm	11	22
Tightening torque Nm	22	44

Table 2

- ✓ Remove transport screws.
- ✓ Make all permanent electrical connections.

6- Electrical Connection



Brake **ERS VAR07** operates on a direct current supply. Polarity does not affect the brake operation.



All works on the electrical connections have to be made with power off.



Make sure that the nominal supply voltage is always maintained. A lack of power results in a reduction to the maximum air gap.



When switching on DC-side the coil must be protected against voltage peaks, according DIN VDE0580.



Emergency braking: for emergency braking the switching OFF must be connected on DC current side, in order to obtain short engaging time of the brake.



Service braking: for service braking, the switching OFF and ON must be connected on AC current side, in order to obtain silent switching.



The connecting wires must be thick enough to help prevent sudden drops in voltage between the source and the brake.

Cable length	m	0 -> 10	10 -> 20
Cross section	mm ²	1.5	2.5

Table 2



Tolerances on the supply voltage at the brake terminals: +10% / -15% (CEI 60038:2009:2009-06).

6.1 - Connector connection

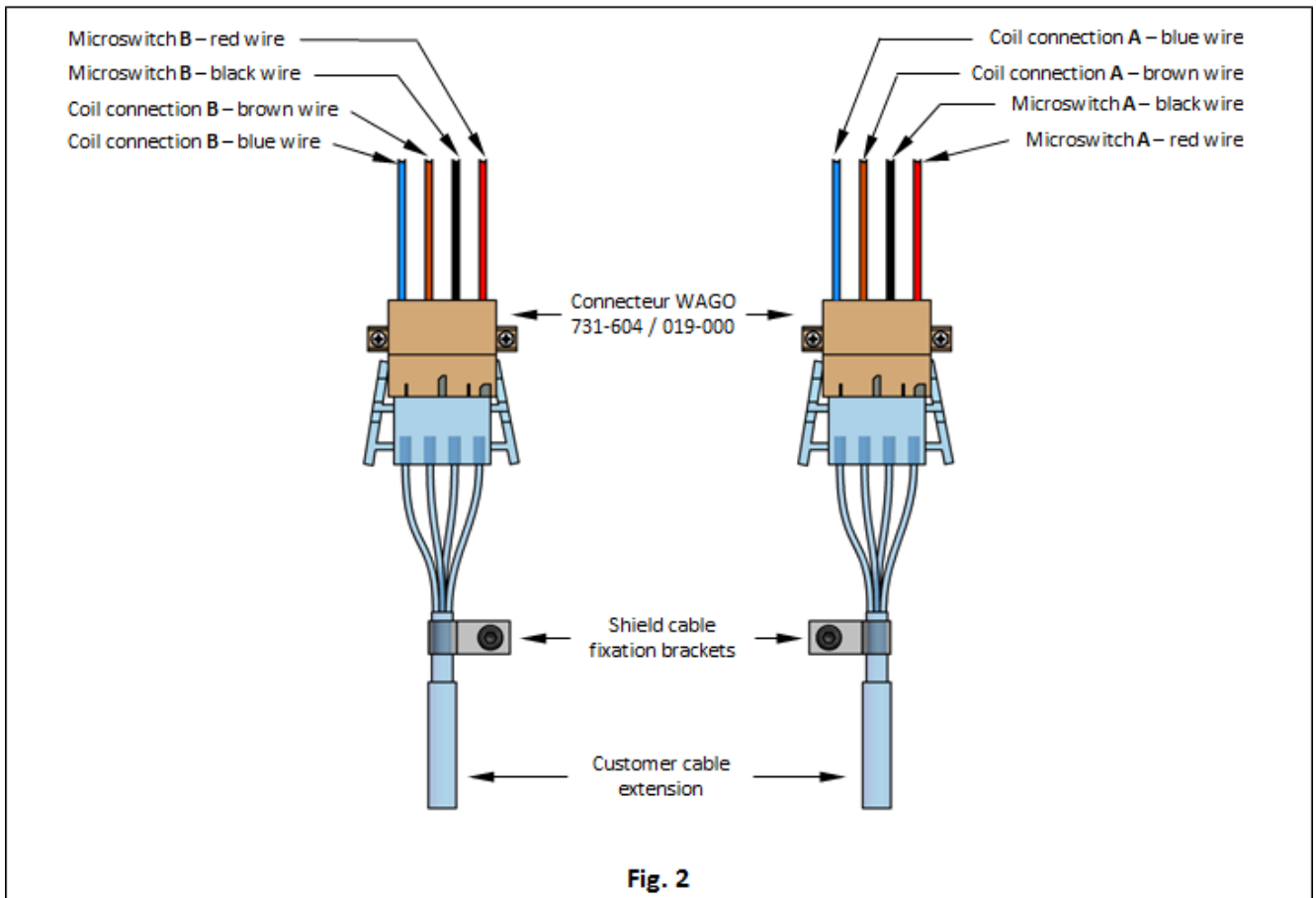

6.2 - Microswitch Technical Data

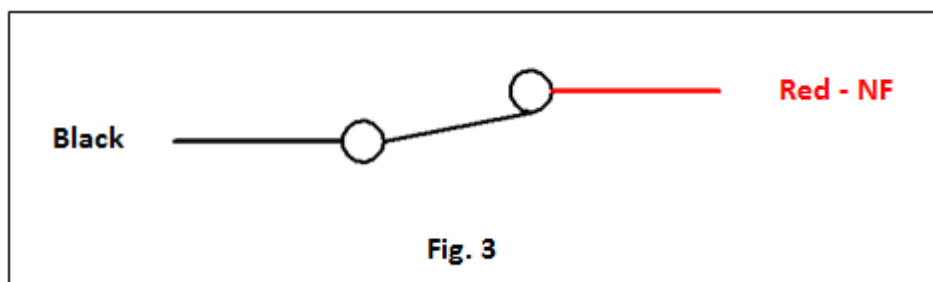

- **Current range:** 30 mA à 100 mA at 24 Vdc
- For maximum electrical lifetime of the microswitch ensure switching under resistive load only.

7- Maintenance

7.1 - Air Gap Checking



Check the air gap at each maintenance inspection.



This brake is intended for a static application as a safety brake. Any dynamic braking is restricted to emergency and test braking. Normal use will not lead to any noticeable wear on the lining. Under no circumstances, this device can replace the system case against the car overspeed in the descending phase.



Air gap has to be measured at the 3 points at the circumference and at each braking circuit (see **Fig. 4**). If the maximum value of the air gap (see Table 1) is exceeded in one point for one of the two circuits, change the disc and the O-ring.



Do not introduce the feeler gauge more than 10 mm into the air gap. Avoid the springs and the dampers of noise.



Any modification made to the brake without the express authorisation of a representative of Warner Electric, as far as, any use out of the contractual specification accepted by "Warner Electric", will result in the warranty being invalidated and Warner Electric will no longer be liable in any way with regard to conformity.



The customer must be careful to not alter the factory set parameters: Microswitch adjustment, air gap adjustment and dampening system. This brake must not be dismantled.

Location of feeler gauges per braking unit:

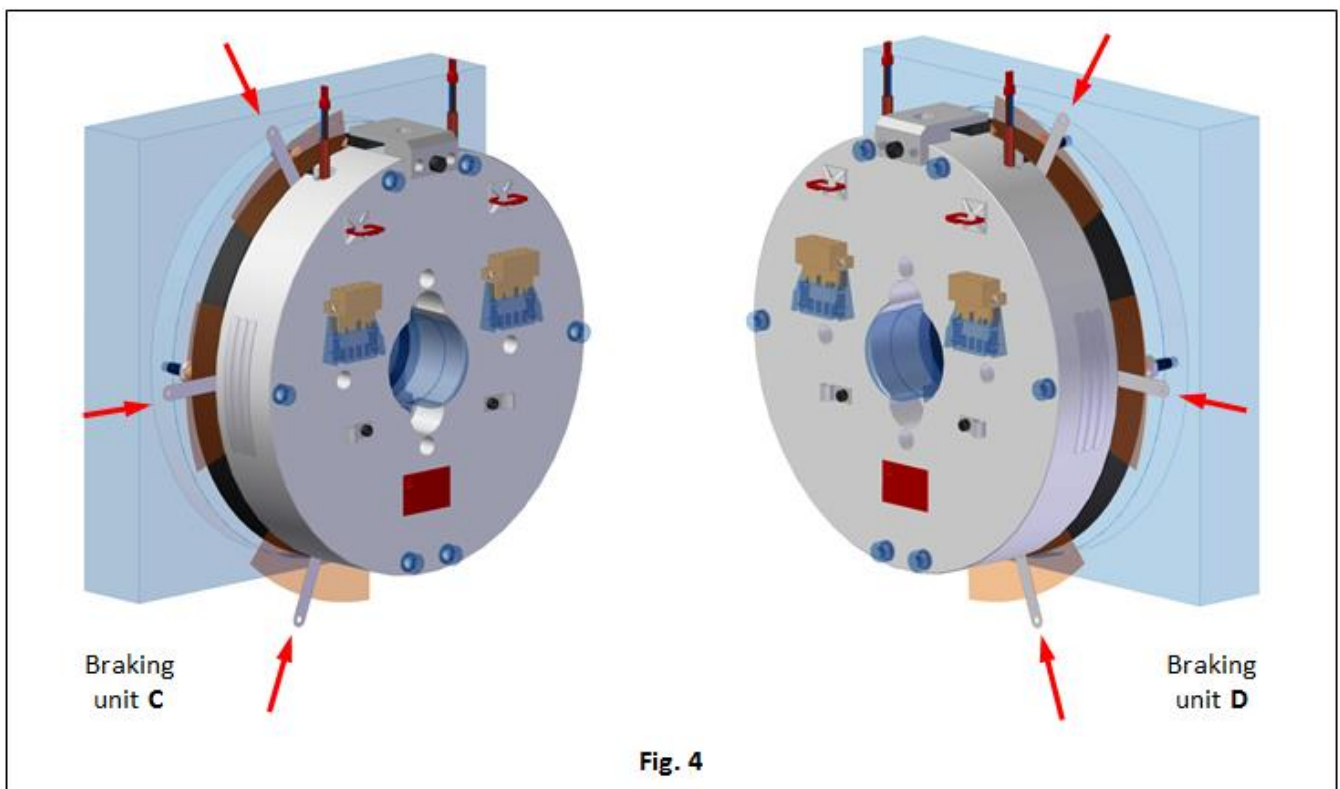

7.2 - Discs exchange



During maintenance, make sure that the driving mechanism is stopped and that there is no risk of accidental starting. The intervention must be signaled and the work area delimited.



All intervention must be done by authorized and qualified personnel, having read and understood this manual, using adapted procedures and professional tools. All intervention must be done according the regulation of the country of the installation.



Warning: It is mandatory that disassembling and assembling of the encoder is done according the instructions of the drive manufacturer.



Warning: not to damage the electric cables during the maintenance action.



This brake is designed to work in clean conditions. Friction faces must be kept completely clean of any oil, water, grease or abrasive dust.
Customer friction flange must be also carefully cleaned.

For the operations described below please refer to Fig. 1, page 7.

- ✓ Disconnect the brake electrically.
- ✓ Remove fixing screws.
- ✓ Remove braking units and disc.
- ✓ Clean the friction faces (on brake and flange) with clean and dry cloth.
- ✓ After the replacement of disc and O ring, re-assemble the brake as it is described in chapter 5-2.

7.3 - Detection Checking



Any modification made to the brake without the express authorisation of a representative of Warner Electric, as far as, any use out of the contractual specification accepted by "Warner Electric", will result in the warranty being invalidated and Warner Electric will no longer be liable in any way with regard to conformity.



The customer must be careful to not alter the factory set parameters: Microswitch adjustment, air gap adjustment and dampening system adjustment. This brake must not be dismantled.



If the installation is showing a default on the microswitch function, please start by readjusting the microswitches according to Chapter 7.4. If, despite the adjustment, it is not possible to get a correct setting, please replace the switch sub-assembly according to chapter 7.5.

For the operations described below please refer to Fig. 5 below.

- ✓ Insert a feeler gauge **0.15 mm** thick as it is shown in Fig. 5.
- ✓ Switch ON the brake; the state of both microswitches must change.
- ✓ Switch OFF the brake.
- ✓ Insert a feeler gauge **0.20 mm** thick as it is shown in Fig. 5.
- ✓ Switch ON the brake; the state of both microswitches must not change.

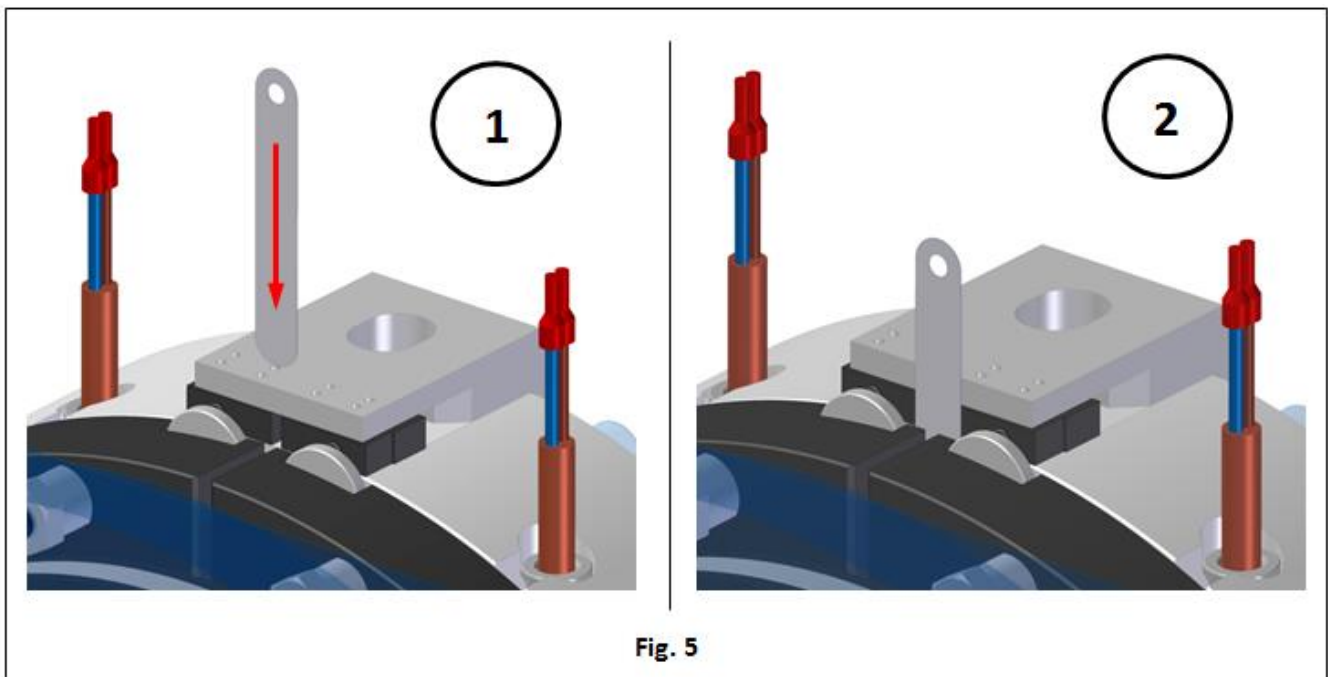
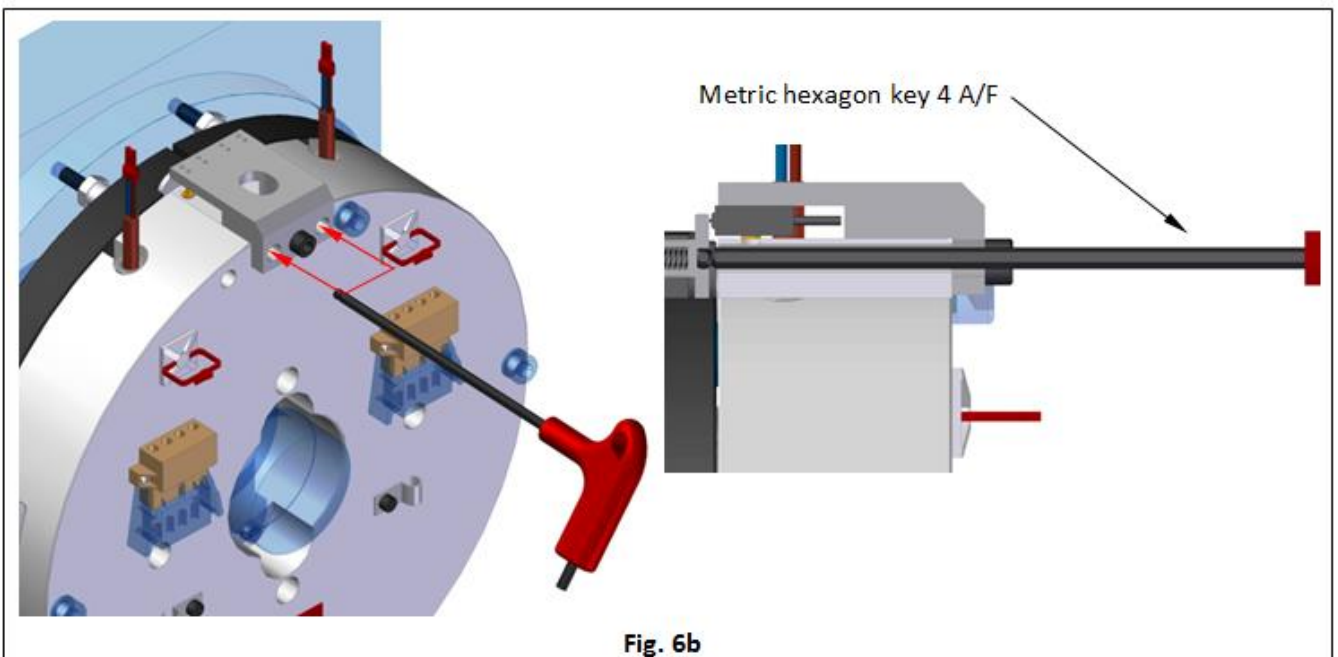
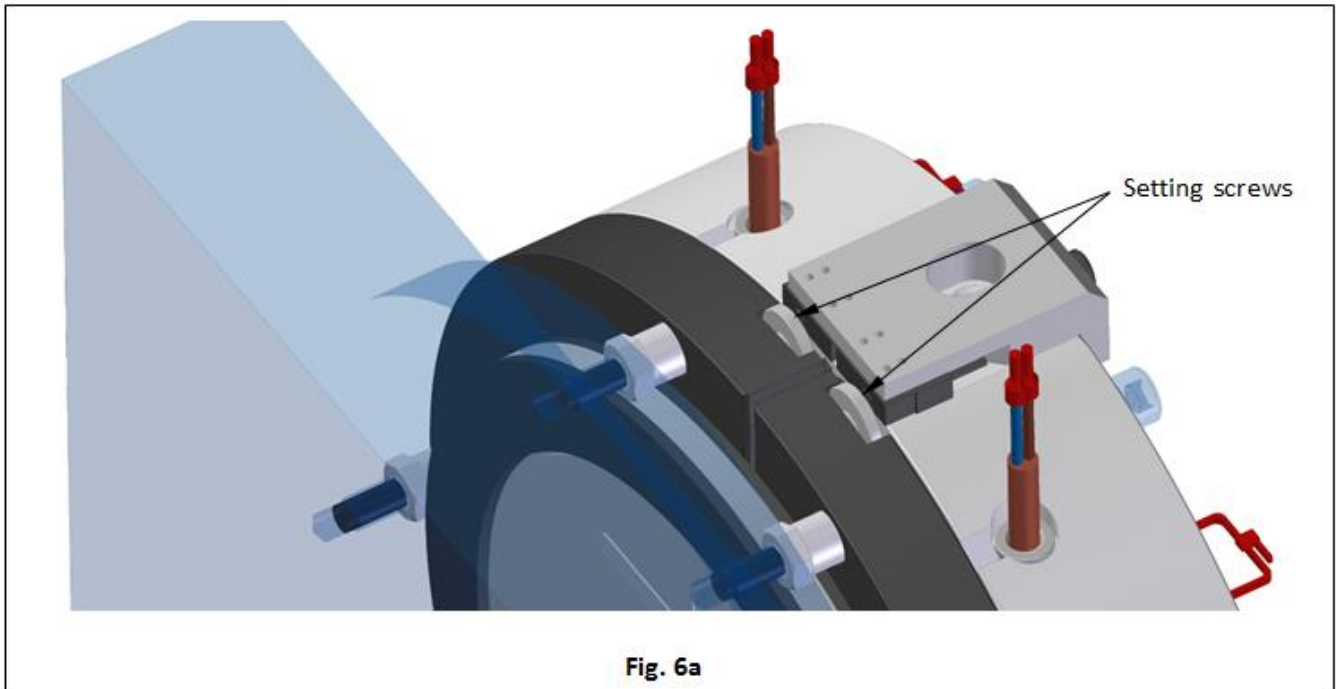

Fig. 5

7.4 - Detection setting

For the operations described below please refer to Fig. 5, page 14 and Fig. 6a and Fig. 6b below.

- ✓ Insert a feeler gauge **0.20 mm** thick as it is shown in Fig. 5.
- ✓ Switch ON the brake and adjust the setting screw (Fig. 6a & 6b) until to obtain detection.
- ✓ Re-tighten carefully the setting screw until to have no detection.
- ✓ Switch OFF the brake and perform **3** detection checking as it is described in chapter **7-3**.



7.5 - Microswitch exchange



During maintenance, make sure that the driving mechanism is stopped and that there is no risk of accidental starting. The intervention must be signaled and the work area delimited.



All intervention must be done by authorized and qualified personnel, having read and understood this manual, using adapted procedures and professional tools. All intervention must be done according the regulation of the country of the installation.



Warning: not to damage the electric cables during the maintenance action.

For the operations described below please refer to Fig. 8, page 17.

- ✓ Remove microswitches wires from connectors, see Fig. 2, page 11 & Fig. 7 below.
- ✓ Untighten and remove microswitches support fixing screw.
- ✓ Replace microswitches support and re-tighten fixing screw.
- ✓ Ensure that the new support is completely in contact on both surfaces.
- ✓ Re-connect microswitches wires into connectors.
- ✓ Perform detection checking as it is described in chapter 7-3.
- ✓ If the detection checking fails, perform a detection setting as it is described in chapter 7-4.

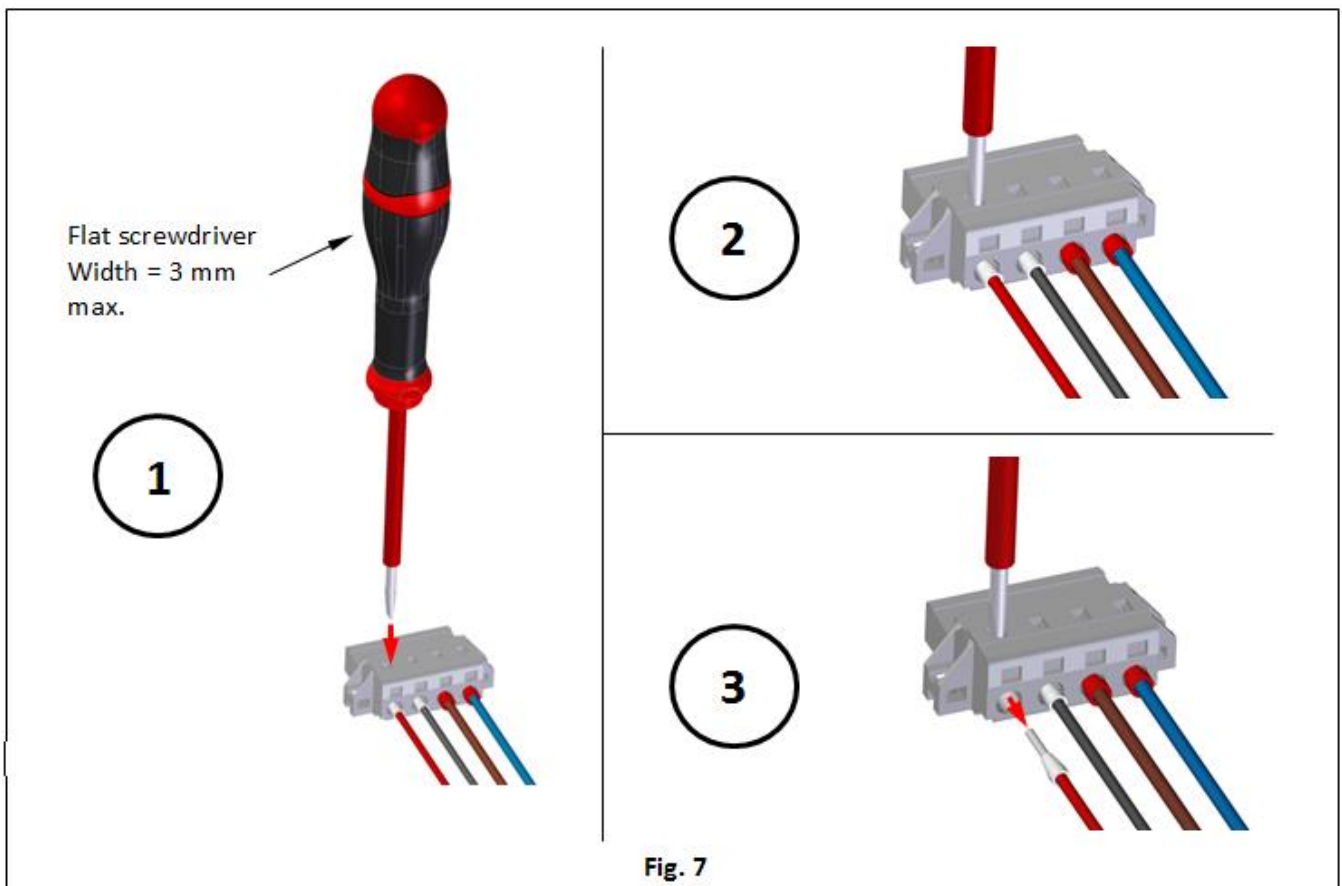

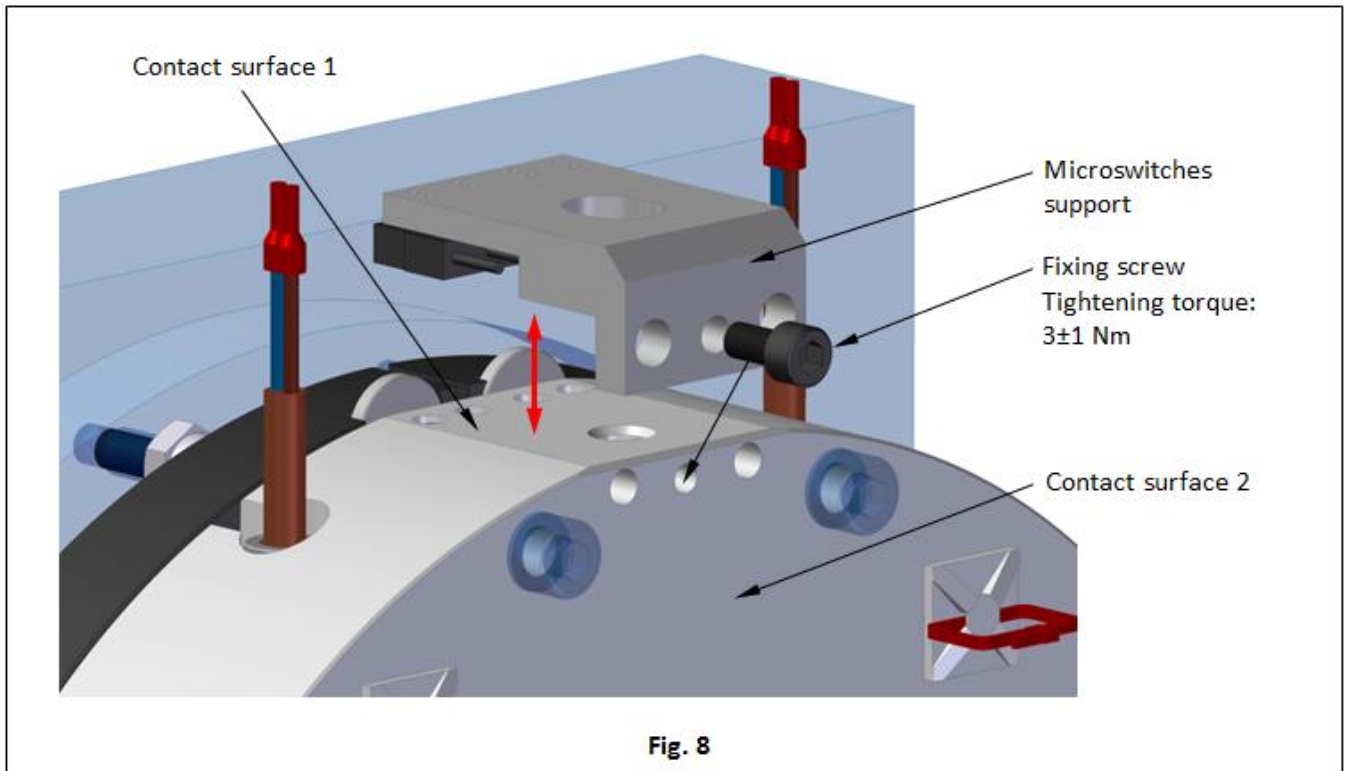

8- Spare parts

Available spare parts for this brake are the following:

- Disc
- ring (to put into the disc)
- Microswitch

Please, join to your spare part request the following information:

• Warner Electric Europe Reference
• Production Number
• Serial Number
• Production Date

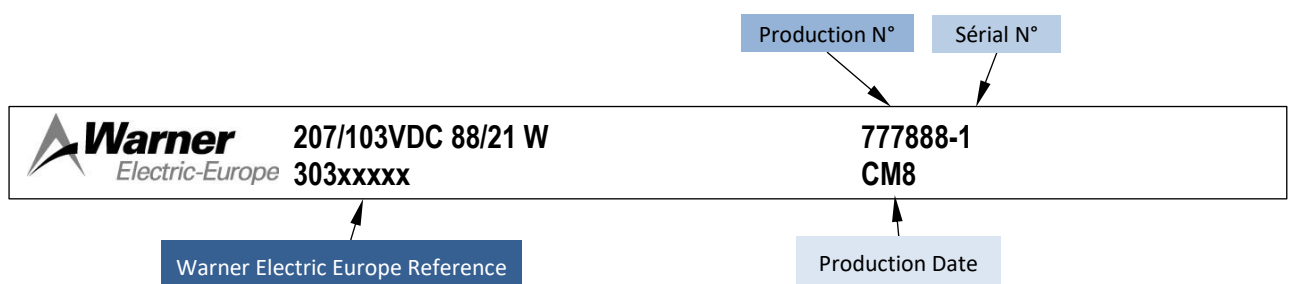

9- Tooling

Tooling	Function
Torque wrench (measurement range > 50 Nm)	Brake fixing screws
Feeler gauges play	Air gap checking Detection checking Detection setting
Metric hexagon key 4 A/F (lg mini = 80 mm)	Detection setting
Metric hexagon key 5 A/F	Microswitch exchange
Flat screwdriver (Width=3mm max.)	Microswitch exchange
Multimeter	Voltage checking

10- Troubleshooting

Troubleshooting		
Fault	Fault	Fault
Brake does not release	<ul style="list-style-type: none"> • OEX time too short • Voltage too low • Power supply is interrupted • Air gap too large • Disc worn • Coil damaged 	<ul style="list-style-type: none"> • Re-set OEX time • Re-set voltage • Re-connect the power supply, check detection • Replace disc and O ring • Replace disc and O ring • Replace the braking unit
Brake does not brake	<ul style="list-style-type: none"> • Voltage present at switch off Position • Grease on friction faces • Transport screw still in place 	<ul style="list-style-type: none"> • Check detection and customer power supply • Clean the friction faces, change disc and O-ring • Remove transport screw
Nuisance braking	<ul style="list-style-type: none"> • Holding voltage too low • Wrong information from microswitch 	<ul style="list-style-type: none"> • Re-set voltage • Re-set detection
Brake vibration under holding voltage	<ul style="list-style-type: none"> • Bad electrical connection (incorrect polarity) 	<ul style="list-style-type: none"> • Check the good connector connection configuration (chapter 6-1).

11- Contact

Any question? You can contact us at: info@warnerelectric-eu.com

This translation is for information only. In case of discrepancy between this version and the original in French, only the text of the French version prevails.

All rights reserved to change without prior notice