

3

VISION



2D



Sill Light



BPL



Adapt 3

VS3 1447

Product Guide
and
Installation Instructions

PRODUCT OUTLINE

PLAN VIEW

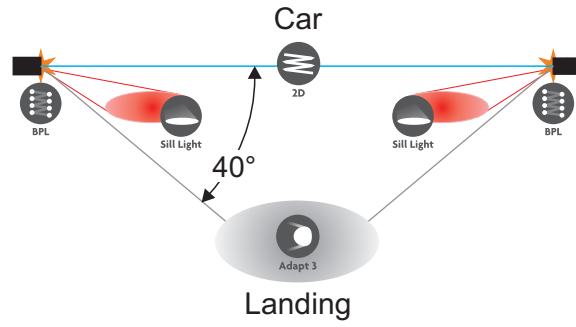

ENTRANCE VIEW

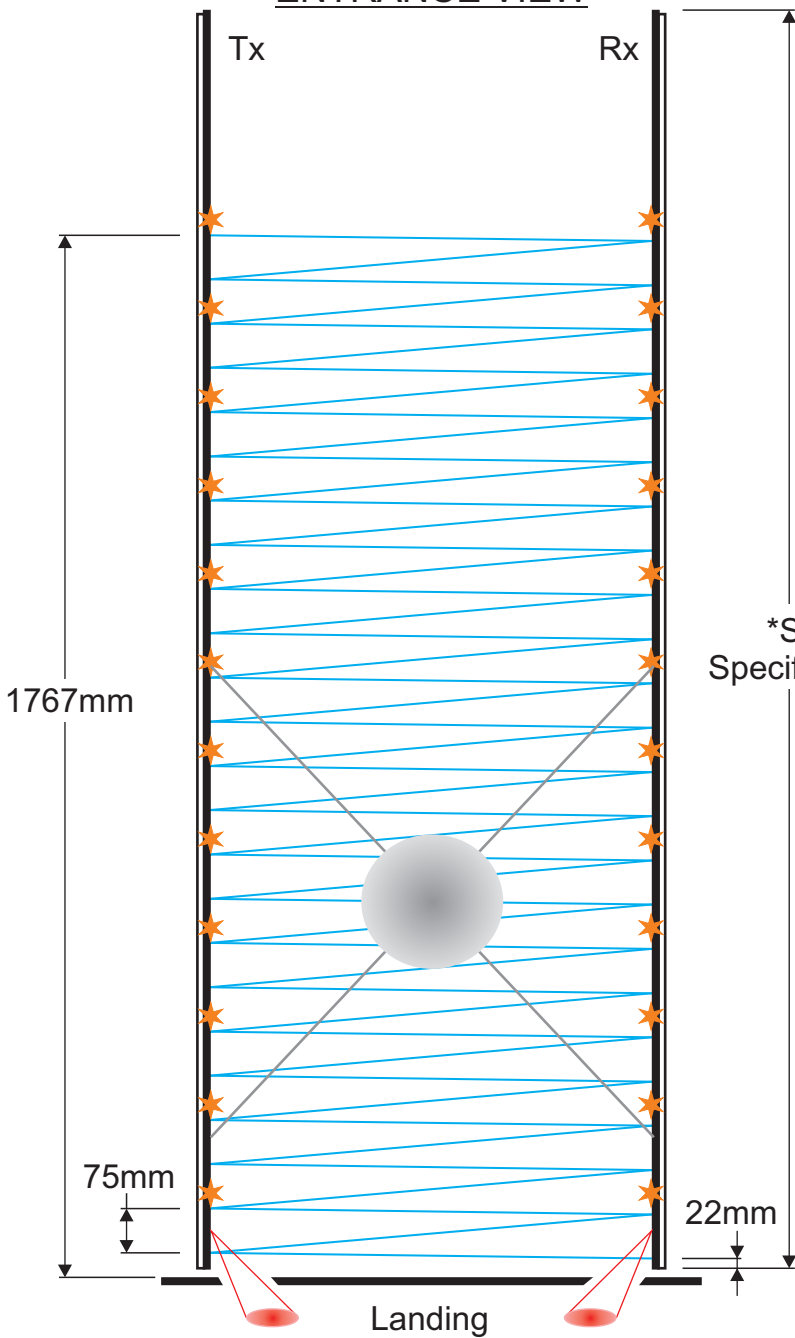

Door Mount Configuration

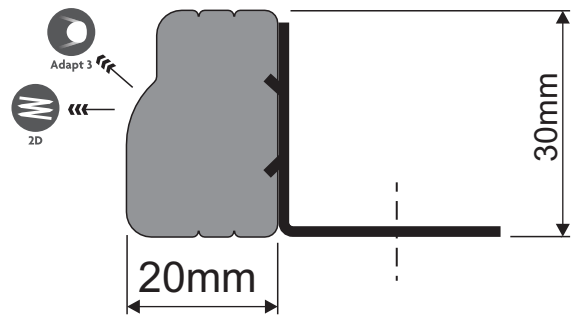

*See Specification

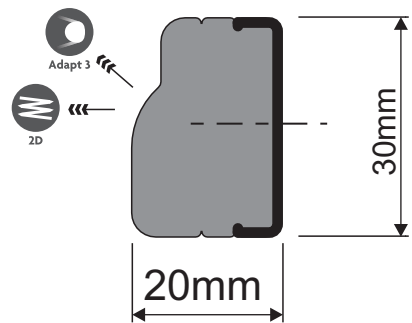

Slam Mount Configuration



Introduction Vision Series

The Vision series is an entirely new range of elevator door light curtains and combine the recognised standard 2-dimensional curtain functions, with several new enhancements. The design is based on existing architecture. The 2D beam technology has its roots in the FCU0547 whilst the serial communication protocol used to facilitate the enhanced features has its heritage in the original SafeZone 3D although this has been upgraded for the Vision range.

The core features that define the Vision 3 series are:

-  Sill Light
-  Beam Path Locator (BPL)
-  Adapt 3.

Sill Light

At the core of every Vision is Sill Light, a flashing Red LED that is intended to draw passenger attention to the sill area, also highlighting any unintended variation and potential trip hazard. Sill Light illuminates upon door opening in its default mode, or after a pre-determined time delay of up to 6 seconds, invoked by the adapted module.

The flashing LED is coloured Red to provide contrast with typical sill materials, as well as providing a noticeable stimulus in order to attract passenger attention. The Sill Light can work independently or in conjunction with both BPL and Adapt 3.

Beam Path Locators (BPL)

BPL is an illumination system designed to highlight the source and destination of Vision's invisible infrared detection beams. The intention of BPL is to guide passengers towards door detection points, thereby assisting the passenger in using the door detector as a door open switch.

The illuminating LEDs are Amber in colour, selected because Amber is typically accepted as a visual code for passengers to proceed with caution, with the time and nature of the illumination suggesting varying degrees of hazard.

In its basic default condition, doors will open with the BPL inactive. After 4 seconds the BPL array begins to flash at the slower of two rates, speeding up at a time anticipated to coincide with imminent door closing.

The enhanced function provided by the adaptor module can be used to either select different timing from those of the defaults, or alternatively to control activation should a suitable door control input be available e.g. the door close button or controller signal.

Adapt 3

As an all new forward-facing proximity sensor system, Adapt 3 has been optimised for both simplicity and effectiveness. Adapt 3 provides high-performance detection capability suitable for all traffic applications including hospitals, airports and hotels, where load-laden passengers, luggage carts, chairs and patient beds represent a more complex detection challenge than that faced by a typical passenger elevator. Using a combination of twin sensor sets per edge, the Adapt 3 system optimises target detection by identifying general approaching traffic when the doors are wide open and near-field objects when the doors are almost closed. Adapt 3 is offered as a standard feature on Vision 3 models only.

Connectivity

As with previous Formula Systems products Vision is a 'controller-less, direct-connect' design, suitable for direct integration with most door operators and controllers.

Basic connectivity simply requires a suitable low voltage supply (18-30v DC), and produces an NPN (normally closed) control signal input switched to ground.

Vision can be connected to the all existing universal interfaces such as FPS0270 and FPS0271 and 274 making retrofit to an FCU47 installation an easy installation upgrade step.

A new interface, FPS0279 can extend the capabilities of the Vision series with additional selectable options and input controls and a universal power input.

Eco-mode

Formula Systems have incorporated a simple energy-saving feature in the Vision range. By reducing the number of active beam paths when the doors are closed power consumption is reduced by 30%. As doors begin to open, Vision senses the change and immediately returns the system to full detection capability.

Installation - Vision 3

The installation kit includes the following:

Item	Quantity	Usage
Slam Mount extrusion	1	
Bracket Door Mount	10	
Cable Retainer	2	
Cable Extension	1	Extends cable (side opening)
Screw No 6 x 10 Flange PZ	3	Slam Mount extrusion
Washer M4 Plain	12	
Washer M4 External Toothed locked	12	
'P'Clip Size 7.9 Natural White	10	
Screw M4 x 20 Pan PZ	12	
Screw 4.8 x 13 Hex Washer Self Drill	10	Bracket to door
Drill 3.6mm HSS S/S Jobber	1	
Screw M3 x 6 Pan PZ	10	Bracket to edge

Centre opening

Unlike a simple 2D system the Vision edge is handed, the Tx and Rx must be installed (shown in the diagram below) with the Tx on the left hand side when facing into the car and the lens profiles curved toward the landing to facilitate good transmission angles for VS3 features.

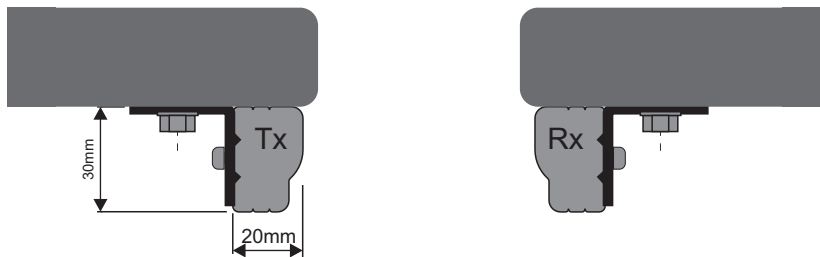

Install the Tx and Rx edges onto the doors using the mounting brackets using 5 on each edge spaced at regular intervals or as convenient if existing hole positions exist. The brackets slide into the channel from the top. Slide in all 5 before beginning to position, secure and tighten fixings

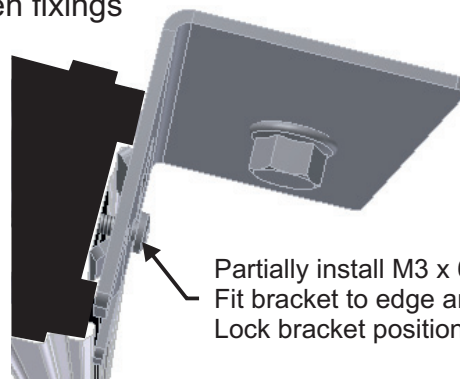

Partially install M3 x 6mm thread forming screw to bracket.
Fit bracket to edge and position.
Lock bracket position using jacking screw (as shown).

Side opening

The light curtain now has a simple snap-in clip extrusion for static slam positioning. Mark the slam using the edge on the door as a guide to ensure the slam unit is as well aligned as possible to the unit on the door anything that looks aligned to the eye will be satisfactory with 0.25" offset in any direction being a practical preferred limit.

Secure the plastic slam extrusion at points $\frac{1}{4}$, $\frac{1}{2}$ and $\frac{3}{4}$ along it's length using the flanged pozidrive screws along a centre line of the piece (the ends will be secured later).

Press the respective edge into the extrusion, starting at one end (the bottom is easiest) and working along until the edge is fully snapped in (a second pass may be required to ensure all points are fully home). To complete a secure installation it is recommended to then remove the lens cover of the edge and secure at top and bottom mounting points with the screws provided

Cord routing

Correct cord routing is essential for long service life and trouble free operation. The cord must be installed such that all bending during door movement happens in the 'hanging loop' and not at the anchor points. See below and note 'P' clips used to secure cord..

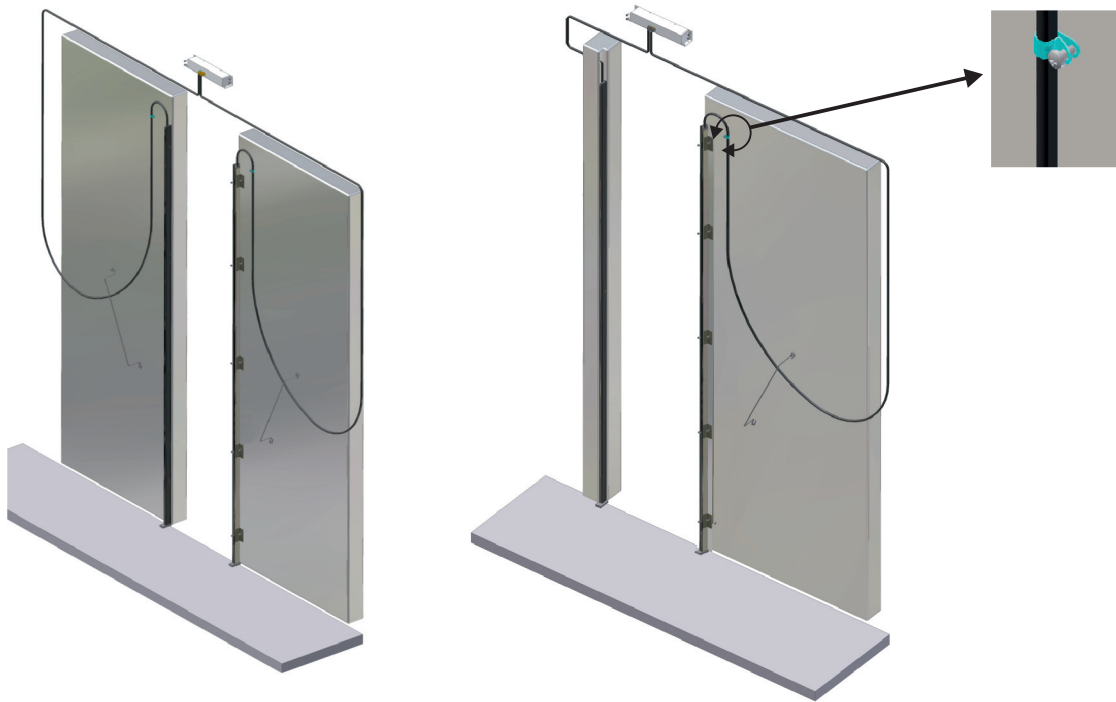

Connections

Conductor colours are:

Brown	-	24V	(18-30v)
Blue	-	Common,	(Connected internally to ground)
Black	-	Signal output	(NPN normally closed)
Yellow	-	Data	(links RX to Tx)

Connect the Rx and Tx edges to the Vision interface unit (FPS 0279) as shown below:

Connection to a standard FPS units is possible using an optional cable assembly (see below).

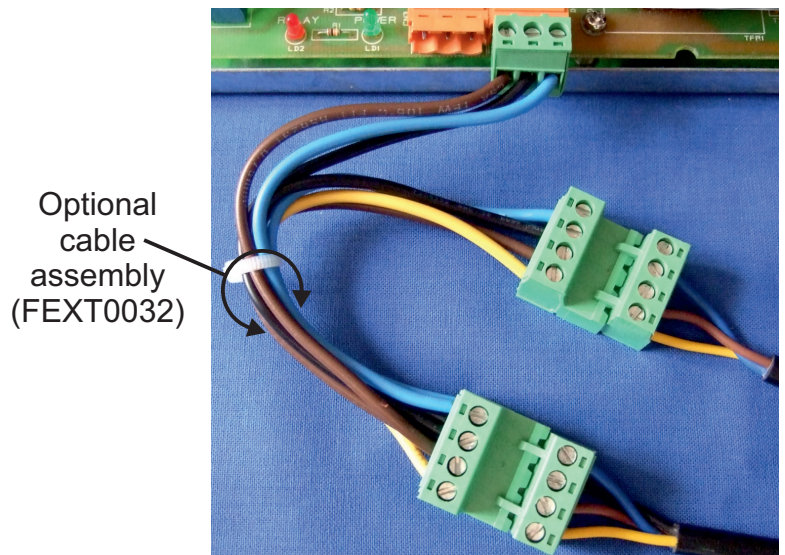
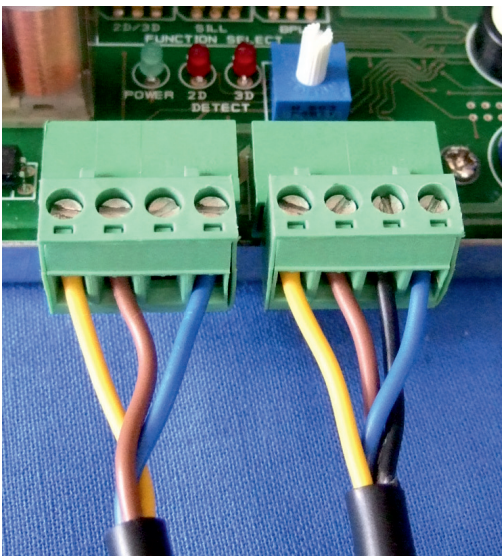

Commissioning

Factory settings are as follows:

- Rx and Tx SILL light - ON
- Rx and Tx BPL - ON
- Adapt 3 ON and set to High sensitivity

2D protection is permanently active.

Configurable feature	Options	Switch location
Tx SILL Light	ON/OFF	Tx edge
Tx BPL	ON/OFF	Tx edge
Rx SILL Light	ON/OFF	Rx edge
Rx BPL	ON/OFF	Rx edge
Adapt 3 sensitivity	High/Low	Rx edge
Adapt 3 master control	ON/OFF	Rx edge

Testing

Switch on the power and park the doors in the fully open position.

The red SILL lights on the bottom of each Rx and Tx edge should immediately start flashing. Shortly afterwards the amber BPL indicators will also start flashing. The open loop mode will anticipate a typical door cycle and the flash rate of the BPL will increase in association with the door closing.

Check the function of the 2D beams by obstructing each or a substantial number across the height of the door. If the edge detects the obstructed beam the LED on the Rx edge will illuminate. This is best carried out by standing inside of the car to avoid the possibility of triggering the Adapt 3 proximity sensor.

Whilst the doors are still open the Adapt 3 can also be tested by approaching the doors with suitable target moving body or cart. The detection 'Hot spot' is arranged to be in front of the mid point of the entrance and forward of the sill line by an amount approximately equal to half the entrance width and centred about a point 2' from the floor. Detection by the adapt 3 system will also be indicated by the red LED on the Rx edge.

Adapt 3 will deactivate after 3 detections unless the 2D beams are also subsequently blocked. This is an anti nuisance and traffic optimisation feature.

Once these test have been carried out the doors can be moved towards closing. A distance measuring system will trigger a change in system behaviour as the doors pass a point approximately 1' from closed. Adapt 3 will be automatically overridden and the BPL and SILL illumination will switch off after a couple of seconds. In normal operation with doors at powered speed this will correlate to the door closed position. The system will also then enter Eco mode.

VS3 1447 DIP Switch control configuration

To access the switches to configure the VS3 1447, remove one or both lens filters from the front of the Tx and Rx edge. This is best achieved by prising free one top corner

Transmitter Unit (Tx) Receiver Unit (Rx)

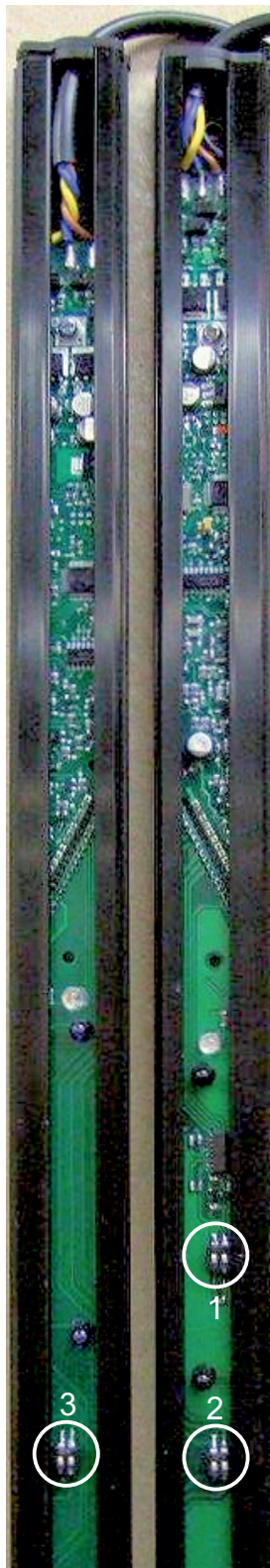

1: Adapt3 Control
Switch 1 ON = Low Sensitivity
Switch 1 OFF = High Sensitivity
Switch 2 ON = Disable
Switch 2 OFF = Enabled

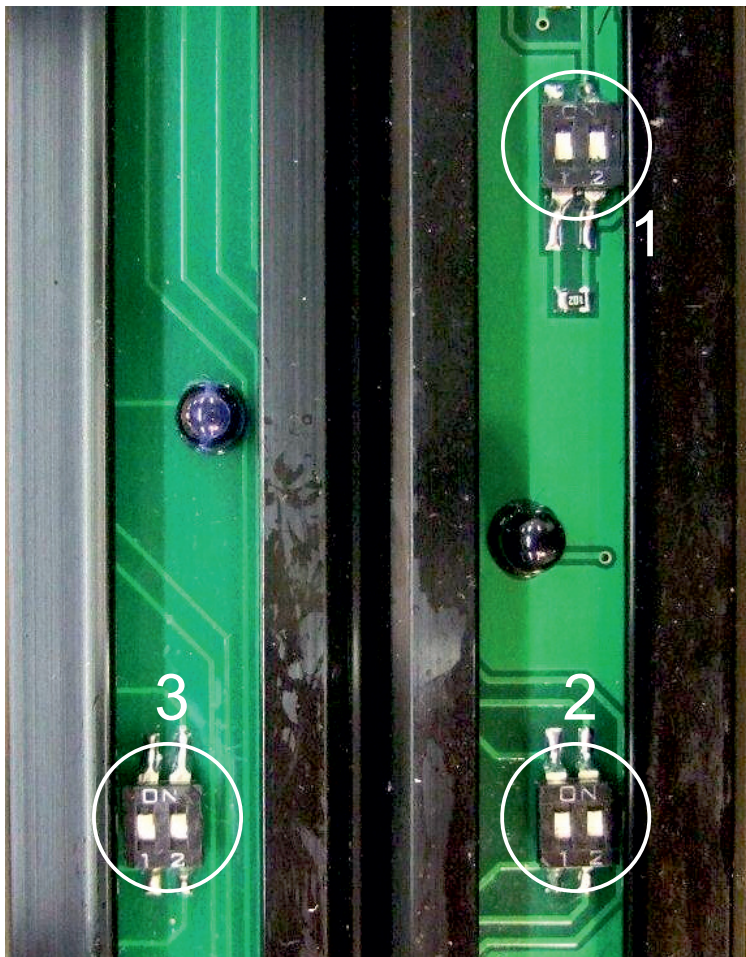

2 & 3: Both Rx and Tx have SILL light and BPL master controls. Switch 1 controls SIL and switch 2 controls the BPL light. Each can be turned on or off as required.
The default delivery settings have both set to the on positions

Trouble shooting.

Beyond the typical trouble shooting used for 2D edges there are 3 key points to double check should unanticipated behaviour be experienced.

DC Power

Both edges need to be connected and powered for each edge to function correctly. With only one edge connected a random sequence of illumination may be observed. Consequently ensure both edges are connected and that between 18 and 30V can be measured on the edge connectors between brown and blue wires. Although the connectors are a snap fit it is prudent to observe the best practice of using 'P' clips either side of the connectors to ensure continued connection.

Data Connection

The data connection (yellow wire) between Rx and Tx edge must also be connected for correct operation. If it has been disconnected for any reason be careful to check that it has been reconnected correctly. Both yellow wires should be in the **SAME** terminal of the 2-way block unless the connector is plugged into an FPS279 in which case the internal connection allows both possibilities to function.

Orientation

Although unlikely it is possible to install the edges with both facing into the car rather than out towards the landing. This would result in the SILL light pointing into the car and the adapt 3 would also be biased in the wrong direction and partially shrouded by the car door.

