

VF7+ Relay Electronic Module

VF7+ Relay Electronic Module Instructions

0 List of content

1 Scope of the document.....	3
2 Modification register.....	3
3 Connection.....	4
4 Inputs/Outputs.....	5
5 Graphic Interface.....	8
6 Installation process.....	25
7 Power failures.....	26
8 Lift standard EN 81-20.....	27
9 Reference data.....	28
10 Annex 1.....	31
11 Annex 2.....	34
12 Annex 3.....	35
13 Annex 4.....	37

1 Scope of the document

The aim of this document is to explain the operation of the VF7+ Relay.

2 Modification register

Date	Version	Description
31/10/18	0.0	New Document.
15/11/18	0.1	Update of the software version V7.01.07-00.
13/12/18	0,2	Update of the software version V7.01.08-00.
08/02/19	0,3	Update of the software version V7.01.08-01.

3 Connection

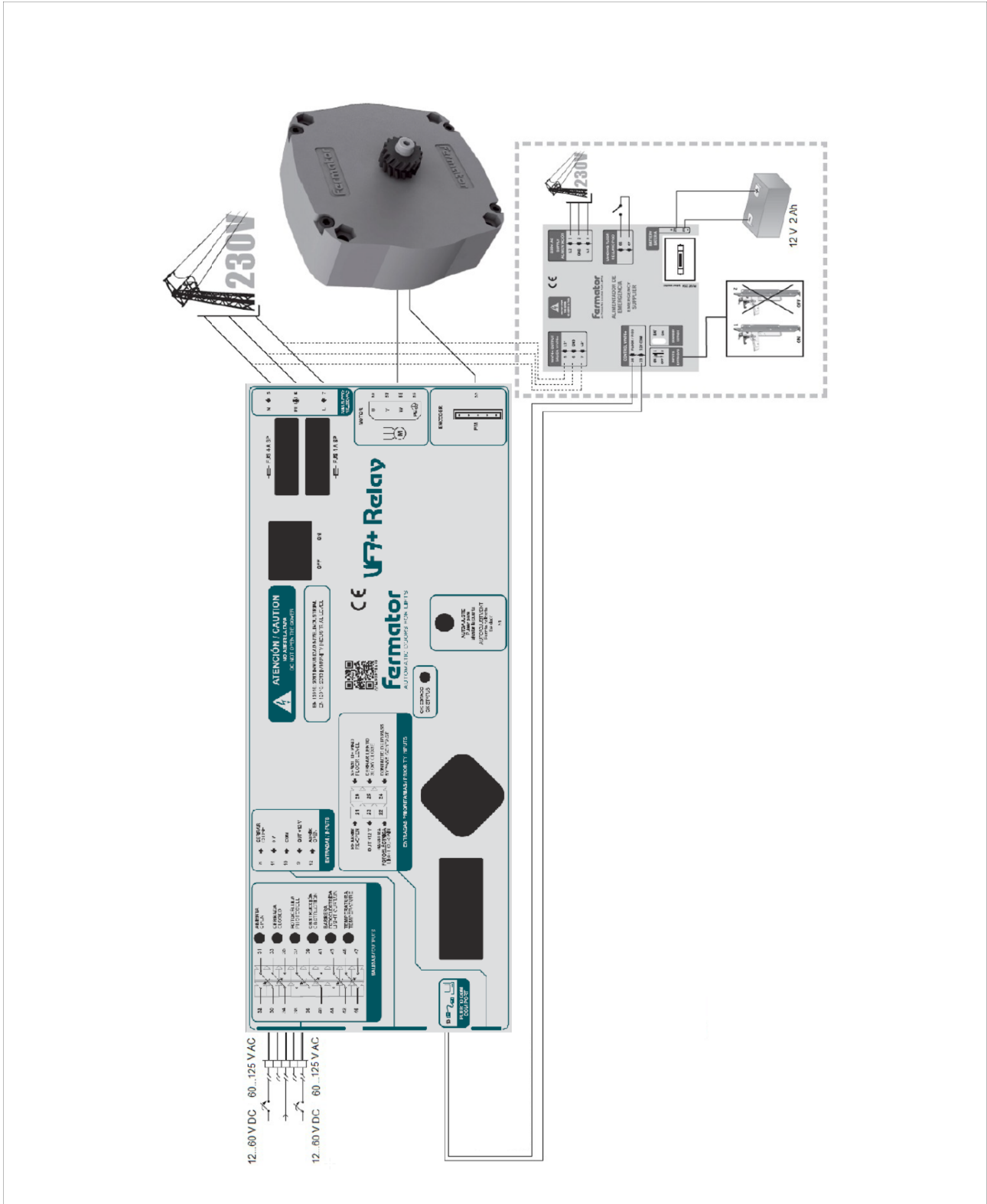

INSTRUCTIONS

DOC-FE.IE.IN.Draft.EN

VF7+ Relay Electronic Module

Version: 0.3

4 Inputs/Outputs

4.1 Power Supply (5, 6, 7)

The circuit has been designed to operate with a main supply of 230 V AC (+10%, -15%, 50 or 60 Hz).
The VF7+ Relay incorporates a soft-start system to control the bulk capacitors charge and prevent short circuits.

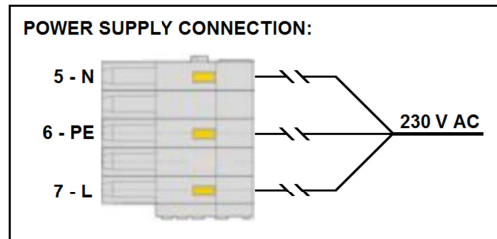

Note: It is important that the Door Operator Module has a good earth connection.

4.2 Inputs (8, 9, 10, 11, 12)

The circuit can work with external voltage inputs or internal voltage input (voltage free contact).

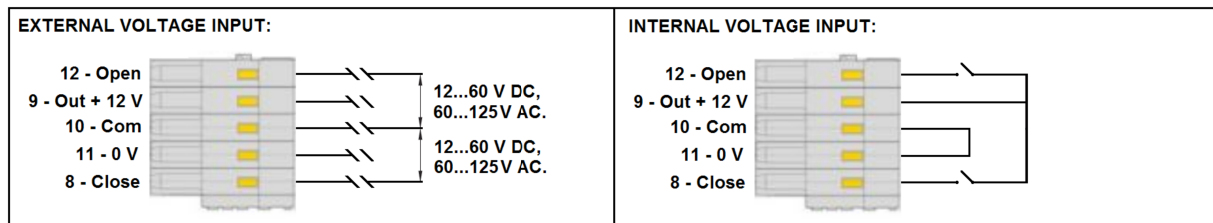

- 8.- **Close signal**
This signal is used for ordering the door to close. With an external voltage input the voltage required can be from 12 V DC to 60 V DC or 60 V AC to 125 V AC between this input and common (10).
Note: For other values contact Fermator aftersales.
With an internal voltage input the voltage provided is 12 V DC between this input and Out +12 V (9).
- 9.- **12 Volt**
Isolated 12 Volts output available to control the door through a voltage free contact.
Features are:
a) This supply must only be used for this purpose.
b) This contact must be isolated from any other power supply.
- 10.- **Common**
Is the reference used for the opening and closing signal.
- 11.- **0 Volts**
Is the opposite pole to 12 V, in the case of using internal voltage it should be connected to common input.
- 12.- **Open Signal**
Is a signal that orders the door to open. With an external voltage input the voltage required can could be from 12 V DC to 60 V DC or 60 V AC to 125 V AC between this input and common (10).
Note: For other values contact Fermator aftersales.
With an internal voltage input the voltage provided is 12 V DC between this input and Out +12 V (9).

4.3 Com Port (13)

The serial port is used to connect with external devices, interfaces and future expansion devices.
Operating speed 1.200 Baud per second, current loop.



INSTRUCTIONS

DOC-FE.IE.IN.Draft.EN

VF7+ Relay Electronic Module

Version: 0.3

4.4 Priority Inputs (21, 22, 23, 24, 25, 26)

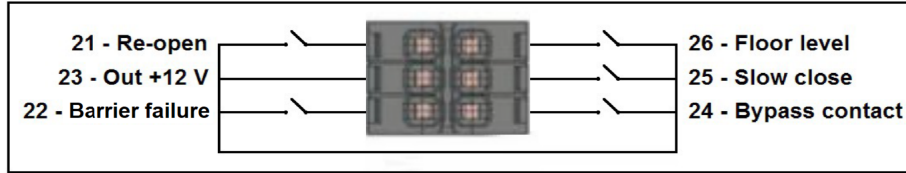

- 21.- **Reopen**
This signal may be used to connect the cabin "door open" button, an external barrier or other devices. In order to activate this signal connect the re-open input (21) with the +12 V (23). Use voltage free contacts. The reopening signal has priority over the closing signal.
- 22.- **Barrier failure**
This input is used to detect a failure from the Photoelectric Barrier installed.
- 23.- **Out +12 V**
Isolated 12 Volts output available to activate the priority inputs via a voltage free contact.
Features are:
a) **This supply must only be used for this purpose.**
b) This contact must be isolated from any other power supply.
- 24.- **Bypass contact**
This signal is used to connect an external security switch to detect door closed position.
- 25.- **Slow Close**
This signal is used for ordering the door to close slowly. The slow close signal has priority over the control signals and the barrier. It is designed to operate with fire fighting systems.
- 26.- **Floor Level**
This input is used to connect the external emergency supplier to power an opening cycle in the event a power failure when the lift is at a floor level. The Fermator emergency supplier uses a 12V battery, and it is able to provide power for 30 seconds to enable passenger evacuation.

4.5 Output relays and led indicators (from 30 to 47)

Output relays have been provided to give continuous information to the main lift controller concerning the status of the doors.

- **Open**
LED indicator and relay activated when the doors are fully open.
- **Closed**
LED indicator and relay activated when the doors are fully closed and locked.
- **Re-open**
LED indicator and relay activated when the reopening input is operated.
- **Obstruction**
LED indicator and relay activated when an obstacle is detected that stops the doors from closing. The signal will reset when the doors reach the opened or closed position.
- **Barrier Failure**
LED indicator and relay activated when a failure occurs on the Photoelectric Barrier .
- **Over Temperature**
LED indicator and relay activated when the VF7+ Relay temperature or motor temperature exceeds the safety limit. When this output is activated the controller must give the order to the cabin to go to the next floor, open the door to let out the passengers and stop applying voltage to the motor.
- **OK Status**
Blinking green LED indicating proper working conditions. If an alarm occurs the LED illuminates red.

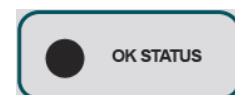
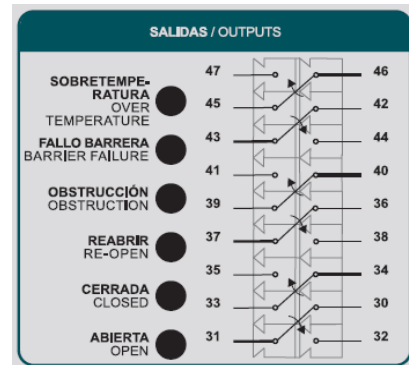

INSTRUCTIONS

DOC-FE.IE.IN.Draft.EN

VF7+ Relay Electronic Module

Version: 0.3

4.6 Autoadjustment push-button (51)

The Autoadjustment push-button is used to set up the doors.

Carries out a Door Learning process to set up the door.

If the Motor calibration has not been completed before, it will be carried out during this process.

This process must be Carries out without the landing door coupled.

The door will carry out a close movement and then will carry out two complete movements to detect the clear opening. From the information obtained the microprocessor will calculate the acceleration and deceleration ramps to give the optimum control of the doors. Once the learning process has been completed the parameters are stored in non-volatile EEPROM.

Learning process:

1. The door will close completely in slow speed until the end to detect the 0 position.
If the first movement is not "close" and the "Bypass Connected to circuit" is connected and "Change rotation by Bypass" activated the VF7+ Relay will arrive at open position, and will automatically change the rotation sense. Then it will start to close.
2. The door will open slowly counting the pulses from the encoder until it reaches the open mechanical stop. "When it starts to open, it is necessary to open the CDL with by hand"
3. The door will close after a short delay. It will calculate the acceleration and deceleration ramps to give the optimum control of the doors.

Note: If the last movement is not "close" without "Bypass Connected to circuit" it is necessary to change the rotation sense and restart the Door Learning process.

4.7 Encoder (55)

An integral quadrature pulse encoder is connected to this input. The purpose of the encoder, which is situated inside the motor, is to inform the control of the exact position and speed of doors.

The software V7.01.08-01 is not compatible with the Fermator asynchronous motor.

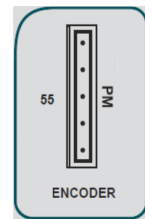

4.8 Motor (56, 57, 58, 59)

Output to the 3 phase motor varying the voltage and frequency to control speed and torque.



VF7+ Relay power supply switch has to be turned off before disconnecting the motor power connector.

Note: Never change the motor with the circuit in power on.

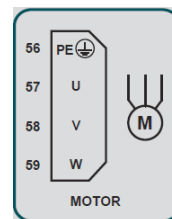

4.9 On / Off Switch

Disconnects the unit from the 230 V AC mains supply.

5 Graphic Interface



Three main objectives can be achieved with the VF7+ Relay graphic interface:

1. **To detect** possible alarms or errors in the unit (Menu Alarms).
2. **To see** the parameters value and active signals (Menu Monitor).
3. **To modify** the internal program parameters and options (Menu Program).
4. **To modify** the configuration of the VF7+ Relay (Menu Configuration).

Once the unit is connected it will show the software version Fermator V7.01.08-01

Push the  button to access the VF7+ Relay menus.

There are four main menus with different submenus: **Menu Alarm**, **Menu Monitor**, **Menu Program**, **Menu Configuration**.

Push the  or  button to select the menu.

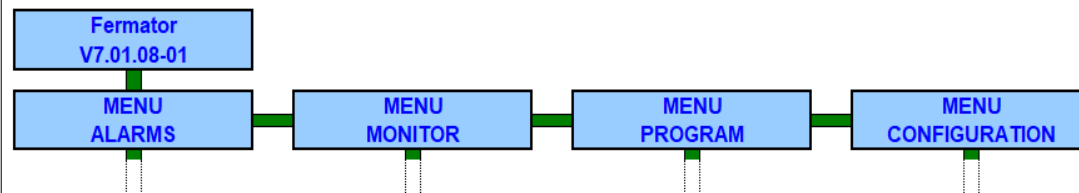



Push the  button to enter the VF7+ Relay menus.

Push the  button to return to the software version screen.

5.1 Menu Alarm

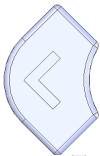
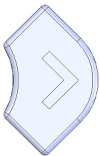
The Menu Alarm shows the alarms activated in the unit.

Push the  or  button to select the submenu.

Push the  button to return to the VF7+ Relay menus.

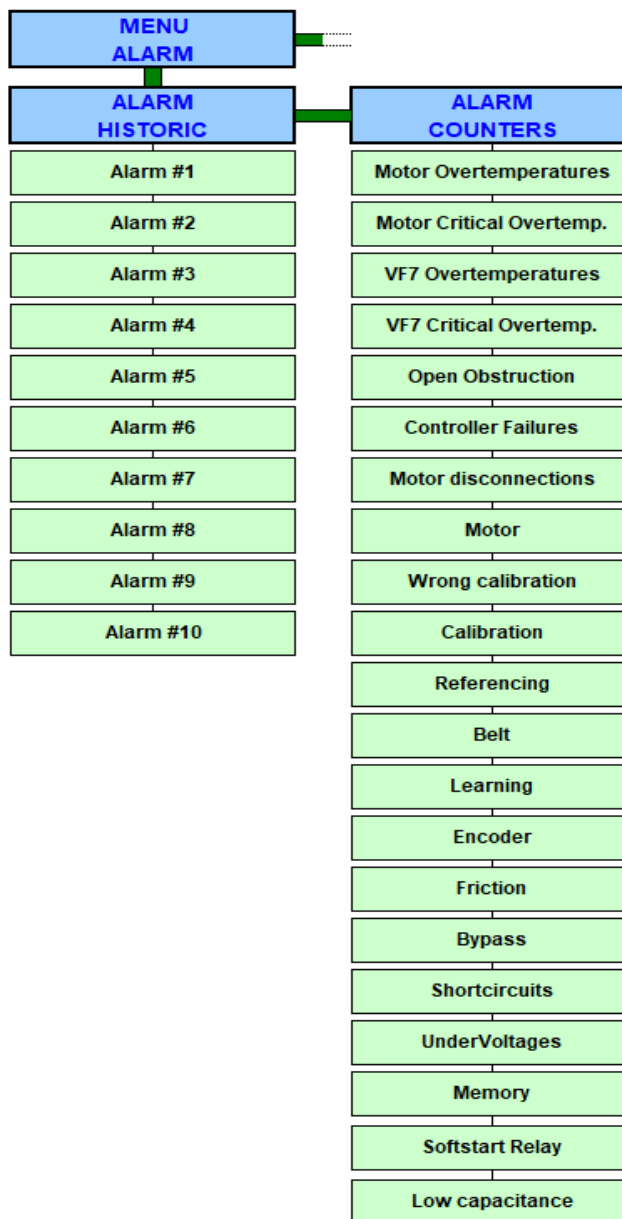

INSTRUCTIONS
DOC-FE.IE.IN.Draft.EN
VF7+ Relay Electronic Module
Version: 0.3

The **Alarms Historic** shows the last ten alarms activated in the unit.

Push the  or  button to see the different alarms.

The VF7+ Relay graphic interface shows the active alarm while the alarm is active.
When the alarm is disabled the VF7+ Relay returns to the last screen before the alarm appearance.

Alarm Counters		
Parameter	Description	Units
Motor Over temperature	Number of times that the Motor over temperature alarm has been activated.	-
Motor Crit. Over temp.	Number of times that the Motor critical over temperature alarm has been activated.	-
VF7 Over temperature	Number of times that the VF7+ Relay over temperature alarm has been activated.	-
VF7 Crit. Over temp.	Number of times that the VF7+ Relay critical over temperature alarm has been activated.	-
Open Obstruction	Number of obstructions in the opening movement.	-
Controller Failures	Number of times that the Controller Failures has been activated.	-
Motor disconnections	Number of times that the motor has been disconnected.	-
Motor	Number of times that the motor alarm has been activated.	-
Wrong calibration	Number of times that the Wrong calibration alarm has been activated.	-
Calibration	Number of times that the Calibration alarm has been activated.	-
Referencing	Number of times that the Referencing alarm has been activated.	-
Belt	Number of times that the Belt alarm has been activated.	-
Learning	Number of times that the Learning alarm has been activated.	-
Encoder	Number of times that the Encoder alarm has been activated.	-
Friction	Number of times that the Friction alarm has been activated.	-
Bypass	Number of times that the Bypass alarm has been activated.	-
Shortcircuits	Number of times that the short-Circuit alarm has been activated.	-
UnderVoltages	Number of times that the UnderVoltage alarm has been activated.	-
Memory	Number of times that the Memory alarm has been activated.	-
Softstart Relay	Number of times that the Softstart Relay alarm has been activated.	-
Low capacitance	Number of times that the Low capacitance alarm has been activated.	-

INSTRUCTIONS

DOC-FE.IE.IN.Draft.EN

VF7+ Relay Electronic Module

Version: 0.3

Description Alarms				
Alarm	Description	Possible problem	Actions	VF7+ Relay recovery
Motor Over temp.	The motor coil has reached 125°C. The VF7+ Relay remains in normal operation.	The door could have high friction. The door could be blocked during the opening/closing movement. The motor could be damaged.	Check the mechanical part. Check the motor.	The alarm is disabled when the motor reaches 105°C or after 3 minutes without measurements.
Motor Critical Over temp.	The motor coil has reached 140°C. The VF7+ Relay stops the normal operation.	The door could have high friction. The door could be blocked during the opening/closing movement. The motor could be damaged.	Check the mechanical part. Check the motor.	The alarm is disabled after 5 minutes.
VF7 Over temp.	The VF7+ Relay has reached 90°C. The VF7+ Relay remains in normal operation.	The door could have high friction. The VF7+ Relay metal cover may not be making good contact.	Check the mechanical part. Tighten the screws of the metal cover. Check that the VF7+ Relay is installed on a metal surface.	The alarm is disabled when the VF7+ Relay reach 70°C.
VF7 Critical Over temp.	The VF7+ Relay has reached 105°C. The VF7+ Relay stops the normal operation.	The door could have high friction. The VF7+ Relay metal cover could not be making good contact.	Check the mechanical part. Tighten the screws of the metal cover. Check that the VF7+ Relay is installed on a metal surface.	The alarm is disabled when the VF7+ Relay reach 70°C.
Open Obstruction	A blockage has been detected during the opening movement in normal operation or in referencing mode and bypass remain activated.	The mechanical part may not be correctly installed. The Bypass contact could be damaged.	Check the mechanical part. Check the Bypass contact.	Push the OK button. The alarm is disabled after 10 seconds.
Controller Failures	An obstruction has been performed in salve mode and the lift controller does not reopened.	The lift controller could has some problems.	Check the lift controller. Check the signal wires.	Push the OK button. The alarm is disabled after 15 seconds.
Motor Disconnect	The unit does not receive a signal from the Motor. If the Motor protection disconnected has been activated.	The motor is disconnected.	The motor must be connected	Push the OK button.
Motor	The unit does not receive a correct signal from the Motor.	The Motor wire could be damaged. The Motor could be damaged. The mechanical part could not be correctly installed.	Check the motor wire. Check the motor. Check the mechanical part.	Push the OK button. The alarm is disabled after 20 seconds.
Wrong Calibration.	When power on, the encoder was not detected correctly by the circuit	The motor or the circuit has been changed, and a new calibration has not been yet completed.	Carry out a calibration.	Push the OK button.
Calibration.	The VF7+ Relay can not complete the Motor Calibration process.	The motor encoder signals are not arriving correctly to the VF7+ Relay.	Check the encoder wire. Carry out a calibration.	Push the OK button.
Referencing	The VF7+ Relay can not recognize the clear opening. The VF7+ Relay remains in normal operation.	The learning process has not been carried out.	Carry out a learning process.	Push the OK button.
Belt	The belt is broken.	The belt could be damaged. The pulley could be damaged.	Check the mechanical part.	Push the OK button.
Learning	The VF7+ Relay can not complete the learning process.	The mechanical part may not be correctly installed.	Carry out a learning process.	Push the OK button.
Encoder	The unit does not receive a signal from the encoder.	The encoder wire could be damaged. The encoder could be damaged.	Check the encoder wire. Check the motor.	Push the OK button.
Friction	The door has high friction. The VF7+ Relay remains in normal operation.	The mechanical part may not be correctly installed.	Check the mechanical part.	Push the OK button.
Bypass	The bypass contact remained closed but the door is open or the bypass contact remained in open but the door is closed. The VF7+ Relay remains in normal operation.	The bypass contact could have short-circuit or be disconnected.	Check the bypass contact.	Complete cycle to close and open with contact connect, carry out a learning process, or change the parameter of bypass contact connect to circuit.

INSTRUCTIONS

DOC-FE.IE.IN.Draft.EN

VF7+ Relay Electronic Module

Version: 0.3

Shortcircuit	The power module has been short-circuited. If 3 short-circuits take place in one minute the alarm will be permanent activated.	The motor could be short-circuited. VF7+ Relay malfunction.	Check the motor wire. Check the motor.	Push the OK button. The alarm is disabled after 10 seconds.
UnderVoltage	The internal voltage decreases under 13V	The VF7+ Relay could have some internal problems.	Disconnect all inputs and outputs	The internal voltage reached 15V
Memory	The memory is failing.	The VF7+ Relay could have some internal problems.	Return to Factory settings.	Return to factory settings.
Softstart Relay	Failure to switch the soft-start relay. The VF7+ Relay remains in normal operation.	The VF7+ Relay could have some internal problems.	Contact Fermator aftersales.	Push the OK button.
Low capacitance	The capacitors voltage ripple is high, indicating a capacity reduction value. The VF7+ Relay remains in normal operation.	The VF7+ Relay could have some internal problems in the capacitors.	Check the CDL spring and contact Fermator aftersales.	Push the OK button.

Remark: If the incidence is not solved with the previous tips please contact Fermator aftersales.

5.2 Menu Monitor

The Menu Monitor displays the VF7+ Relay parameters in real time.

Push the or button to select the submenu.

Push the button to return to the VF7+ Relay menus.

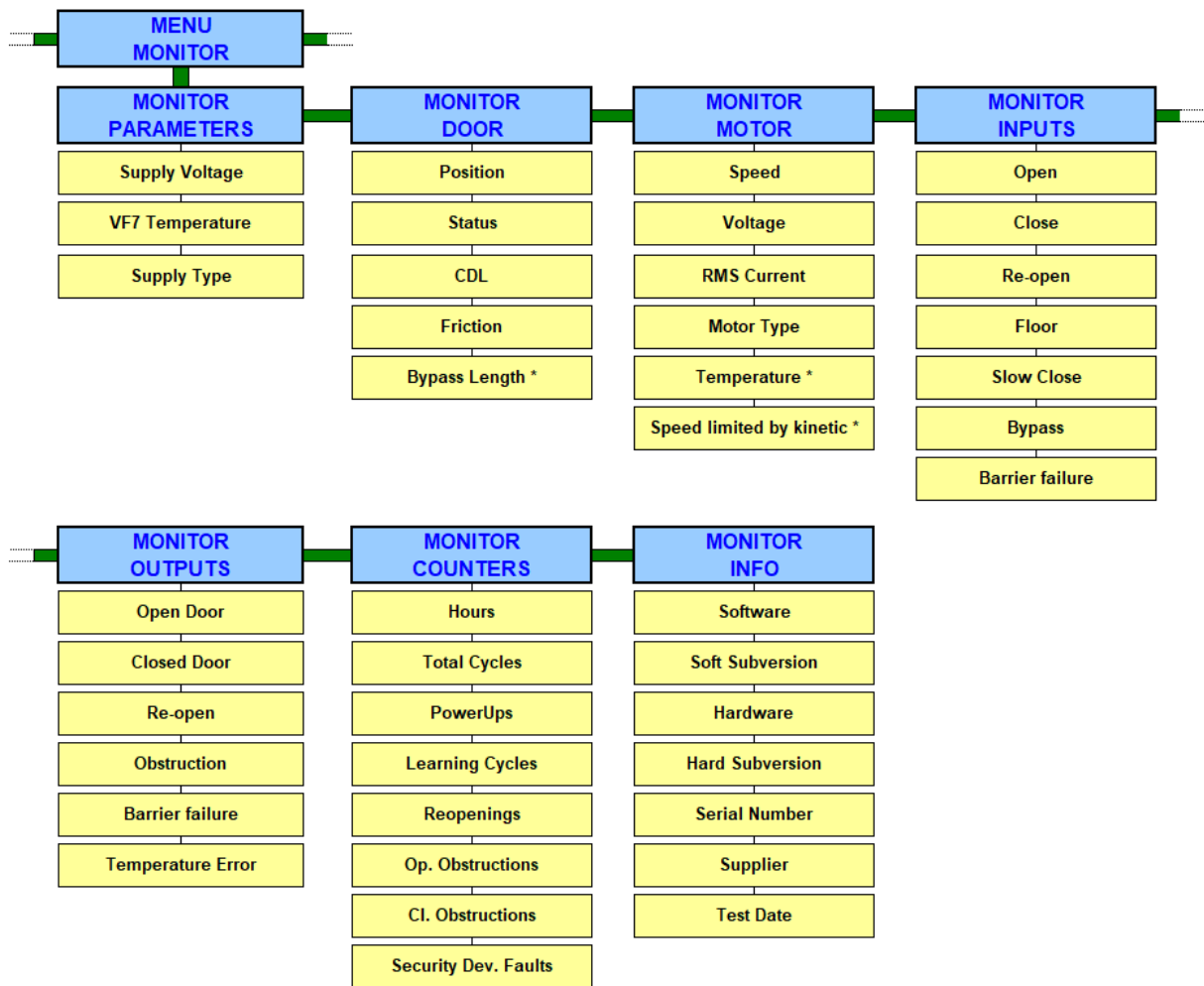

* These parameters can be hidden depending on what options are disabled.

Push the or button to see the different parameters.

Monitor Parameters		
Parameter	Description	Units
Supply Voltage	Voltage supply in AC (V).	V (RMS)
VF7+ Relay Temperature	Temperature in the power module area (°C).	°C
Supply Type	AC or DC supply	-

INSTRUCTIONS

DOC-FE.IE.IN.Draft.EN

VF7+ Relay Electronic Module

Version: 0.3

Monitor Door		
Parameter	Description	Units
Position	Position of the door in m, indicating the zero point with the door closed and the clear opening + Clutch length with the door open.	m
Status	Status of the door (Door closed, Door open, Closing door, ...)	-
CDL	Door with Car Door Lock (automatic detection during learning).	-
Friction	Friction value detected during the learning process. Frictionless door when this parameter is 0.	Scaled from 0 to 150
Bypass Length *	The distance from the closed door position to open bypass contact detected during the learning process. * This parameter is hidden if the option "Bypass Connected to circuit" is disconnected.	m

Monitor Motor		
Parameter	Description	Units
Speed	Motor speed.	m/s
Voltage	Voltage that the circuit applies to the motor (V).	V (RMS)
RMS Current	Output current (A).	A
Motor Type	Motor connected to the circuit.	-
Temperature *	Temperature in the PM motor (Temperature measurement option has to be enabled). * This parameter is hidden if the option "Temp. Measurement" is disable.	°C
Speed limited by kinetic energy *	This is the maxim speed in closing limited by the kinetic energy. * This parameter is hidden if the option "Energy limit" is disable.	m/s

Monitor Inputs		
Parameter	Description	Units
Open	Status of the open signal.	-
Close	Status of the close signal.	-
Re-open	Status of the re-open signal.	-
Floor	Status of the floor level signal.	-
Slow Close	Status of the slow close signal.	-
Bypass	Status of the Close Position signal.	-
Barrier failure	Status of the Barrier failure.	-

Monitor Outputs		
Parameter	Description	Units
Open Door	Status of the door open signal.	-
Closed Door	Status of the door closed signal.	-
Re-open	Status of the Re-open signal.	-
Obstruction	Status of the obstruction signal.	-
Barrier failure	Status of the Barrier failure signal.	-
Temperature Error	Status of the temperature signal.	-

INSTRUCTIONS
DOC-FE.IE.IN.Draft.EN
VF7+ Relay Electronic Module
Version: 0.3

Monitor Counters		
Parameter	Description	Units
Hours	Number of working hours.	-
Total Cycles	Number of cycles completed by the door.	-
Powerups	Number of connections to the mains supply or blackouts suffered.	-
Learning Cycles	Number of learning cycles made.	-
Reopenings	Number of re-open cycles. Only by external signal inputs of reopening.	-
Op. Obstructions	Number of obstructions in the opening movement.	-
Cl. Obstructions	Number of blockages in the closing movement.	-
Security Device Faults	Number of times the light curtain blocked more than 2 minutes or Barrier failure activates	-



Monitor Information		
Parameter	Description	Units
Software Version	Circuit software version.	-
Software subversion	Circuit software subversion.	-
Hardware Version	Circuit hardware version.	-
Hardware Subversion	Circuit hardware subversion.	-
Serial Number	Identification serial number for each unit.	-
Supplier	Supplier identification code.	-
Test Date	Date of manufacture.	-

5.3 Menu Program



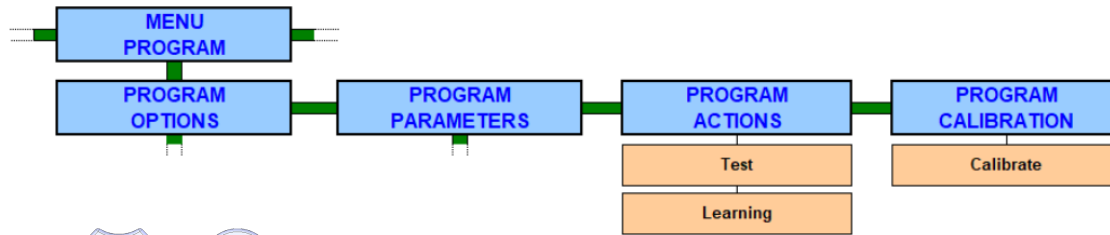

The Menu Program displays the VF7+ Relay internal parameters and options.

Push the  or  button to select the sub-menu.



Push the  or  button to see the different parameters of each submenu.

To modify a parameter or an option carry out the following steps:

1. Select the parameter/option to be modified and push the  button to enter in modify mode.
2. The parameter value or option status will appear blinking; push the  or  button to increase/decrease the parameter value or enable/disable the option.
3. Push the  button to save the modification.

5.3.1 Program Options

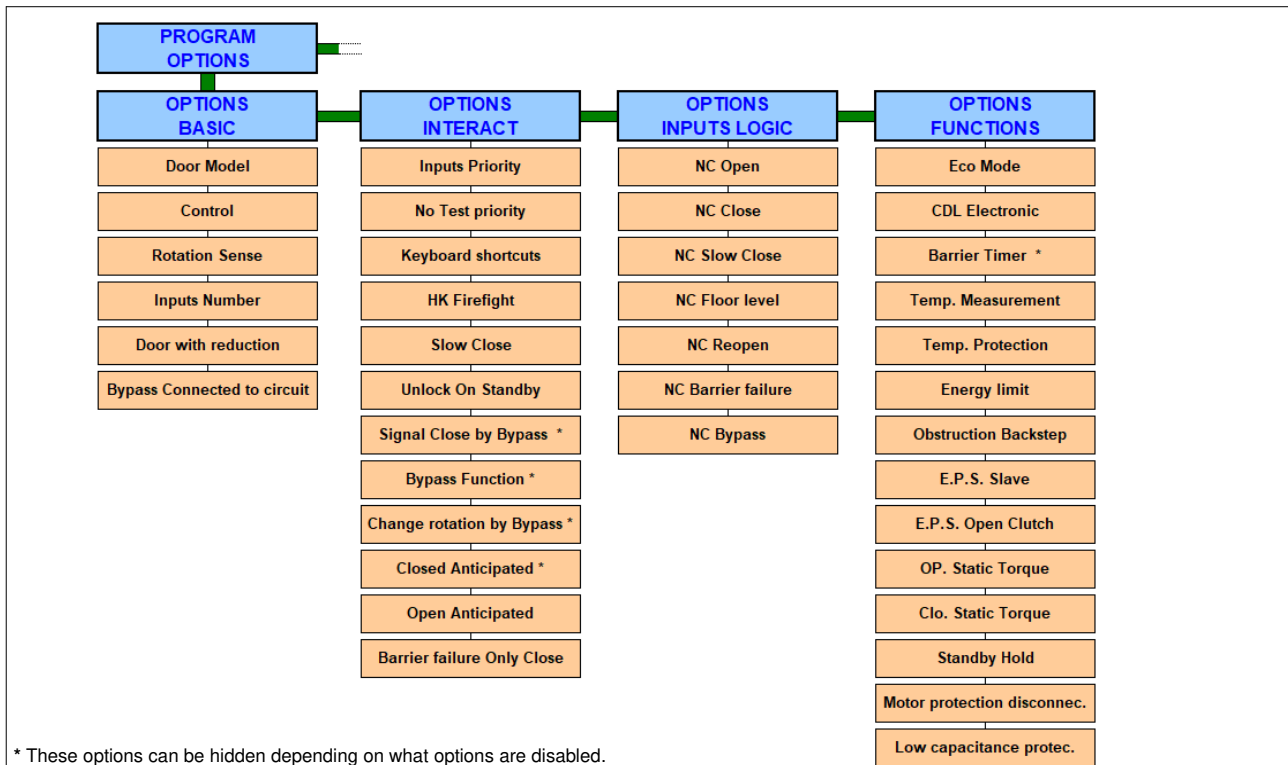







* These options can be hidden depending on what options are disabled.

INSTRUCTIONS
DOC-FE.IE.IN.Draft.EN
VF7+ Relay Electronic Module
Version: 0.3

Program Options		
Options basic		
Door Model	T1	Automatic horizontal sliding door 1 panel side opening.
	T2	Automatic horizontal sliding door 2 panel side opening.
	T3	Automatic horizontal sliding door 3 panel side opening.
	T4	Automatic horizontal sliding door 4 panel side opening.
	C2	Automatic horizontal sliding door 2 panel centre opening.
	C4	Automatic horizontal sliding door 4 panel centre opening.
	C6	Automatic horizontal sliding door 6 panel centre opening.
	C8	Automatic horizontal sliding door 8 panel centre opening.
Control	Master	The unit will execute the instructions directly. Example: Curtain activation will cause the doors to re-open immediately without any signal from the lift controller.
	Slave	There is no automatic reopen movements. The doors will only react to an instruction given by the main lift controller. Example: When the light curtain detects an obstacle instead of reopen automatically the VF7+ Relay module will send a signal to the lift controller with the Light Curtain output (42, 43, 44). The main lift controller must remove the close signal and active the open signal.
Rotation Sense	Clockwise (CW)	During the opening movement the motor will rotate clockwise.
	Counterclockwise (CCW)	During the opening movement the motor will rotate counterclockwise.
Inputs Number	1 Input	<p>The unit will be controlled by a single input. Any voltage between 12 V DC to 60 V DC or 60 V AC to 125 V AC applied between terminals 8 & 10 will close the doors. Without an active input the door remains open. The open input is not used.</p> <div style="border: 1px solid black; padding: 5px; margin: 10px 0;"> <p>1 INPUT:</p> <p>Voltage 0 V. OPEN</p> <p>Voltage 12...60 V DC, 60...125 V AC. CLOSE</p> </div>
	2 Inputs	<p>The unit will be controlled by two independent inputs. Any voltage between 12 V DC to 60 V DC or 60 V AC to 125 V AC applied between terminals 8 & 10 will cause the doors to close. And between terminals 10 & 12 will cause the doors to open. In the absence of a signal the doors will remain static. If both inputs are applied then the open signal has priority.</p> <div style="border: 1px solid black; padding: 5px; margin: 10px 0;"> <p>2 INPUTS:</p> <p>Voltage 12...60 V DC, 60...125 V AC. OPEN</p> <p>Voltage 12...60 V DC, 60...125 V AC. CLOSE</p> </div>
Door with reduction	This option allow select if the operator has reduction or not. If "No" reduction is selected, the Gear Ratio and Pinion Perimeter parameters in Program Parameters menu will be hidden. These parameters will automatically be set to 80mm for the Pinion Perimeter and 1.00 for the Gear Ratio.	
Bypass Connected to circuit	This option is to inform the circuit that the closed door contact is connected to the circuit. In the event that it is connected to the circuit, it enables the options referring to the Bypass, otherwise these options are hidden.	

INSTRUCTIONS
DOC-FE.IE.IN.Draft.EN
VF7+ Relay Electronic Module
Version: 0.3

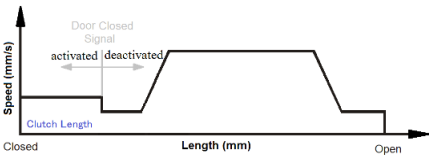
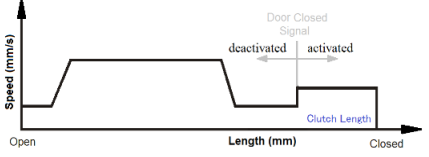
Program Options		
Options interact		
Inputs Priority	Open	In the event that the open signal and close signals are activated at the same time the door must open.
	Close	In the event that the open signal and close signals are activated at the same time the door must close.
	Stop	In the event that the open signal and close signals are activated at the same time the door must stop.
	Slow Close	In the event that the open signal and close signals are activated at the same time the door must close in slow speed.
No Test priority	If enabled, the Test cycle does not have priority over the input signals.	
Keyboard shortcuts	<p>If enabled, keyboard shortcuts are allowed in:</p> <ul style="list-style-type: none"> - The home screen: <ul style="list-style-type: none"> • Learning: Push the  button during 3 seconds. • Test: Push the  button during 3 seconds. • Rotates the screen display: Push the  and  button during 1 seconds. • Move the door to open: Push  button during 1 seconds. • Move the door to close: Push  button during 1 seconds. - The Menu Alarms: <ul style="list-style-type: none"> • Reset Historic Alarms: Push the  button during 3 seconds. 	
HK Firefight	If enabled, the first opening operation after a power up it is totally "slave".	
Slow close signal	Action	Slow close is performed when the Slow close input is activated.
	Command	Slow close/open is performed when the Slow close input and Close/Open inputs are activated.
Unlock on standby	If enabled, with the clutch/CDL fully closed the VF7+ Relay opens the clutch/CDL only if the closing signal is removed or after a delay time (Eco Delay). Once the clutch is open the VF7+ Relay remains in standby. (This option is not compatible with Eco Mode No).	
Signal Clo. by Bypass *	<p>When it is active the closed signal output takes the value of the bypass input.</p> <p>IMPORTANT: With this option enabled it is possible to have a output signal open and close active at the same time.</p> <p>* This option is hidden if the option "Bypass Connected to circuit" is disconnected.</p>	
Bypass Function *	<p>When it is active after a power blackout the VF7+ Relay will only need to reach the closed door position once (detection of Bypass contact transition closed to open) to apply the normal speed profile.</p> <p>IMPORTANT: The bypass contact must be installed before carrying out the door learning process. If the bypass contact is removed or changes its position a door learning process has to be repeated.</p> <p>* This option is hidden if the option "Bypass Connected to circuit" is disconnected.</p>	
Change rotation by Bypass *	<p>When it is active the option "Rotation Sense" is auto detected during the learning process.</p> <p>* This option is hidden if the option "Bypass Connected to circuit" is disconnected.</p>	
Close Anticipated *	<p>The Closed output is activated when the door is closed but does not need the Clutch to close. This signal is activated when the door arrives to the distance of the "Clutch Length".</p> <div style="display: flex; justify-content: space-around;"> <div style="text-align: center;">  <p>Opening</p> </div> <div style="text-align: center;">  <p>Closing</p> </div> </div> <p>* This option is hidden if the option "Bypass Connected to circuit" is connected and "Signal Close by Bypass" is activated .</p>	
Open Anticipated	The Open output is activated when the door is within 50 mm of fully open.	
Barrier fail. Only Close	When it is active the Barrier failure output will only be activated when the door is closing.	

INSTRUCTIONS
DOC-FE.IE.IN.Draft.EN
VF7+ Relay Electronic Module
Version: 0.3

Program Options	
Options inputs logics	
NC Open	If enabled, Open signal is activated without voltage (Normally closed contact).
NC Close	If enabled, Close signal is activated without voltage (Normally closed contact).
NC Slow Close	If enabled, Slow close signal is activated without voltage (Normally closed contact).
NC Floor level	If enabled, Floor level is activated without voltage (Normally closed contact).
NC Reopen	If enabled, Reopen signal is activated without voltage (Normally closed contact).
NC Barrier failure	If enabled, Barrier failure is activated without voltage (Normally closed contact).
NC Bypass	If enabled, Close position is activated without voltage (Normally closed contact).

Program Options		
Options functions		
Eco Mode	No	The VF7+ Relay always applies the Close Maintenance Torque.
	Control *	The VF7+ Relay stops applying the Close Maintenance Torque if the closing signal is removed. * Only selectable with option basic "Inputs Number" in two inputs
	Control delay *	The VF7+ Relay stops applying the Close Maintenance Torque if the closing signal is removed and the programmable time delay has finished (Eco delay). * Only selectable with option basic "Inputs Number" in two inputs
	Close delay *	The VF7+ Relay stops applying the Close Maintenance Torque after a programmable time delay (Eco delay) since the door is closed. * Only selectable with option basic "Inputs Number" in one inputs and Unlock on standby activated.
CDL Electronic	If enabled, after a power failure the VF7+ Relay opens the Car Door Lock if the cabin is at floor level.	
Barrier timer *	If enabled, an intelligent timer is used in case of a barrier permanent obstruction. The protection is disabled after 2 minutes permanently blocked. If a physical obstruction occurs during the next closing movement, the VF7+ Relay reopens and wait 2 minutes before closing again. If another physical obstruction occurs during the next closing cycle the VF7+ Relay reopens and wait 4 minutes before closing again. Finally, if another physical obstruction occurs during the next closing cycle the VF7+ Relay reopens and remains open. The photocell or curtain is enabled again when there is not any physical obstruction during the closing movement. * This option is hidden if the option "Security Device" is None.	
Temperature measurement	If enabled, the VF7+ Relay measures the motor temperature.	
Temperature Protection	Drive	When the overheating alarm is active the circuit does not allow the door closing cycle.
	Lift	When the overheating alarm is active the lift does not allow the door closing cycle.
Energy limit	The circuit limits the maximum velocity in order not to exceed a kinetic energy of 10 joules.	
Obstruction Backstep	If enabled and an obstruction occurs in the opening or closing movement the VF7+ Relay makes a backward movement and waits a delay time (Backstep delay).	
E.P.S. Slave	If enabled, the Emergency Power Supplier will not open the door if the closing signal is activated.	
E.P.S. Open Clutch	If enabled, the Emergency Power Supplier will only open the car door clutch.	
Op. Static Torque	If enabled, a constant torque will be applied when the door is completely open.	
Clo. Static Torque	If enabled, a constant torque will be applied when the door is completely closed. Closing constant torque will be applied according to the Eco Mode selected option.	
Standby Hold	If enabled, The circuit maintains the door stopped in any position of the clear opening. In this case the parameters "Hold torque" and "Standby Hold Time" are enabled otherwise these parameters are hidden.	
Motor protection disconnec.	If enabled, The circuit checks if the motor is connected. In the event the motor is disconnected the circuit has an alarm.	
Low capacitance protec.	If enabled, The circuit checks the capacitors voltage ripple. In the event the capacitors voltage ripple is high the circuit has an alarm.	

5.3.2 Program Parameters

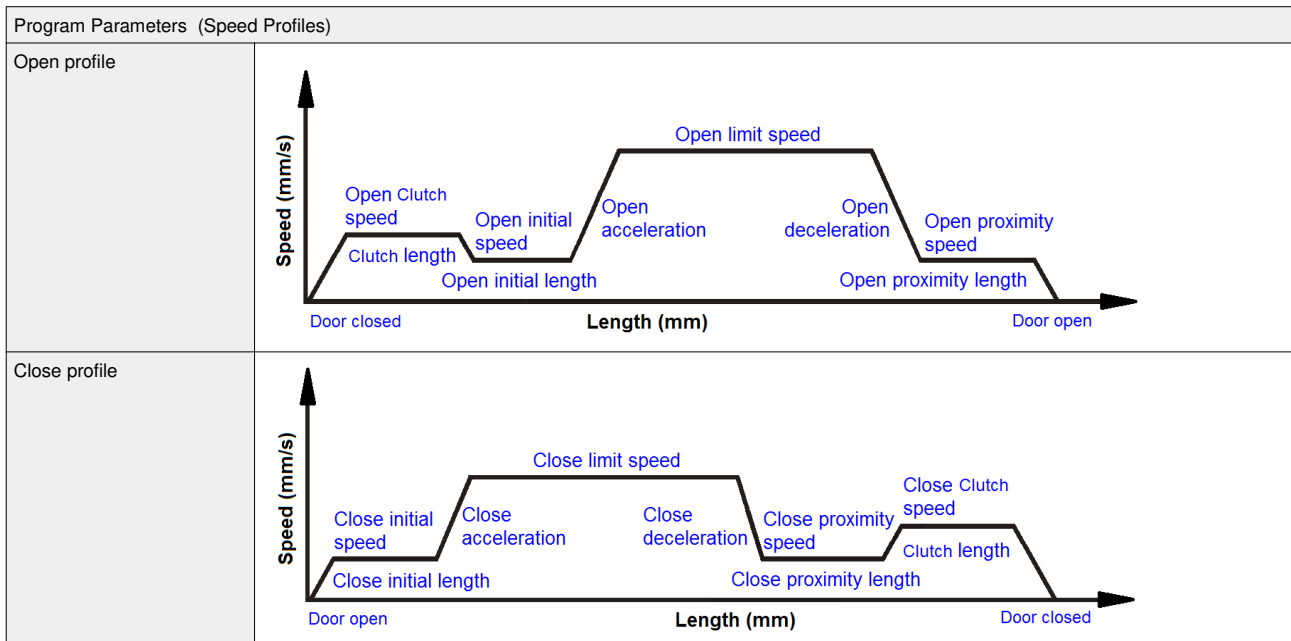
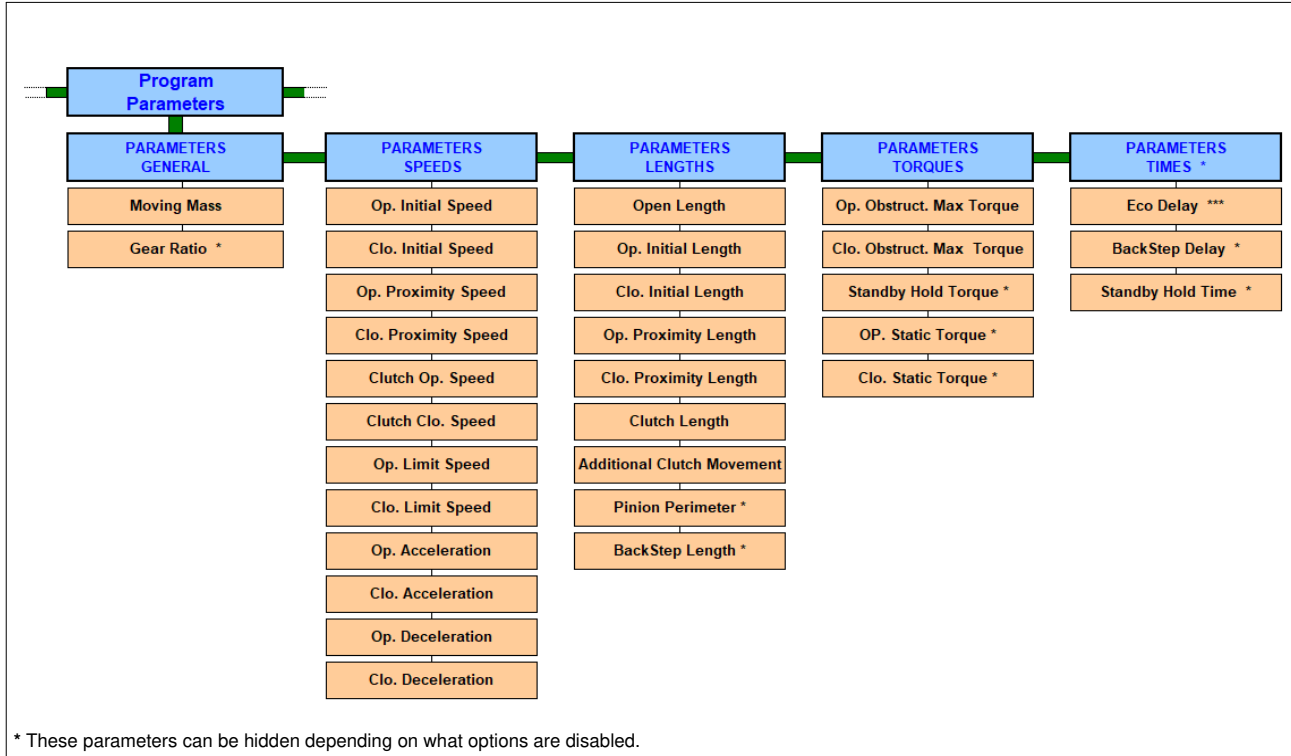

INSTRUCTIONS
DOC-FE.IE.IN.Draft.EN
VF7+ Relay Electronic Module
Version: 0.3

Program Parameters				
Parameters generals				
Parameter	Description	Units	Min	Max
Moving mass	Moving mass of the door	(kg)	1	500
Gear ratio	Gear ratio when a reduction pulley is used.	-	1.00	10.00

Program Parameters				
Parameters speeds				
Parameter	Description	Units	Min	Max
Open Initial Speed	The initial speed at opening.	(m/s)	0.025	0.100
Close Initial Speed	The initial speed at closing.	(m/s)	0.025	0.100
Open Proximity Speed	The approximation speed at opening.	(m/s)	0.025	0.100
Close Proximity Speed	The approximation speed at closing.	(m/s)	0.025	0.100
Open Clutch Speed	Clutch speed at opening.	(m/s)	0.025	0.100
Close Clutch Speed	Clutch speed at closing.	(m/s)	0.025	0.100
Open Limit Speed	Speed limit at opening.	(m/s)	0.100	1.000
Close Limit Speed	Speed limit at closing.	(m/s)	0.100	0.600
Open Acceleration	The opening acceleration.	(m/s ²)	0.050	0.700
Close Acceleration	The closing acceleration.	(m/s ²)	0.050	0.700
Open Deceleration	The opening deceleration.	(m/s ²)	0.050	0.700
Close Deceleration	The closing deceleration.	(m/s ²)	0.050	0.500

Program Parameters				
Parameters lengths				
Parameter	Description	Units	Min	Max
Open Length	Door clear opening + Clutch length.	(m)	0.100	5.000
Open Initial Length	The space at the initial opening movement.	(m)	0.000	0.100
Close Initial Length	The space at the initial closing movement.	(m)	0.001	0.100
Open Proximity Length	The space at the final opening movement.	(m)	0.001	0.050
Close Proximity Length	The space at the final closing movement.	(m)	0.001	0.040
Clutch Length	The required space to open/close the Clutch. In the event that the operator has not a Clutch (semi-automatic) put this value to 0.	(m)	0.000	0.100
Additional Clutch Movement	Additional clutch movement to personalize the opening distance in emergency mode.	(m)	0.000	0.200
Pinion Perimeter	Perimeter of the motor pinion.	(mm)	10.00	300.00
Backstep length *	Length of the backwards movement (Obstruction Backstep option). * This parameter is hidden if the option "Obstruction Backstep" is disabled.	(m)	0.010	0.150

Program Parameters				
Parameters torques				
Parameter	Description	Units	Min	Max
Open Obstruction Max	Maximum torque in the opening movement. (value 0 is disabled the limit torque)	(N·m)	1.0	4.0
Close Obstruction Max	Maximum torque in the closing movement. (value 0 is disabled the limit torque)	(N·m)	0.5	3.0
Hold torque*	Torque applied to maintain the door stopped in any position of the clear opening. * This parameter is hidden if the option "Standby Hold" is disabled.	(N·m)	0.5	1.5
Op. Final Constant Torque *	Static torque applied to maintain the door stopped in open positions. * This parameter is hidden if the option "Op. Static Torque" is disabled.	(N·m)	0.1	1.1
Clo. Final Constant Torque *	Static torque applied to maintain the door stopped in closed positions. * This parameter is hidden if the option "Clo. Static Torque" is disabled.	(N·m)	0.1	1.1

INSTRUCTIONS
DOC-FE.IE.IN.Draft.EN
VF7+ Relay Electronic Module
Version: 0.3

Program Parameters				
Parameters times *				
* This menu is hidden if the option "ECO mode" is "No" or "Control" and the options "Obstruction Backstep" and "Standby Hold " are disabled.				
Parameter	Description	Units	Min	Max
Eco Delay *	Programmable time delay (Eco mode option). * This parameter is hidden if the option "ECO mode" is "No" or "Control"	(s)	1.0	300.0
Backstep delay *	Programmable time delay (Obstruction Backstep option). * This parameter is hidden the option "Obstruction Backstep" is disabled.	(s)	0.0	5.0
Standby Hold Time *	Programmable time during the hold voltage is applied. * This parameter is hidden if the option "Standby Hold " is disabled.	(s)	1.0	1800.0

5.3.3 Program Actions



Program Actions	
Test	Carries out a door open or close cycle to verify proper operation.
Door Learning	<p>Carries out a Door Learning process to set up the door. If the Motor calibration has not been completed before, it will be carried out during this process.</p> <p>This process must be Carries out without the landing door coupled.</p> <p>The door will carry out a close movement and then will carry out two complete movements to detect the clear opening. From the information obtained the microprocessor will calculate the acceleration and deceleration ramps to give the optimum control of the doors. Once the learning process has been completed the parameters are stored in non-volatile EEPROM.</p> <p>Learning process:</p> <ol style="list-style-type: none"> 1. The door will close completely in slow speed until the end to detect the 0 position. If the first movement is not "close" and the "Bypass Connected to circuit" is connected and "Change rotation by Bypass" activated the VF7+ Relay will arrive at open position, and will automatically change the rotation sense. Then it will start to close. 2. The door will open slowly counting the pulses from the encoder until it reaches the open mechanical stop. "When it starts to open, it is necessary to open the CDL with by hand" 3. The door will close after a short delay. It will calculate the acceleration and deceleration ramps to give the optimum control of the doors. <p>Note: If the last movement is not "close" without "Bypass Connected to circuit" it is necessary to change the rotation sense and restart the Door Learning process.</p>

5.3.4 Program Calibration



Program Calibration	
Calibration	<p>The motor calibration process has to be carried out to detect the electrical characteristics of the motor installed.</p> <p>The calibration has to be carried out only once when the motor or the VF7+ Relay module are replaced.</p> <p>Remove the motor belt before carrying out a calibration</p> <p><u>To perform an optimal calibration of the motor installed the process has to be carried out without load. Never perform calibration with the car door and landing door coupled.</u></p>



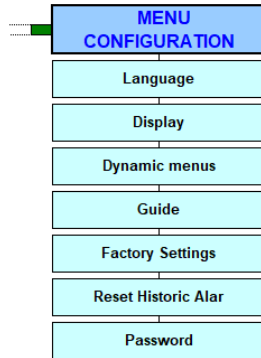

5.4 Menu Configuration

The Menu Configuration is used to change the VF7+ Relay configuration.



Push the  or  button to see the different options.

To modify an option carry out the following steps:

1. Select the option to be modify and push the  button to enter in modify mode.
2. The option status will appear blinking, push the  or  button to enable/disable it.
3. Push the  button to save the modification.

Menu Configuration																																			
Language	The unit can be programmed in the following languages: <ul style="list-style-type: none"> • English • Spanish • German • French • Italian 																																		
Display	Rotates the screen display (Straight/Invert).																																		
Dynamic menus	If disabled, the VF7+ Relay show all menus.																																		
Guide	Starting guide to configure main parameters and options in VF7+ Relay. The following steps have to be followed in order to configure VF7+ Relay according to the Guide: <div style="text-align: right; margin-top: 10px;"> <table border="0"> <tr> <td></td> <td>Default value</td> </tr> <tr> <td></td> <td>↓</td> </tr> <tr> <td>Language</td> <td>⇒⇒⇒ Español</td> </tr> <tr> <td>Door model</td> <td>⇒⇒⇒ T2</td> </tr> <tr> <td>Control</td> <td>⇒⇒⇒ Master</td> </tr> <tr> <td>Rotation sense</td> <td>⇒⇒⇒ CCW</td> </tr> <tr> <td>Inputs</td> <td>⇒⇒⇒ 2</td> </tr> <tr> <td>Moving mass</td> <td>⇒⇒⇒ 60kg</td> </tr> <tr> <td>Clutch length</td> <td>⇒⇒⇒ 0.052</td> </tr> <tr> <td>Bypass connected to circuit</td> <td>⇒⇒⇒ NO</td> </tr> <tr> <td>Door with reduction</td> <td>⇒⇒⇒ NO</td> </tr> <tr> <td>Learning</td> <td>⇒⇒⇒ Run</td> </tr> </table> </div> <div style="margin-top: 10px;"> <table border="0"> <tr> <td>YES</td> <td>NOT</td> </tr> <tr> <td> <table border="0"> <tr> <td>Gear ratio</td> <td>⇒⇒⇒ 1.00</td> </tr> <tr> <td>Pinion perimeter</td> <td>⇒⇒⇒ 80.00</td> </tr> <tr> <td>Learning</td> <td>⇒⇒⇒ Run</td> </tr> </table> </td> <td></td> </tr> </table> </div>		Default value		↓	Language	⇒⇒⇒ Español	Door model	⇒⇒⇒ T2	Control	⇒⇒⇒ Master	Rotation sense	⇒⇒⇒ CCW	Inputs	⇒⇒⇒ 2	Moving mass	⇒⇒⇒ 60kg	Clutch length	⇒⇒⇒ 0.052	Bypass connected to circuit	⇒⇒⇒ NO	Door with reduction	⇒⇒⇒ NO	Learning	⇒⇒⇒ Run	YES	NOT	<table border="0"> <tr> <td>Gear ratio</td> <td>⇒⇒⇒ 1.00</td> </tr> <tr> <td>Pinion perimeter</td> <td>⇒⇒⇒ 80.00</td> </tr> <tr> <td>Learning</td> <td>⇒⇒⇒ Run</td> </tr> </table>	Gear ratio	⇒⇒⇒ 1.00	Pinion perimeter	⇒⇒⇒ 80.00	Learning	⇒⇒⇒ Run	
	Default value																																		
	↓																																		
Language	⇒⇒⇒ Español																																		
Door model	⇒⇒⇒ T2																																		
Control	⇒⇒⇒ Master																																		
Rotation sense	⇒⇒⇒ CCW																																		
Inputs	⇒⇒⇒ 2																																		
Moving mass	⇒⇒⇒ 60kg																																		
Clutch length	⇒⇒⇒ 0.052																																		
Bypass connected to circuit	⇒⇒⇒ NO																																		
Door with reduction	⇒⇒⇒ NO																																		
Learning	⇒⇒⇒ Run																																		
YES	NOT																																		
<table border="0"> <tr> <td>Gear ratio</td> <td>⇒⇒⇒ 1.00</td> </tr> <tr> <td>Pinion perimeter</td> <td>⇒⇒⇒ 80.00</td> </tr> <tr> <td>Learning</td> <td>⇒⇒⇒ Run</td> </tr> </table>	Gear ratio	⇒⇒⇒ 1.00	Pinion perimeter	⇒⇒⇒ 80.00	Learning	⇒⇒⇒ Run																													
Gear ratio	⇒⇒⇒ 1.00																																		
Pinion perimeter	⇒⇒⇒ 80.00																																		
Learning	⇒⇒⇒ Run																																		

INSTRUCTIONS

DOC-FE.IE.IN.Draft.EN

VF7+ Relay Electronic Module

Version: 0.3

	When making the first start-up in a VF7+ Relay replacement the menu will be automatically opened so as to configure the parameters related to the door where the VF7+ Relay will be replaced.
Factory Settings	Sets all parameters to the factory value.
Reset Historic Alarms	Clear the Historic Alarms.
Password	Entering the correct password the advanced menu will be unlocked.



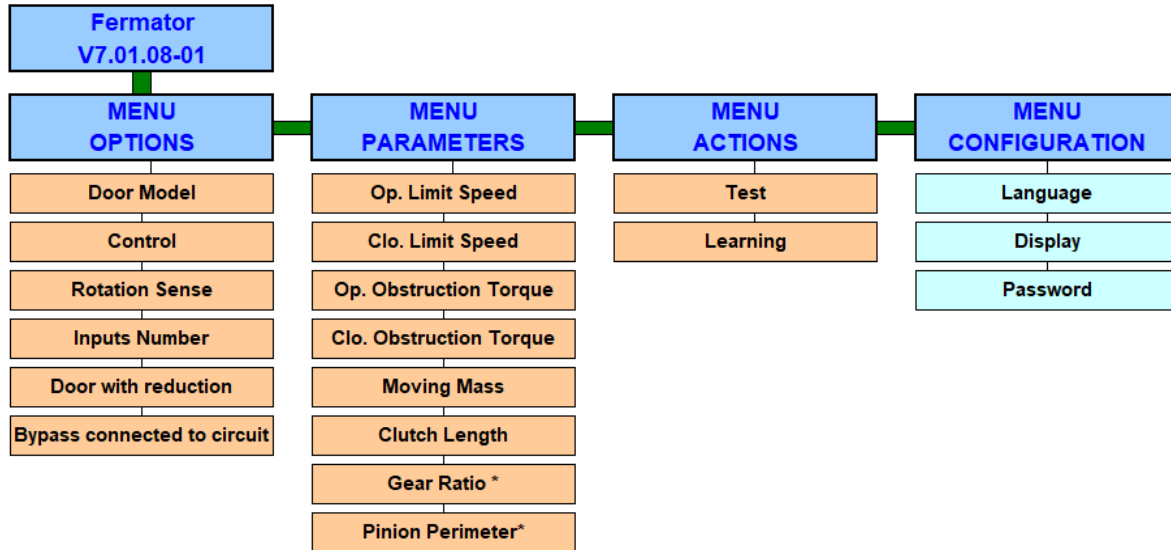

5.5 Standard Reduced Menu

The Standard reduced menu is shown below.



Push the  or  button to see the different options.

To modify an option carry out the following steps:

4. Select the option to be modify and push the  button to enter in modify mode.
5. The option status will appear blinking, push the  or  button to enable/disable it.
6. Push the  button to save the modification.

By default, the devices will be programmed with the reduced menu. To visualize the standard menu, the technical staff must be introduce in the Password option the code ↓↓↓↑↑↑↑ .

The standard menu can be visualized until the screen shutdown.

6 Installation process

The whole installation process has to be carried out when a new circuit board is installed on a door.

1. **Connections**
 - Connect the motor wire and encoder wire (#55, #56, #57, #58, #59).
 - Disconnect all other inputs and outputs.
 - If it has been installed the Bypass to the VF7+ Relay, Connect the bypass wire (#23, #24).
 - Connect the 230 V AC mains supply to the controller (#5, #6, #7).
2. **Switch on the VF7+ Relay door controller** button I/O in the front of the box.
3. **Follow the Guide** for configuration of VF7+ Relay main parameters if the circuit board is a replacement.

INSTRUCTIONS

DOC-FE.IE.IN.Draft.EN

VF7+ Relay Electronic Module

Version: 0.3

Starting guide to configure main parameters and options in VF7+ Relay. The following steps have to be followed in order to configure VF7+ Relay according to the Guide:

- **Language:** select Language.
- **Moving mass:** adjust the mass of the door where the VF7+ Relay has been installed.
- **Door model:** select door opening according to the door where VF7+ Relay has been installed (T1, T2, T3, T4, C2, C4, C6 or C8).
- **Clutch length:** introduce the length of the belt pulling rod.
- **Door with reduction:** select if the operator works with reduction.
 - In the event that the operator has reduction, next parameters will be showed.**
 - **Gear ratio:** introduce the gear ratio when the motor has reduction.
 - **Pinion perimeter:** introduce the pinion perimeter value in mm.
- **Learning:** initiate the learning and calibration process.

IMPORTANT: If the circuit is turn on, and the Auto-adjustment is pressed, after end the learning process, the circuit will start the Guide Menu. Always a Basic configuration will be necessary to ensure the EN81-20 compliance.

4. Door Test.

- Activate the Test option to open the door and verify the proper operation. Activate again the test option to close the door.

5. Connect the wires coming from the lift controller.

- Connect the inputs cables (#8 to #12).
- Connect the priority inputs cables (#21 to #26).
- Connect the relays outputs cables that inform the lift controller (#30 to #47).

If the circuit board is already installed only do this steps

1. Connections

- Connect the motor wire and encoder wire (#55, #56, #57, #58, #59).
- Disconnect all other inputs and outputs.
- If it has been installed the Bypass to the VF7+ Relay, Connect the bypass wire (#23, #24).
- Connect the 230 V AC mains supply to the controller (#5, #6, #7).

2. Switch on the VF7+ Relay door controller button I/O in the front of the box.

3. Place the door in the middle position in order to see the starting movement.

4. Activate the Door Learning option to start the learning cycle. Go to *Menu Program* → *Program Actions* in the VF7+ Relay Graphic Interface. **This process must be done without the landing door coupled.**

The correct steps that the door has to make are:

The door will close completely in slow speed until the end to detect the 0 position.

If the first movement is not "close" and the "Bypass Connected to circuit" is connected and "Change rotation by Bypass" activated the VF7+ Relay will arrive at the open position and it will automatically change the rotation sense. Then it will start to close.

The door will open slowly counting the pulses from the encoder until it reaches the open mechanical stop. "When it starts to open, it is necessary to open the CDL with by hand"

The door will close after a short delay. It will calculate the acceleration and deceleration ramps to give the optimum control of the doors.

Note: If the last movement is not "close" without Bypass Connected to circuit, it is necessary to change the rotation sense and restart the Door Learning process .

5. Door Test.

- Activate the Test option to open the door and verify the proper operation. Activate again the test option to close the door.

6. Connect the wires coming from the lift controller.

- Connect the inputs cables (#8 to #12).
- Connect the priority inputs cables (#21 to #26).
- Connect the relays outputs cables that inform the lift controller (#30 to #47).

7 Power failures

The VF7+ Relay incorporates two new security systems related to power failures:

- **Anti-banging system:** When a power failure occurs while the door is opening, closing or fully open, the new anti-banging system brakes the PM motor to perform a slow closing and avoid the door slamming on closing.
- **CDL electronic:** When a power failure occurs while the door is fully closed, the VF7+ Relay detects the voltage drop and opens the CDL if the car is at floor level. This new security system could be used with a CDL. The CDL electronic system could be enabled or disabled by software.

Note: After the power supply has been restored and the open signal is activated the doors will open slowly for the first operation in order to recognize the clear opening.

8 Lift standard EN 81-20

In this section the modifications are listed for customer awareness in order to comply with the new lift standard EN 81-20.

8.1 Kinetic energy

- The average closing speed has to be limited to 10 J. To create this limit it is necessary to know the moving mass, the door opening and the number of door panels. These parameters are programmed by default except when the unit is a spare part. In this case the parameters have to be introduced by the VF7+ Relay menu program .

In order to comply with the standard it is necessary to configure some options and parameters:

Menu	Option	Configuration to comply with EN81-20
Programming options	Door model	Select door model.
	Curtain timer	Enable
	Eco Mode	Select modes Control, Close delay or Control delay.
	Security Device	Curtain
	Close Anticipated (recommended)	Enable
	Unlock on standby	Enable
	Temperature measurement	Enable
Energy limit	Enable	

Menu	Option	Configuration to comply with EN81-20
Programming parameters	Max. open torque	Limit only in case of a glass door. If glass door the value must be up to 1,2.
	Max. close torque	Up to 1,2.
	Door mass	Masses of the door and landing door. To know check Annex 1 and Annex 2.

8.2 Light curtain

- The light curtain is mandatory and it can be connected to the lift controller or to the VF7+ Relay in the pin 21.
- In case of failure or deactivation of the light curtain the kinetic energy of the doors must be limited to 4J. To limit it the lift controller has to activate the slow close input, pin 25, of VF7+ Relay.

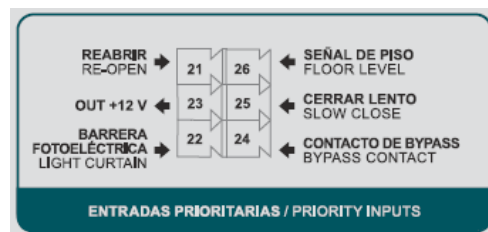

8.3 Overheating protection

- The internal temperature of the PM motor is measured by the VF7+ Relay when the option of "Temperature measurement" inside the "Programming options" menu is enabled.

8.4 Door contact

- A separate monitoring signal is necessary to check that the car door(s) is/are in the closed position. To comply this point an additional door contact is added, and the signal should be connected to the lift controller.

The maximum contact rating is 2 A 230 Vac.

9 Reference data

Electrical characteristics				
	Minimum	Nominal	Maximum	Units
Voltage input rating:	100	230	300	V AC
Frequency rating:	50	-	60	Hz

Protection requirements				
Protective class:	Protective Class I ⁽¹⁾			
Residual-current device [RCD]	RCD Type A [Recommended]			
Over-voltage category	Over-voltage category III			
Electrical supply system:	Supply earthing systems TT, NT, IT, not corner-earthed.			
Short-circuit current rating [SCCR]:	-	-	1,5	kA
IP rating:	-	-	20	

1. The accessible connections and parts listed below are of protective class 0. It means that the protection of these circuits relies only upon basic insulation and becomes hazardous in the event of a failure of the basic insulation. Therefore, devices connected to these circuits must provide electrical-shock protection as if the device was connected to supply mains voltage. In addition, during installation these parts must be considered, in relation with electrical shock, as supply mains voltage circuits.

Class 0 circuits:

INPUTS 8, 9, 10, 11, 12.
SERIAL COMMUNICATION 13.
PRIORITY INPUTS 21, 22, 23, 24, 25, 26.
MOTOR ENCODER 55.

Environmental characteristics				
	Minimum	Nominal	Maximum	Units
Humidity	-	-	95	%
Altitude	-	-	2000	m
Pollution degree	-	-	2	
Enclosure details	PPH + 20% TALC			

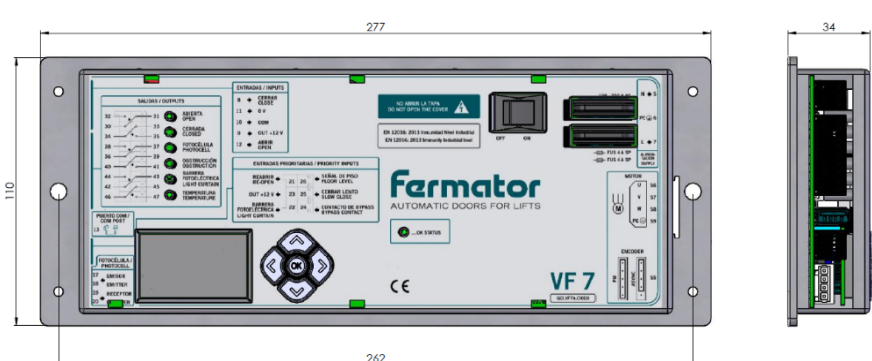
Mechanical characteristics				
				
Dimensions	L: 278 mm	W: 123 mm	D: 34 mm	
Mass	1,59 kg			

INSTRUCTIONS
DOC-FE.IE.IN.Draft.EN
VF7+ Relay Electronic Module
Version: 0.3

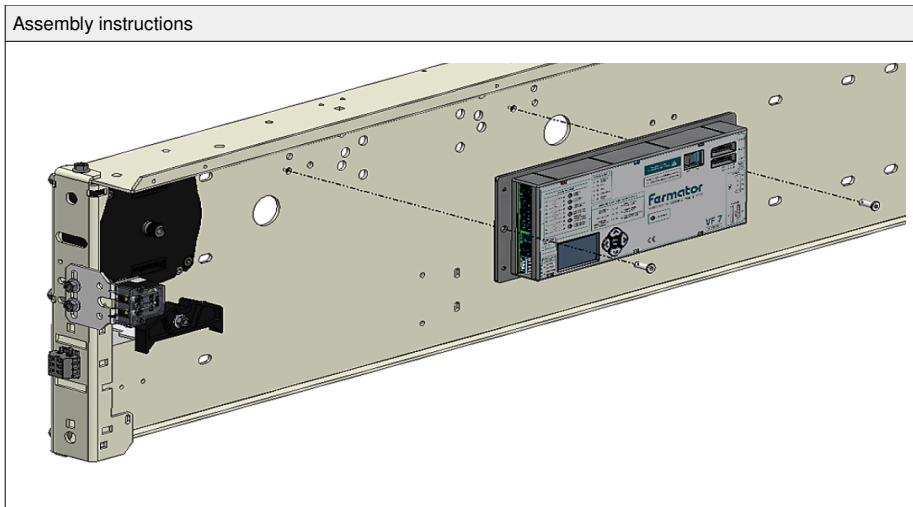

Motor PM requirements				
Type	Synchronous permanent magnet			
Number of poles	10			
Electrical characteristics				
	Minimum	Nominal	Maximum	Units
Voltage Supply	50	103	144	V
Current	0,18	1,13	2,13	A
Power	15	162	405	W
Torque	0	1,5	2,5	N·m
Speed	600			r.p.m.
Thermal class				
Encoder	Magnetic Incremental ABI (channel A, channel and index).			
Resolution	-	180	-	pulses / rev.

Wiring requirements for the female connectors				
	Minimum	Nominal	Maximum	Units
Power supply	0,2 / 25	-	2,5 / 14	mm ² / AWG
Inputs	0,25 / 24	-	1,5 / 16	mm ² / AWG
Priority inputs	0,25 / 24	-	1,5 / 16	mm ² / AWG
Outputs	0,25 / 24	-	1,5 / 16	mm ² / AWG
Motor power	-	0,75 / 18	-	mm ² / AWG
Motor Encoder	-	0,14 / 26	-	mm ² / AWG

Input signals	
Impedance	20 kΩ
Voltage	12 V DC to 60 V DC
	60 V AC to 125 V AC

INSTRUCTIONS
DOC-FE.IE.IN.Draft.EN
VF7+ Relay Electronic Module
Version: 0.3

Output signals				
	Minimum	Nominal	Maximum	Units
Contacts	Potential free contacts.			
Contact resistance	-	-	75	mΩ
Operate time	-	-	4	ms
Release time	-	-	4	ms
Current limit	-	-	150	mA
Voltage	-	-	250 / 200	V AC / V DC

Performance				
	Minimum	Nominal	Maximum	Units
Opening Speed	0,01	-	1,00	m/s
Closing Speed	0,01	-	0,60	m/s
Safety Force	60	-	150	N

10 Annex 1

10.1 Procedure calculation of moving mass

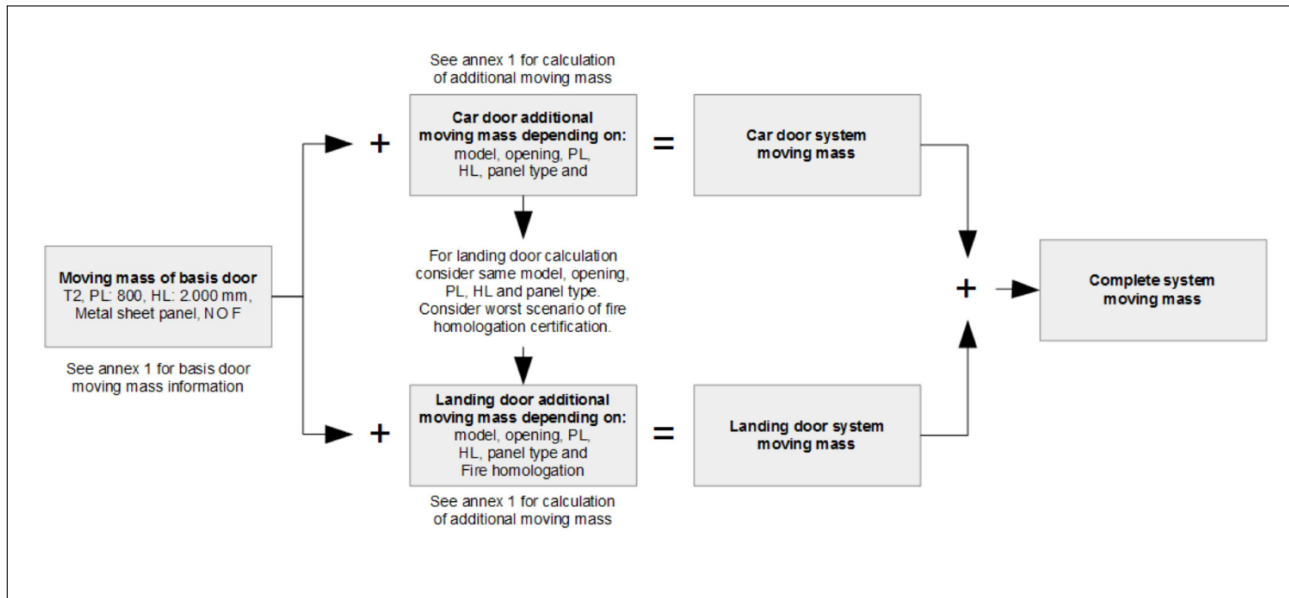

10.2 Compact product line

#	Model	Opening	Number of panels	PL [mm]	HL [mm]	Panel type	Fire homologation (*)	Moving mass [Kg]
0	Compact	Side	2	800	2000	Sheet metal	F.R. E 120	29,46

#	Concept	Multiplier factor
1	Difference from T2 to C2	0,02
2	Difference of 100 mm in PL	0,03
3	Difference of 100 mm in HL	0,01
4	Difference from F.R. E 120 to F.R. EI 60	0,16
5	Difference from F.R. E 120 to F.R. EI 120	0,20
6	Difference from F.R. E 120 to F.R. EW 60	0,12
7	Difference from F.R. E 120 to F.R. E 30 Russia	0,00
8	Difference from F.R. E 120 to F.R. EI 60 Russia	0,16
9	Difference from F.R. E 120 to F.R. EI 60 Ukraine	0,16
10	Difference from Sheet metal panels to Wien type vision panels	0,28
11	Difference from Sheet metal panels to Flush big vision panels	0,23
12	Difference from Metal Sheet metal to Full glass in skirting panels	0,07
13	Difference from Compact to Compact PM model	0,01
14	Difference from Compact to Compact+ PM 150 model	0,05

INSTRUCTIONS

DOC-FE.IE.IN.Draft.EN

VF7+ Relay Electronic Module

Version: 0.3

10.3 40/10 product line

#	Model	Opening	Number of panels	PL [mm]	HL [mm]	Panel type	Fire homologation	Moving mass [Kg]
0	40/10 PM	Side	2	800	2000	Sheet metal	F.R. E 120	31,93

#	Concept	Multiplier factor
1	Difference from T2 to T3	0,08
2	Difference from T2 to C2	0,00
3	Difference from T2 to C4	0,26
4	Difference of 100 mm in PL	0,07
5	Difference of 100 mm in HL	0,03
6	Difference from F.R. E 120 to F.R. EI 30	0,19
7	Difference from F.R. E 120 to F.R. EI 60	0,19
8	Difference from F.R. E 120 to F.R. EI 120	0,25
9	Difference from Sheet metal panels to Double skin panels	0,32
10	Difference from Sheet metal panels to Flush big vision panels	1,02
11	Difference from Sheet metal panels to Full glass in skirting panels	0,95
12	Difference from Sheet metal panels to Wien type vision panels	0,32
13	Difference from Sheet metal panels to Vision panels	0,61

10.4 Premium product line

#	Model	Opening	Number of panels	PL [mm]	HL [mm]	Panel type	Fire homologation	Moving mass [Kg]
0	Premium PM	Side	2	800	2000	Sheet metal	F.R. E 120	36,61

#	Concept	Multiplier factor
1	Difference from T2 to T3	0,07
2	Difference from T2 to T1	-0,17
3	Difference from T2 to C2	-0,03
4	Difference from T2 to C4	0,30
5	Difference from T2 to C6	1,15
6	Difference of 100 mm in PL	0,07
7	Difference of 100 mm in HL	0,11
8	Difference from F.R. E 120 to F.R. EI 30	0,18
9	Difference from F.R. E 120 to F.R. EI 60	0,18
10	Difference from F.R. E 120 to F.R. EI 120	0,24
11	Difference from Sheet metal panels to Double skin panels	0,12
12	Difference from Sheet metal panels to Flush big vision panels	0,60
13	Difference from Sheet metal panels to Full glass in skirting panels	0,60
14	Difference from Sheet metal panels to Foam filled panels	-0,17

INSTRUCTIONS

DOC-FE.IE.IN.Draft.EN

VF7+ Relay Electronic Module

Version: 0.3

10.5 Platinum product line

#	Model	Opening	Number of panels	PL [mm]	HL [mm]	Panel type	Fire homologation	Moving mass [Kg]
0	Platinum PM	Side	2	800	2000	Double skin	F.R. E 120	56,85

#	Concept	Multiplier factor
1	Difference from T2 to C2	0,06
2	Difference of 100 mm in PL	0,08
3	Difference of 100 mm in HL	0,07

INSTRUCTIONS

DOC-FE.IE.IN.Draft.EN

VF7+ Relay Electronic Module

Version: 0.3

11 Annex 2

11.1 Example 1: Increment of PL and HL

Door to be calculated:						
Model	Opening	Number of panels	PL [mm]	HL [mm]	Panel type	Fire protection
40/10 PM	Side	2	900	2.100	Sheet metal	F.R. E 120

Taking as basis ⁽¹⁾ :							
Model	Opening	Number of panels	PL [mm]	HL [mm]	Panel type	Fire homologation	Moving mass [Kg]
40/10 PM	Side	2	800	2.000	Sheet metal	F.R. E 120	31,93

Calculations:							
Difference per opening	Difference per number of panels	Difference per PL (each 100 mm)	Difference per HL (each 100 mm)	Difference per panel type	Difference per fire homologation	SUM	Moving mass
There are equals	There are equals	$31,93 \times 0,07^{(2)} = 2,23 \text{ Kg}$	$31,93 \times 0,03^{(3)} = 0,95 \text{ Kg}$	There are equals	There are equals	$2,23 + 0,95 = 3,18$	$31,93 + 3,18 = 35,11 \text{ Kg}$

1. These specifications are in the Annex 1.
2. This factor is the increment of 100mm in PL. There is the number 4 of the second table of 40/10 PM in the Annex 1.
3. This factor is the increment of 100mm in HL. There is the number 5 of the second table of 40/10 PM in the Annex 1.

11.2 Example 2: Difference of opening and number of panels + increment of PL and HL

Door to be calculated:						
Model	Opening	Number of panels	PL [mm]	HL [mm]	Panel type	Fire protection
Premium PM	Side	1	800	2.000	Double skin	F.R. E 120

Taking as basis ⁽¹⁾ :							
Model	Opening	Number of panels	PL [mm]	HL [mm]	Panel type	Fire homologation	Moving mass [Kg]
Premium PM	Side	2	800	2.000	Sheet metal	F.R. E 120	36,61

Calculations:							
Difference per opening ⁽²⁾	Difference per number of panels ⁽²⁾	Difference per PL (each 100 mm)	Difference per HL (each 100 mm)	Difference per panel type ⁽³⁾	Difference per fire homologation	SUM	Moving mass
$36,61 \times (-0,17) = -6,13 \text{ Kg}$	There are equals	There are equals	There are equals	$36,61 \times 0,12 = 4,39 \text{ Kg}$	There are equals	$4,39 - 6,13 = -1,74 \text{ Kg}$	$36,61 - 1,74 = 34,87 \text{ Kg}$

1. These specifications are in the Annex 1.
2. This factor is the difference between T2 (side 2 panels) to T1 (side 1 panel). There is the number 2 of the second table of Premium PM in the Annex 1.
3. This factor is the difference between Sheet metal panel and double skin panel. There is the number 11 of the second table of Premium PM in the Annex 1

12 Annex 3

12.1 Reduction, Clutch length and Pinion Perimeter

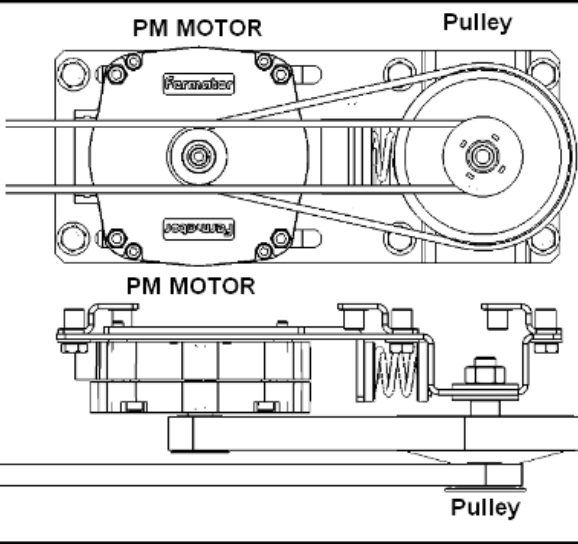
	<p>Gear Ratio 1:3.21</p>
	<p>Clutch Length 0.052 m</p>
	<p>Pinion Perimeter 131 mm</p>
<p>Premium PM with manufacture date ≤ 12/2016</p>	

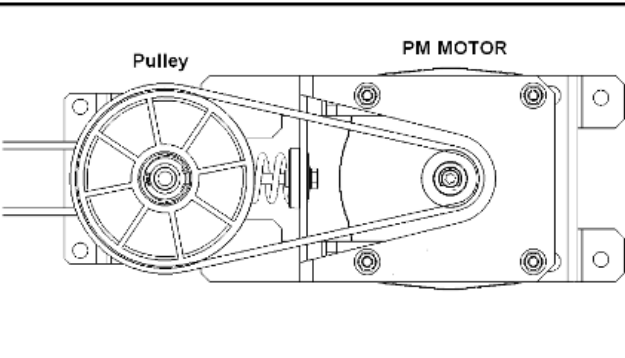
	<p>Gear Ratio 1:2.67</p>
	<p>Clutch Length 0.052 m</p>
	<p>Pinion Perimeter 106 mm</p>
<p>Premium PM with manufacture date ≥ 01/2017</p>	

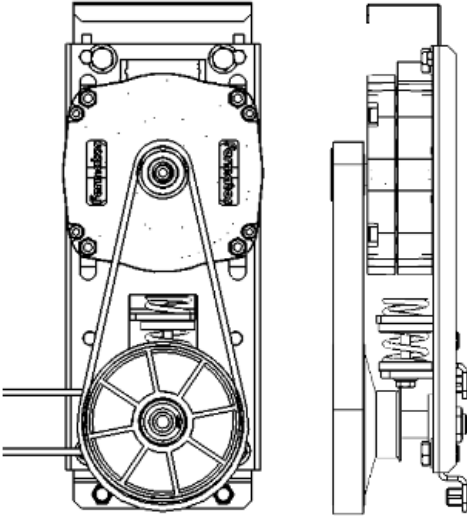
	<p>Gear Ratio</p> <p>1:2.67</p>
	<p>Clutch Length</p> <p>0.052 m</p>
	<p>Pinion Perimeter</p> <p>106 mm</p>
<p>Premium PM with manufacture date \geq 01/2017</p>	

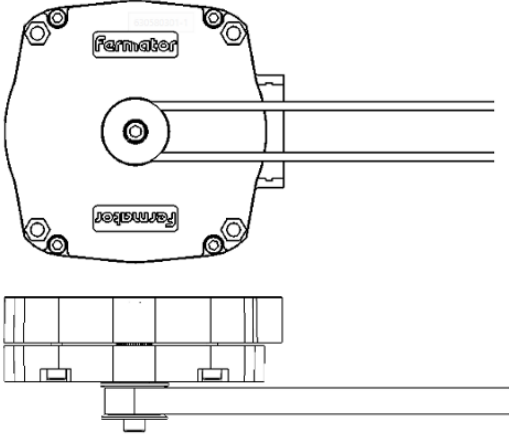
<p>PM MOTOR</p> 	<p>Gear Ratio</p> <p>1:1</p>
	<p>Clutch Length</p> <p>50-11 PM SLIM ==>> 0.030m Other doors ==>> 0.052 m</p>
	<p>Pinion Perimeter</p> <p>80 mm</p>

13 Annex 4

13.1 Graphic Interface map

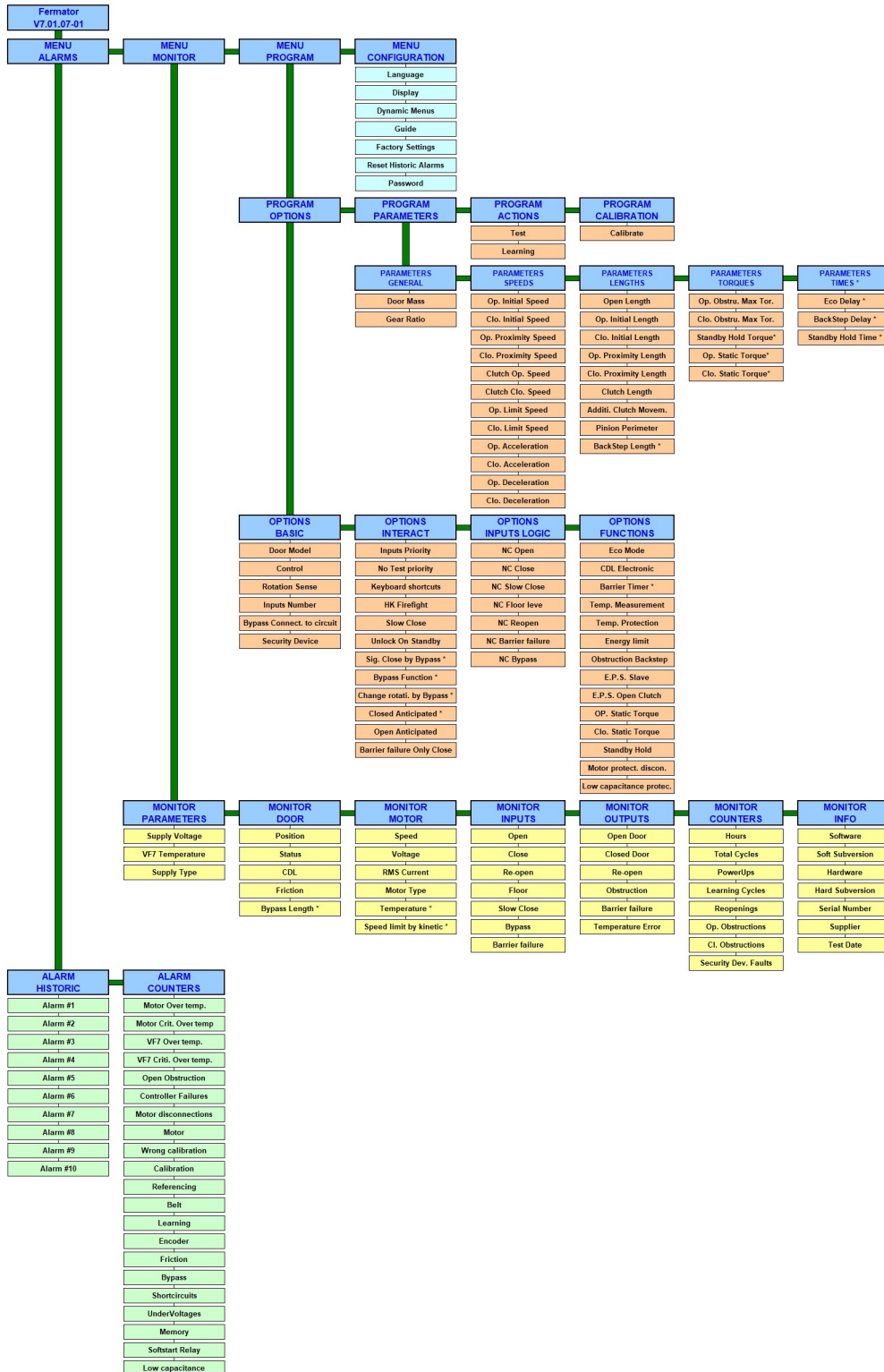

* These options and parameters can be hidden depending on what options are disabled.