

HYDRONIC 300 MODPAC “MULTIPURPOSE KIT” 650921G05

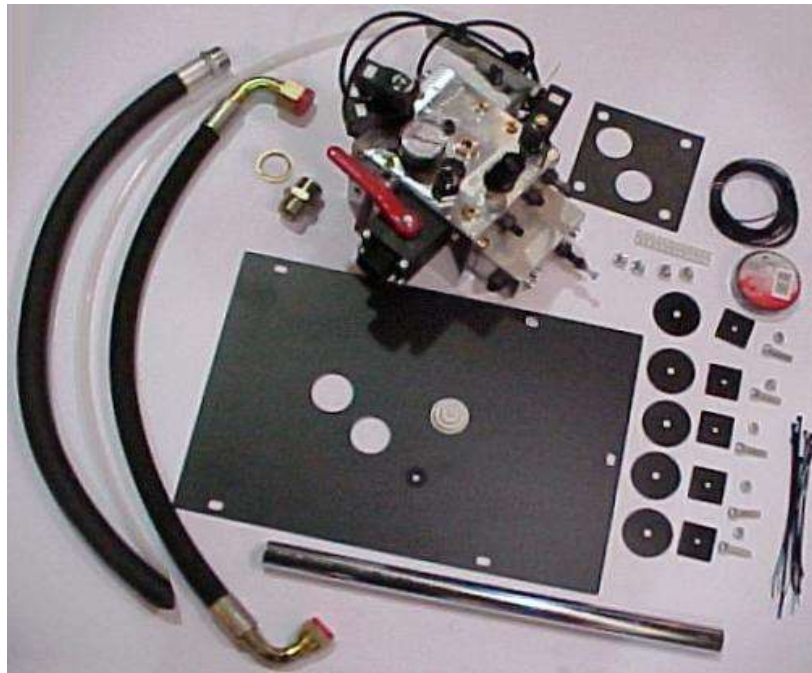

Contents:

- List of provided material
- Assembly instructions
- No. 1933 assembly drawing
- H300 – HL 07.02 electric working description
- H300 – HL 07.03 oil-dynamic scheme
- H300 – HL 07.05 hydraulic working description
- H300 – HL 07.06 calibration instructions
- General instructions to adjust H300 – HL 07.07 valve parameters

List of provided standard material

- No. 1 complete Hydronic 300 valve
- No. 1 rubber gasket (fixing plate / H300 valve)
- No. 4 M10 x 14 UNI 5739 screws
- No. 1 nipple 1" gas
- No. 1 bonded seals 1"
- No. 1 flex hose for oil flow (screw pump / H300 valve)
- Adapters to connect flex hose to screw pump
- No. 1 oil outlet pipe
- No. 1 stepped gland for solenoid valve cables
- No. 1 electric material kit
- Solenoid valve / pressure switch connecting cables, standard length 2000 mm
- Valve fixing plate on existing lid together with clamping screws

Assembly instructions

- Remove the old valve and the oil inlet pipe connected to the silencer/pump from the tank
- Find the most suitable position to place H300 valve on the tank cover
- Use H300 valve fixing plate as drilling template for the tank cover
- Complete H300 valve (1 pos.) with:
 - 1" nipple and bonded seals (7,8 pos.) in the valve oil inlet hole (P position, 1933 drawing)
 - outlet pipe (9 pos.) in the oil outlet hole (T pos., 1933 drawing)
 - hand pump hose together with rubber stepped gland top (2,3 pos. if foreseen)
 - connect oil inlet pipe (13 pos.) to 1"nipple (8 pos.)
- Assembly H300 valve on the plate (10 pos.) with screws and nuts (11 and 12 pos.) putting in the rubber gasket (10 pos.).
- Connect oil flow hose (13 pos.) to the pump inside the tank
- Connect solenoid valve and pressure switch cables to the existing connection box inside the tank, using the provided rubber stepped gland, if necessary.

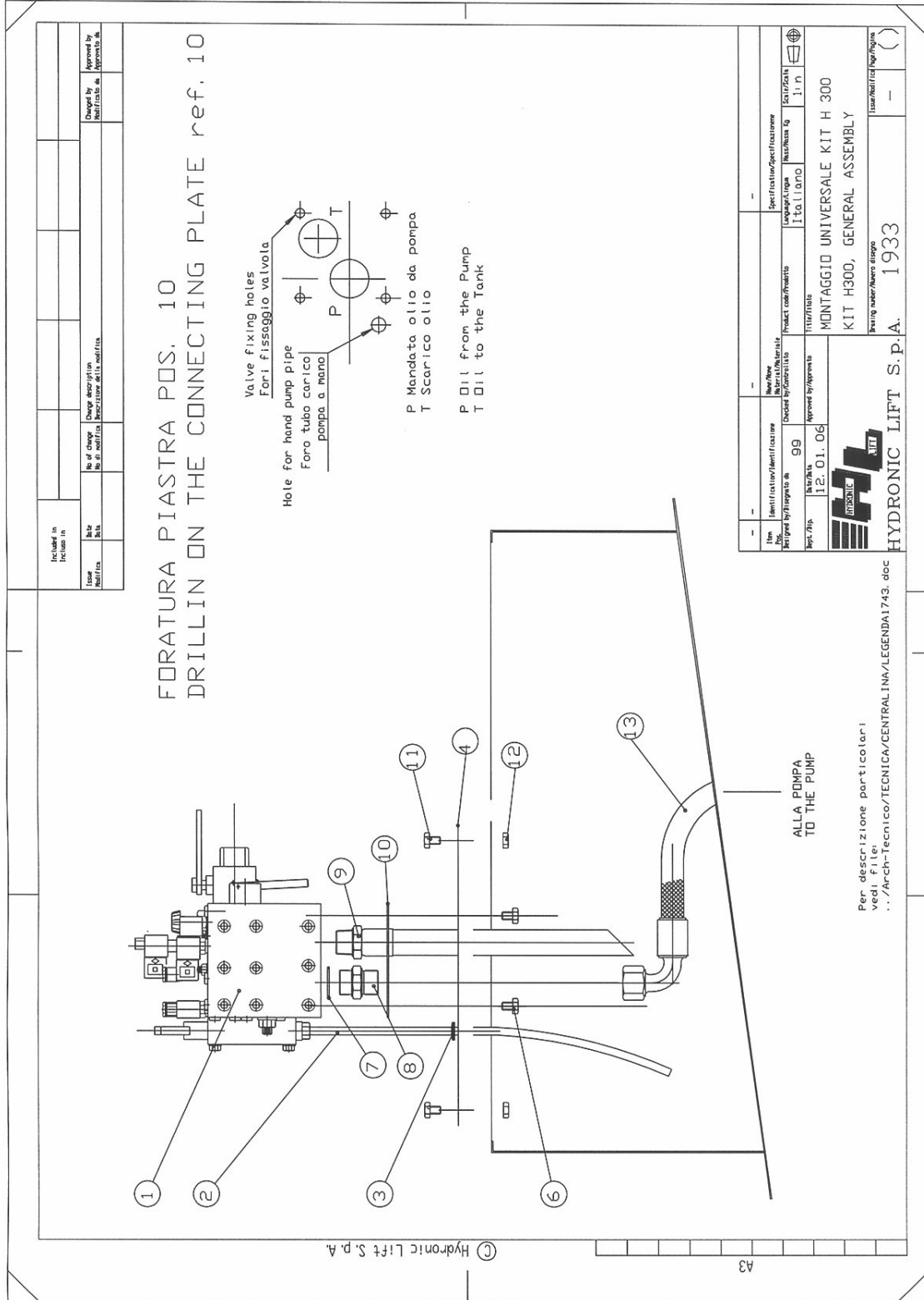

1933 DRAWING LEGEND - H300 "MULTIPURPOSE KIT"

1. Complete H300 valve in accordance with EN 81-2 with solenoid valve harness
2. Hand pump suction pipe
3. Rubber stepped gland for hand pump suction pipe
4. Valve fixing plate
- 5.
6. H300 valve fixing screws
7. 1" bonded seals
8. 1" nipple
9. Oil outlet hose
10. H300 rubber gasket
11. Plate fixing screws
12. Nuts
13. 1" flex hose screw pump/valve connection

FUNCTION DESCRIPTION

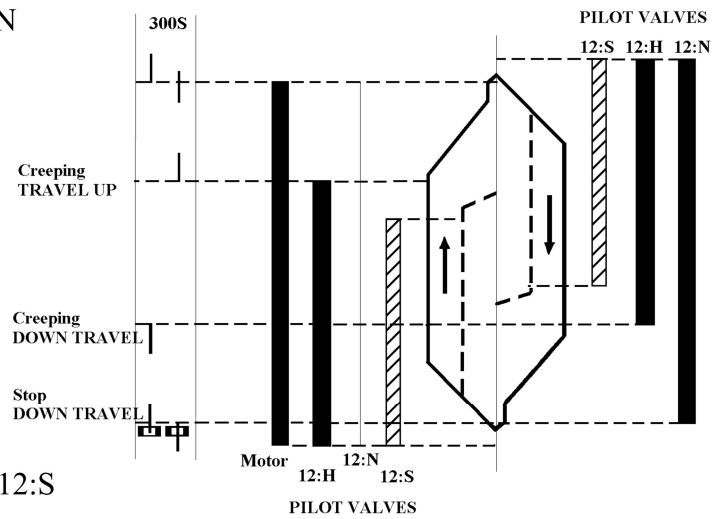
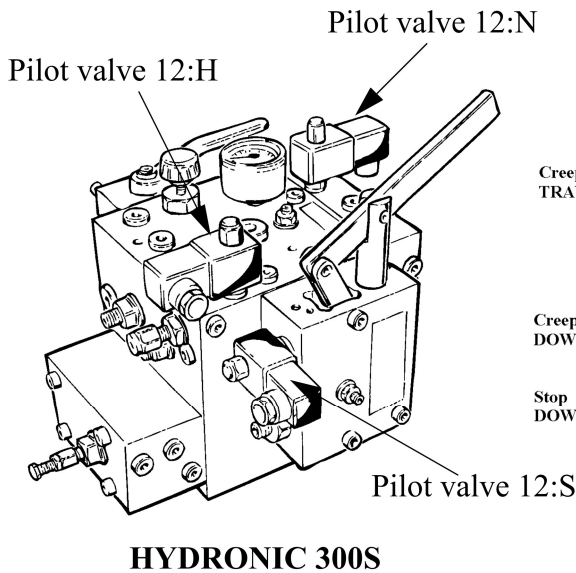
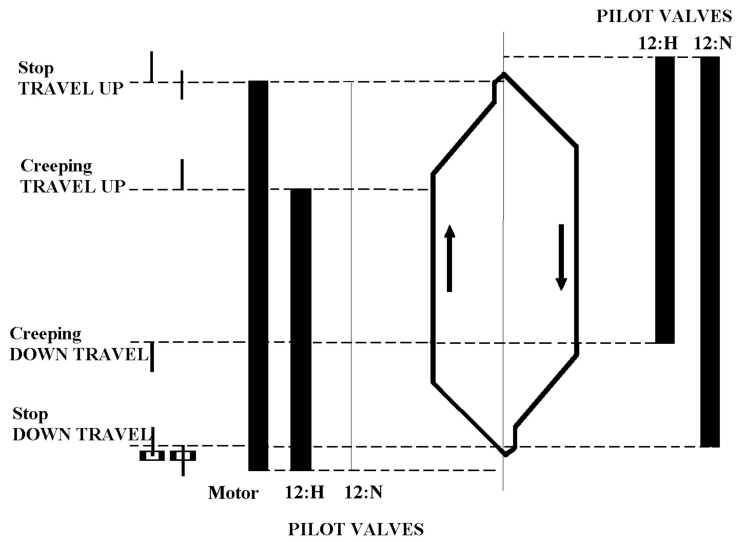
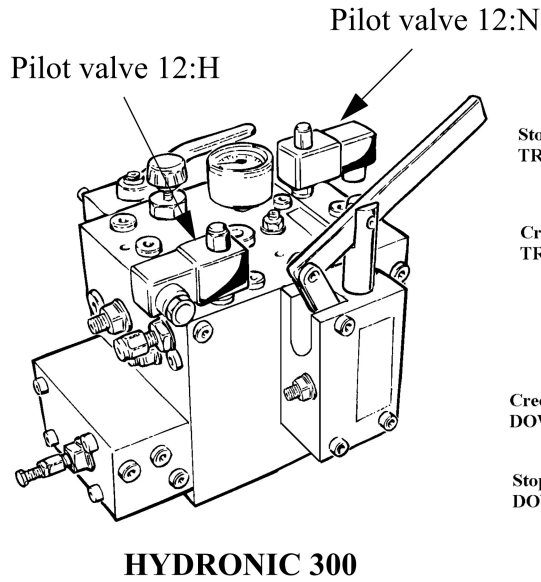

Pilot valve 12:S for service drive is compulsory for elevators with speed over 0,63 m/s.
 When using service drive, the pilot valve 12:H is not energized.

Principal diagram for HYDRONIC 300

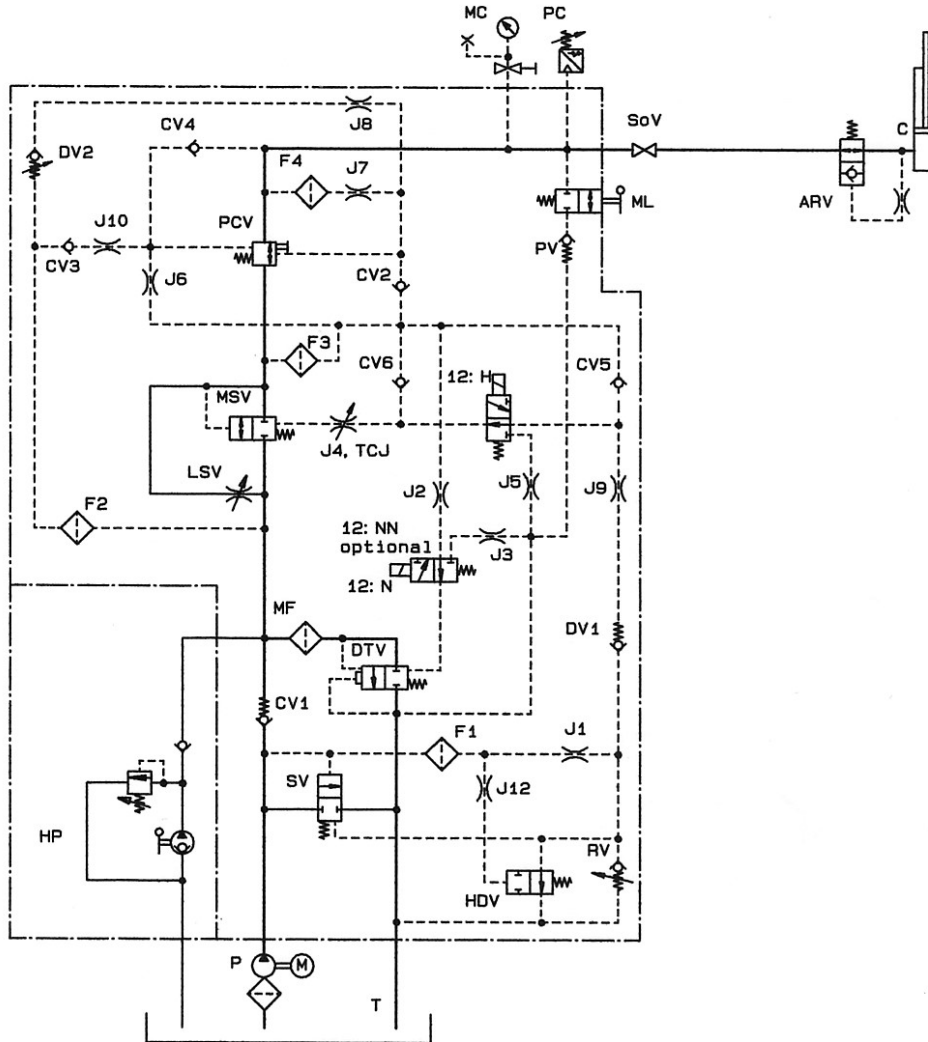

- | | | | |
|------------|---|--------------|---------------------------------------|
| M | Motor | SoV | Shut-off valve |
| P | Pump | PCV | Pressure compensator valve |
| T | Tank | DTV | Down travel valve |
| C | Cylinder | RV | Relief valve |
| MC | Manometer | PV | Pressure valve (indirect drive) |
| ML | Manual lowering valve | CV1-6 | Check valve |
| HP | Hand pump | DV1-2 | Pressure difference valve |
| PC | Pressure switch | HDV | Hydraulic delay valve |
| SV | Start valve | J1-12 | Jets |
| MSV | Main speed valve | F1-4 | Filters |
| LSV | Levelling speed valve | 12:H | Pilot valve for nominal speed |
| TCJ | Temp. controlled needle valve
(for HYDRONIC300 as an option) | 12:N | Pilot valve for down travel |
| | | 12:NN | Emergency pilot valve for down travel |
| | | ARV | Automatic rupture valve |



HL 07.05-1/3

Rev: A

Data: 11-98

FUNCTION DESCRIPTION VALVE HYDRONIC 300

THE ELEVATOR STANDS AT FLOOR LEVEL

All the spools and pilot valves are in the ideal position when the elevator stands at floor level. The components, which are tight against leakage and keep the elevator car at floor level, are:

check valve 1	CV1
down travel valve	DTV
pressure difference valve 1	DV1
manual lowering valve	ML
pilot valve for nominal speed	12:H
pilot valve for down travel	12:N
pilot valve for service speed	12:S

and of course all the static seals must be in order.



HL 07.05-2/3

Rev: A

Data: 11-98

UP TRAVEL

Start

Pump motor and pilot valve 12:H are activated.

Oil flow from the pump pushes the start valve **SV** open and goes back to the tank. The motor reaches the nominal speed “compressing” the oil to by pass pressure (**SV** is wide open).

After a short time delay, which depends on **J12**, **HDV** closes.

This delay enables the star/delta motor starting and eliminates the need of a specific pilot valve.

Pilot valve **12:H** is activated and the main speed valve **MSV** starts to open.

The start valve **SV** closes with constant speed determined by the spring and the jet **J1** increasing the pressure inside the chamber in front of **CV1**.

Acceleration

When it is higher than the load pressure, the pressure pushes **CV1** and the compensator valve **PCV**, to the open position. The elevator begins to accelerate due to oil flow through the check valve, the main speed valve and **PCV** to the cylinder line.

Nominal speed

When **SV** is completely closed, the whole flow from the pump goes to the cylinder and the elevator drives up at the nominal speed.

The still activated **12:H** pilot valve keeps **MSV** wide open.

Deceleration

When the elevator arrives at the deceleration vane, the pilot valve **12:H** drops, **SV** gradually closes, thanks to **J1**, **DV1**, **J9**, **J4** while deceleration is actuated by the gradual closing of **MSV** valve.

Levelling speed

After **MSV** has closed completely, a little portion of the flow reaches the jack through levelling valve **LSV** while the bigger part will come back to the tank through **SV**, and the car will climb at levelling speed.

Stop

When the elevator car arrives at the floor level vane, the motor is switched off.

Inertia of the motor and the flywheel makes the elevator stop smoothly.

While the pump retards, **SV**, **CV1** and **PCV** close to the position they had before start up.

the route through **CV3** and **J10** is provided for speeding up the closing of **PCV** after the elevator has stopped.



HL 07.05-3/3

Rev: A

Data: 11-98

DOWN TRAVEL

Start

The pilot valves, **12:H** e **12:N** are activated, this causes the opening of the down travel valve **DTV**, **MSV** and **PCV**.

Acceleration

MSV, slowed by jets **J4** and **J5**, opens gradually until it's wide open and the car accelerates until it reaches the max speed.

Nominal speed

MSV is wide open, **PCV** regulates the oil flow and therefore the car speed, thanks to the pressure balance created by **J6**, **J7**, **DV2** (last one is adjustable)

Deceleration

When the car reaches the slowing vane, **12:H** is deactivated, **MSV** start closing, slowed by **J4**, and the car decelerates.

Again **PCV** keeps the pressure drop over **MSV** constant and the elevator decelerates to the levelling speed as **MSV** closes.



Levelling speed

MSV is fully closed, oil flows just through **LSV**, and the car goes down slowly. **PCV** regulates oil flow according to car load.

Stop

Finally **12:N** is de-energized. the down travel valve **DTV** start closing and the elevator stops smoothly. The pressure compensator valve **PCV** closes too and the elevator is ready for the next travel.

INSTRUCTION FOR ADJUSTMENT

	Elevator movement	Change	Procedure	Remarks
UP 	Acceleration	Slower	Screw 2 ↻	
		Faster	Screw 2 ↻	
	Elevator speed			Not adjustable
	Deceleration up and down	Softer	Screw 4 ↻	1/6 turn at time
	Levelling speed	Increased	Screw 5 ↻	Common for up and down. Normally c:a 0,05 m/sec
		Decreased	Screw 5 ↻	
Stop	Levelling	Adjusted with shaft vane	Vane ~ 30 mm from floor level	
DOWN 	Acceleration			Not adjustable
	Elevator speed	Increased	Screw 6 ↻	Normally equal with speed in up direction
		Decreased	Screw 6 ↻	
	Deceleration up and down	Softer	Screw 4 ↻	1/6 turn at time
	Levelling speed	Increased	Screw 5 ↻	Common for up and down. Normally c:a 0,05 m/sec
		Decreased	Screw 5 ↻	
Stop	Levelling	Adjusted with shaft vane	Vane ~ 30 mm from floor level	
	Over pressure	Higher pressure	Screw 1 ↻	Adjusted to 140% max. static pressure
		Lower pressure	Screw 1 ↻	

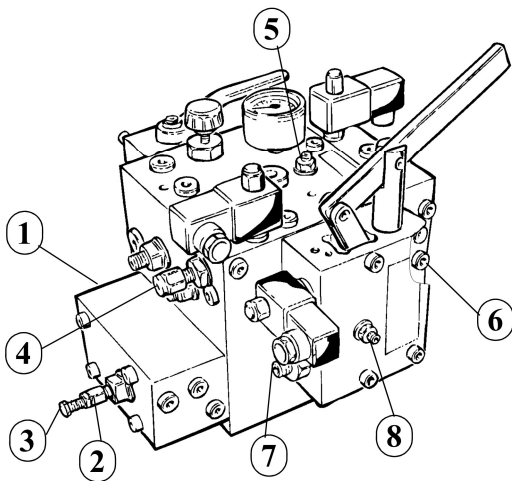

1. Adjustment screw for over pressure
2. Adjustment screw for acceleration up
3. Adjustment screw for by-pass pressure
4. Adjustment screw for deceleration up and down (for HYDRONIC 300 as an option)
5. Adjustment screw for levelling speed up and down
6. Adjustment screw for elevator speed down
7. Adjustment screw for hand pump pressure
8. Adjustment for service speed (only for HYDRONIC 300S)

INSTRUCTION FOR HYDRONIC 300 ADJUSTMENT

NOTE: open the manometershut off valve only during the adjustment of the Hydronic valve. During the normal lift work the manometer shut off valve must be closed.

By-pass pressure

The by-pass pressure is adjusted at the factory. It is readjusted only if start delay time needs adjustment. The by-pass flow pressure must be equal or slightly less than empty car static pressure. Too low by-pass pressure causes extra delay during up start or a little car sink before up start.

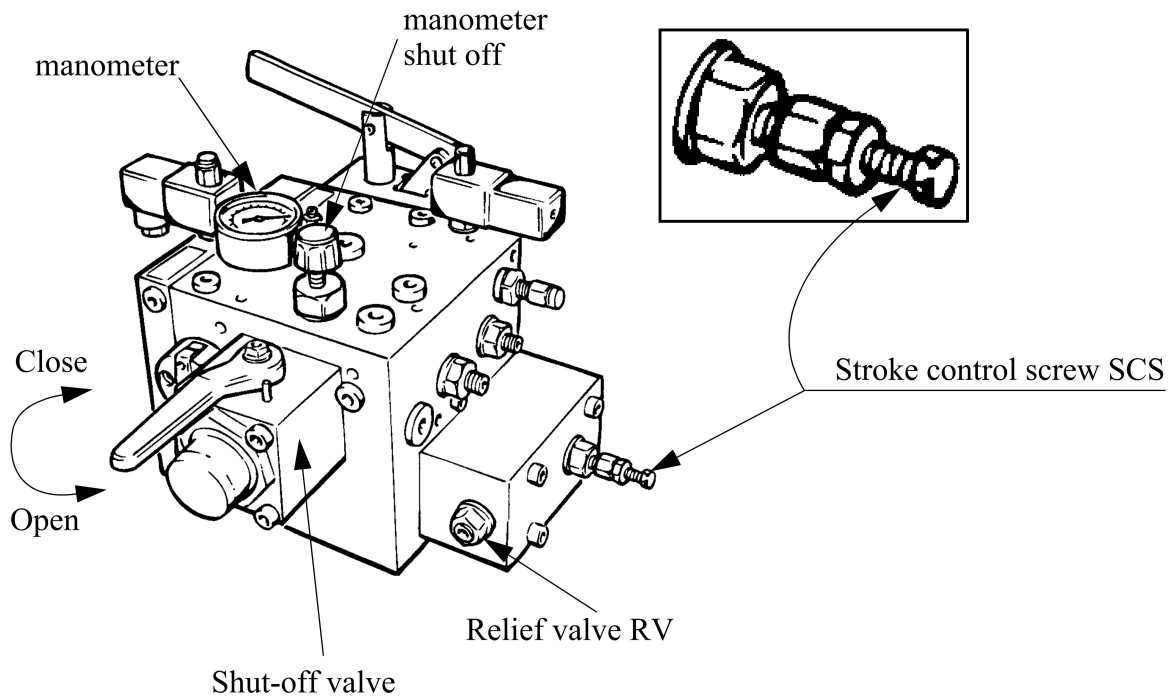

Tools:

- socket head wrench 5 and 6 mm
- spanner 10 mm 13 mm 19 mm

Adjustment of by-pass pressure:

- Close the shut-off valve.
- Open the relief valve (RV) so much that there is no spring force.
- Start the elevator for up travel.
- Adjust the stroke control screw (SCS) until the manometer indicates about the min static pressure with empty car. (turning the screw clockwise increases the by-pass pressure)
- secure the adjustment with the lock nut.
- Adjust the over pressure.

Over pressure

The over pressure (140% of the max static pressure) is adjusted at the factory. It is readjusted only, if the relief valve (RV) has been repaired or if its adjustment has been altered for some reason.

Max. working pressure = car with full load, travelling up (dynamic pressure).

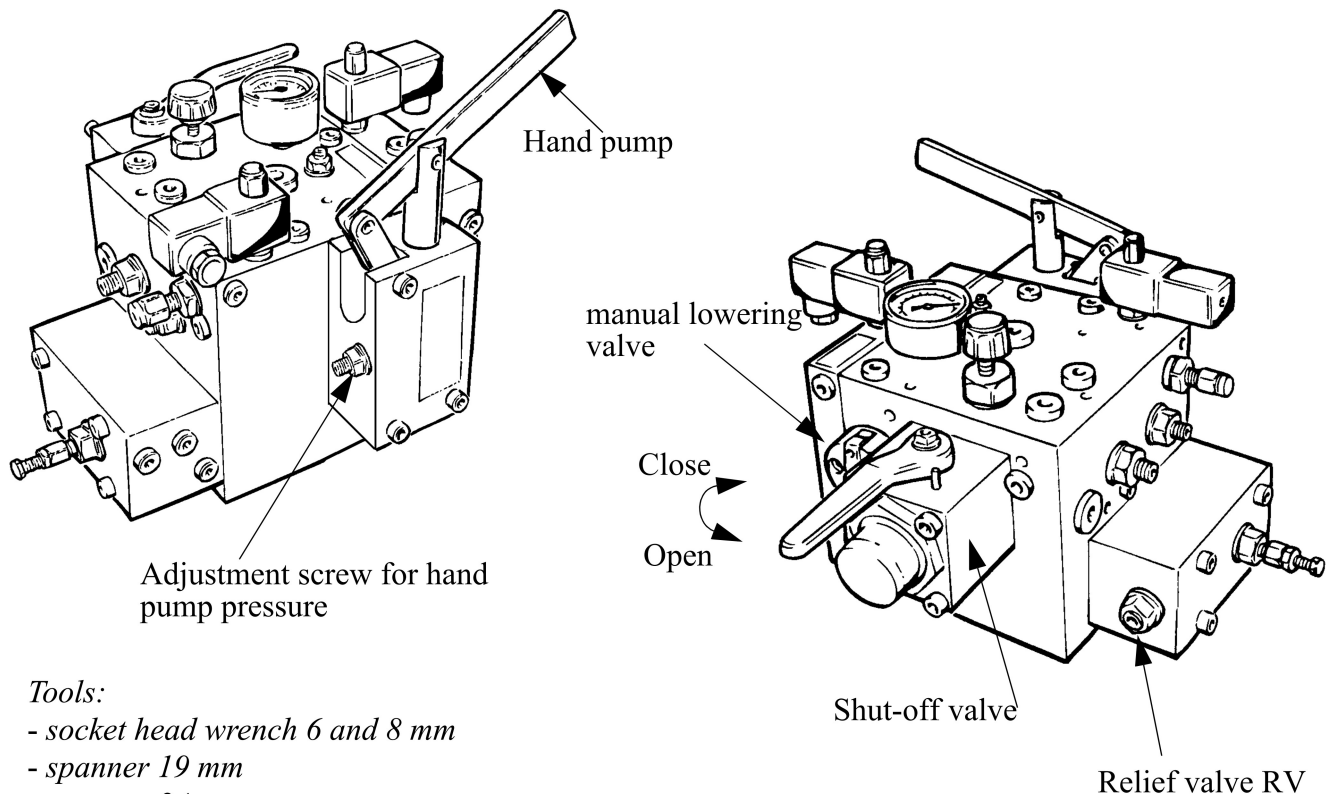

Tools:

- socket head wrench 6 and 8 mm
- spanner 19 mm
- spanner 24 mm

Adjustment of over pressure:

Relief valve RV

- Close the shut-off valve.
- Start the elevator for up travel.
- Turn the adjustment screw of the relief valve (RV) until the manometer shows the correct pressure (140% of the max. static pressure).
- Lock the adjustment with lock nut.

Hand pump

- Close the shut-off valve.
- Pump up the pressure with the hand pump and read the value from the manometer.
- Adjust the hand pump pressure screw if the value is less than the over pressure (the value must not exceed 2.3 times the full load static pressure).
- Lock the adjustment with lock nut.

Acceleration up

The start valve (SV) spring force must be adjusted so that the elevator has a comfortable acceleration.

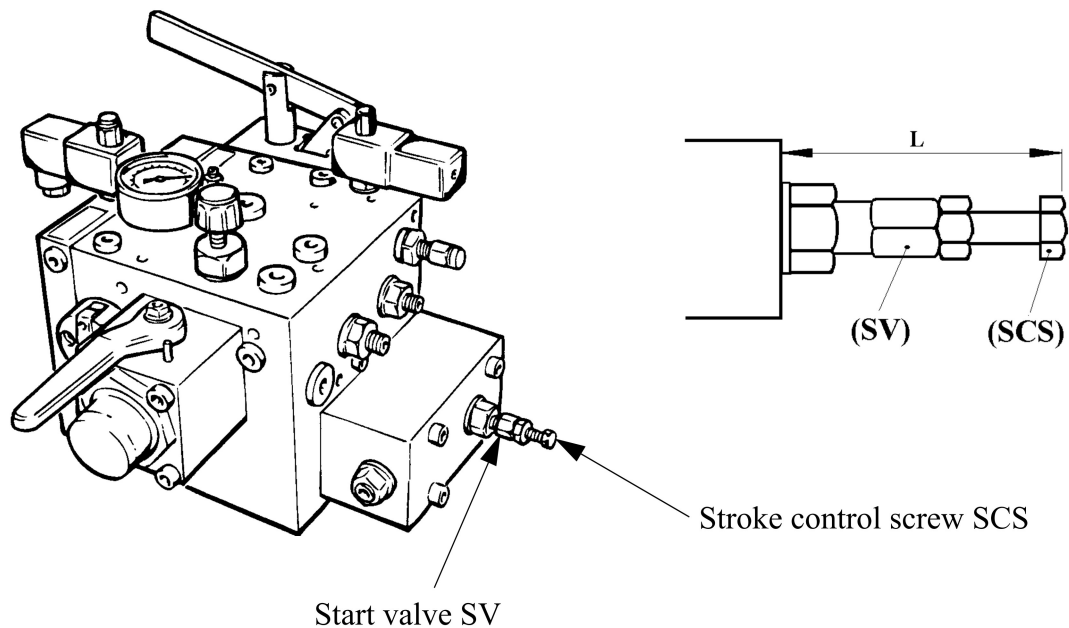

Tools:

- spanner 5 mm, 10 mm, 13 mm, 19 mm

Adjustment of acceleration up:

- Measure the length L of the stroke control screw (SCS) (see picture).
- Start the elevator to up-direction and observe the acceleration.
- Turn the black adjusting screw of the start valve (SV) **anti-clockwise**, if the acceleration is too hard, or **clockwise** if the acceleration is too slow.
- Lock the adjustment with lock nut.
- Re-adjust the stroke control screw (SCS) to the measured length L.
- Listen and make sure that the by-pass flow is completely stopped within 2.5....3 seconds.
(If not, increase the acceleration up. Also check the by-pass pressure)

Deceleration up and down

Deceleration is controlled with TCJ, which with J4 forms a needle valve.

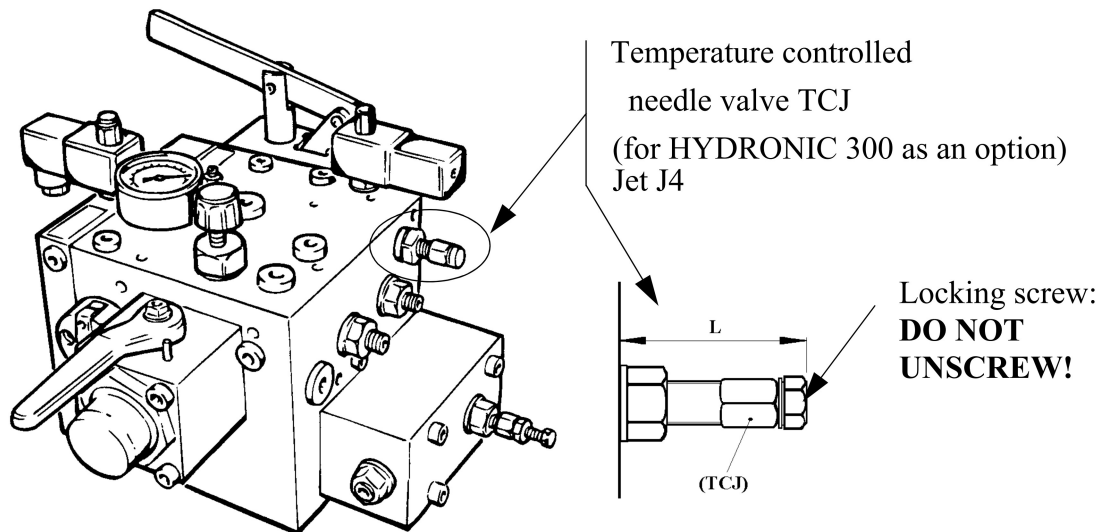

Tools:

- *Spanner 13 mm e 19 mm*

Reference dimension L: 40 mm

Adjustment of deceleration:

- Drive the elevator in up-direction and observe the deceleration and charge-over to the levelling speed.
- Turn the adjustment screw of TCJ **clockwise** to get a smoother deceleration and **anti-clockwise** for harder deceleration.
(Attention: turn only 1/6 of a turn at a time; screwing the needle valve too far inwards can destroy the valve).
- Lock the adjustment with lock nut.

Nominal speed down

The adjustment of the pressure difference (DV2) for nominal speed in down-direction must be always. (Normally, the elevator speed has to be equal in both up and down direction).

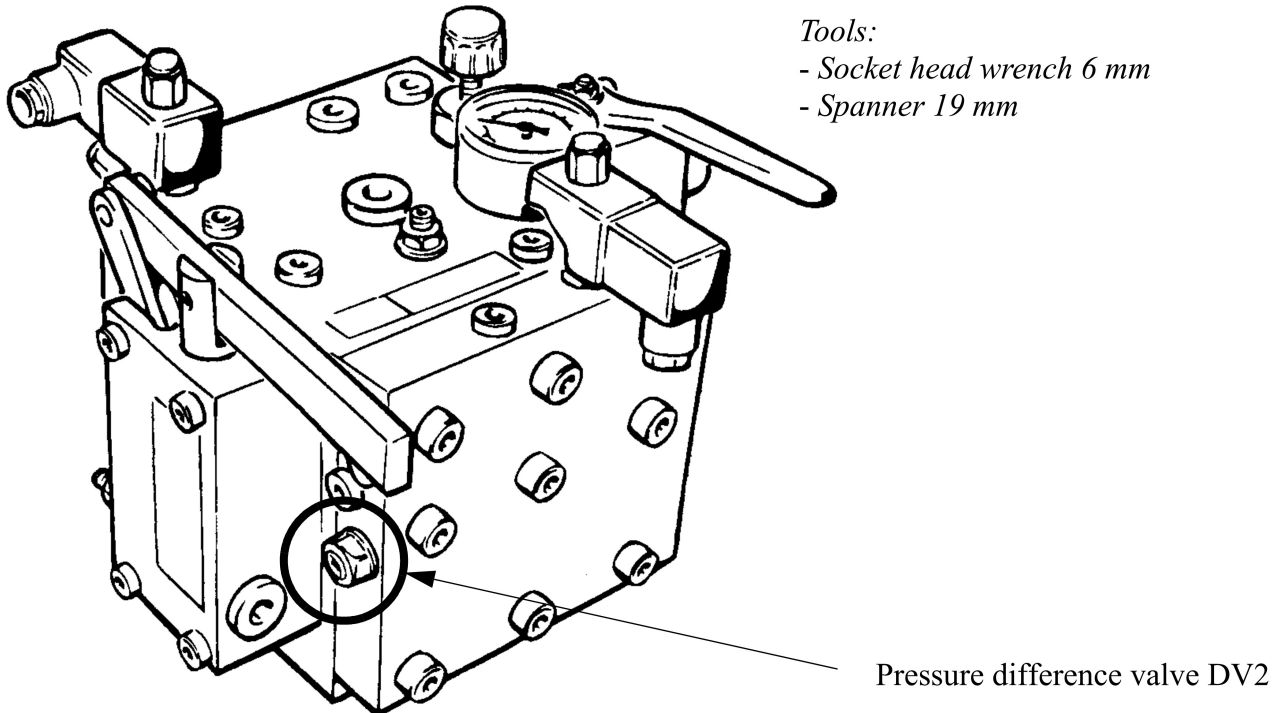

Adjustment of nominal speed down:

- Drive the elevator in up-direction and measure the elevator speed with a tachometer or a clock (stop-watch).
- Drive the elevator in down-direction and measure the speed as in up-direction. Compare the results.
- Turn the adjustment screw of the pressure difference valve **clockwise** for speed increase or **anti-clockwise** for speed decrease.
- Lock the adjustment with the lock nut.

Levelling speed

The levelling speed valve (LSV), which is common for the levelling speeds in both up- and down-direction, is pre-adjusted at the factory. therefore, only a fine-adjustment is carried out at the site.

The levelling speed must be adjusted so that the final stop is comfortable. As too low levelling speed can cause vibrations (stick-slip effect).

Levelling speed valve LSV

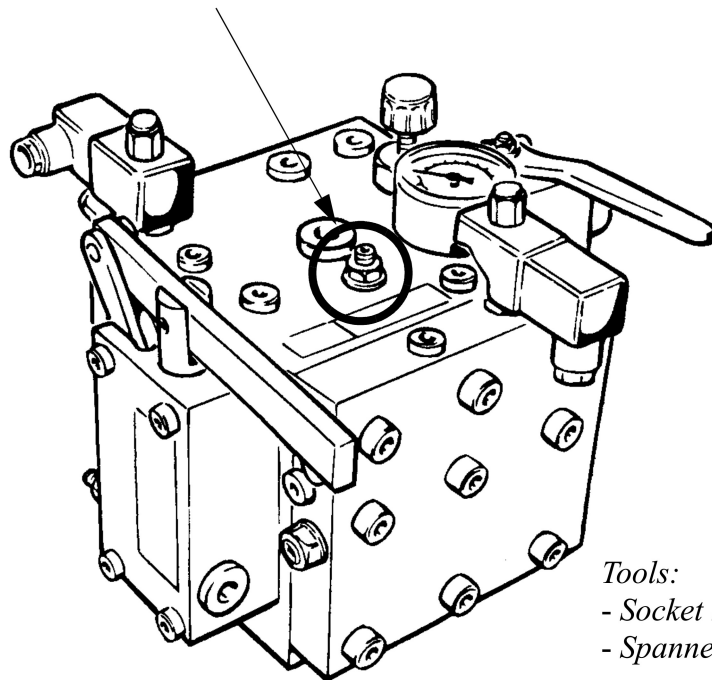

Tools:

- Socket head wrench 4 mm
- Spanner 13 mm

Adjustment of levelling speed:

- Turn the adjusting screw of the levelling speed valve **anti-clockwise** in order to gain a higher speed or **clockwise** for a lower speed.
- Check the levelling or **clockwise** for a lower speed.
- Lock the adjustment with the lock nut.

Service speed (only valid for HYDRONIC 300S)

The service speed valve (SSV), which is common for the service speeds in both up- and down-direction, is preadjusted in factory.

the service speed must not exceed 0,63 m/s.

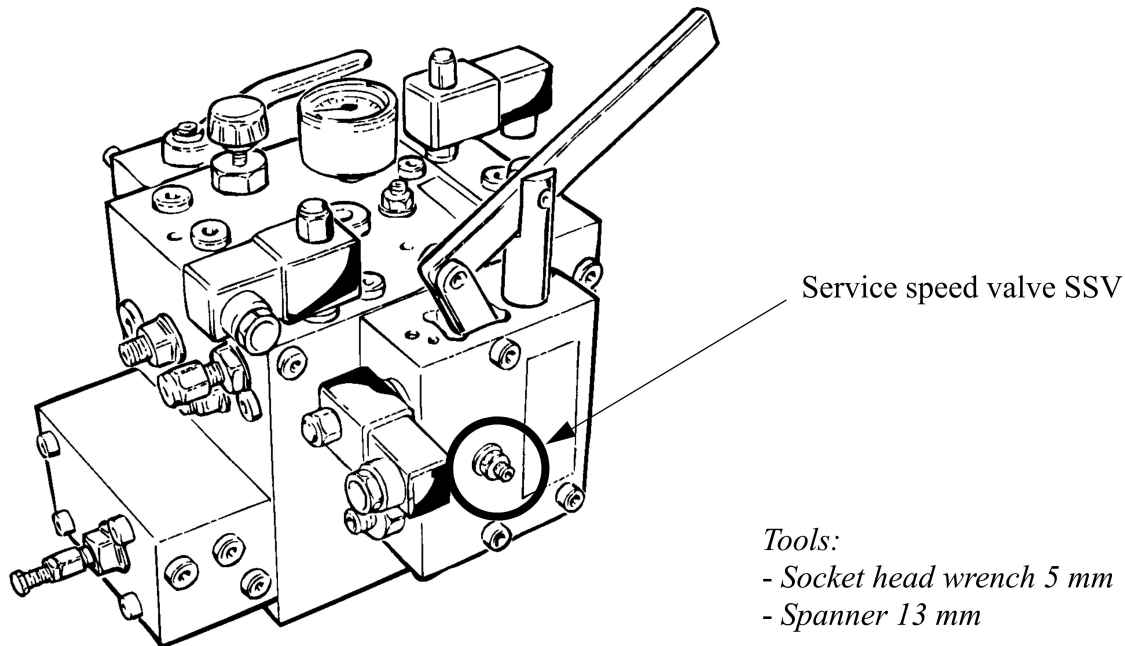

Adjustment of service speed:

- Turn the adjustment screw of the service speed valve (SSV) **anti-clockwise** in order to gain a higher speed or **clockwise** to reduce the speed.
- Check the service speed in both directions.
- Secure the adjustment with the lock nut.

N.B. : Service speed is obtained only activating 12:S pilot valve

Adjustment of minimal pressure PV valve

The minimal pressure PV valve keeps a minimum amount of pressure in the hydraulic system, even when there is no load on the ram. This is achieved to avoid the ropes to get slack and come out of the pulley if the parachute devices on the car sling are activated or if the car lies on the shaft bottom springs. The PV valve is adjusted in the factory for a minimal pressure of about 10 bar.

If the hydraulic system is operated with a static pressure below the min. static pressure in operative conditions (i.e. during the assembly of the elevator), a tuning of the PV adjustment could be necessary to perform down travel.

Follow the procedure here below to modify the PV adjustment:

- Close the shut off valve and relief the static pressure with the manual lowering lever.
- Take away the sealing cap over the PV valve with a socket head wrench.
- Use a screwdriver to turn the adjustment grain: screw in for an higher min. pressure, screw out for a lower min. pressure.
- If the min. pressure is still too high, unscrew completely the adjustment grain and take away the spring below it.
- Put again the sealing cap in its original position, taking care that the rubber sealing is in contact with the valve body.
- Open the shut off valve and perform a trial car run.

Minimal pressure
PV valve

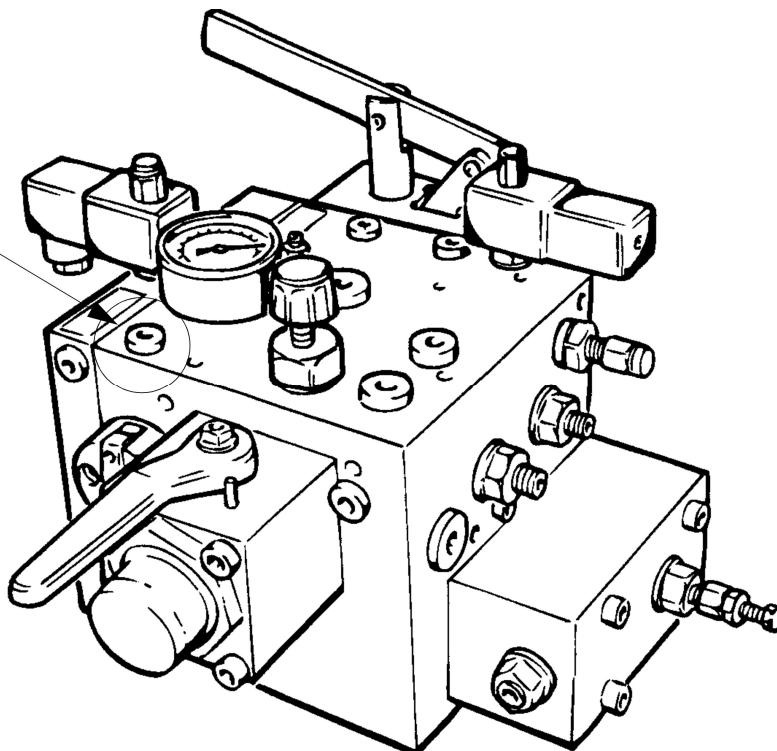

Valve details

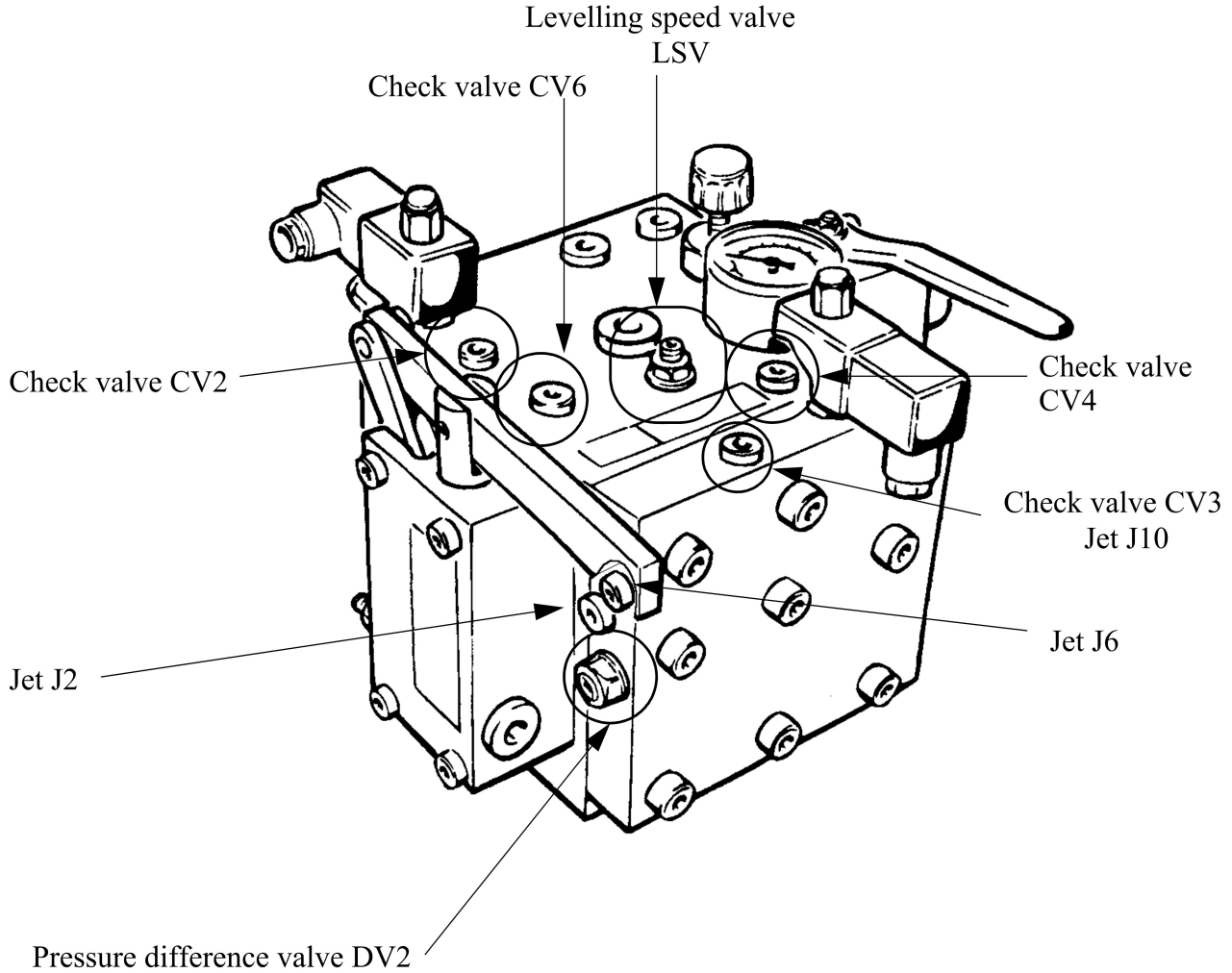

Jet J2	0,8 mm for all pump sizes. Placed under the plug
Jet J6	0,6 mm for all pump sizes. Placed under the plug
Jet J10	0,8 for all pump sizes. Placed under the plug
Check valve CV2	Placed under the plug
Check valve CV3	Placed under the Jet J10
Check valve CV4	Placed under the plug
Check valve CV6	Placed under the plug
Pressure difference valve DV2	Adjustment screw for elevator speed down
Levelling speed valve LSV	Adjustment screw for levelling speed

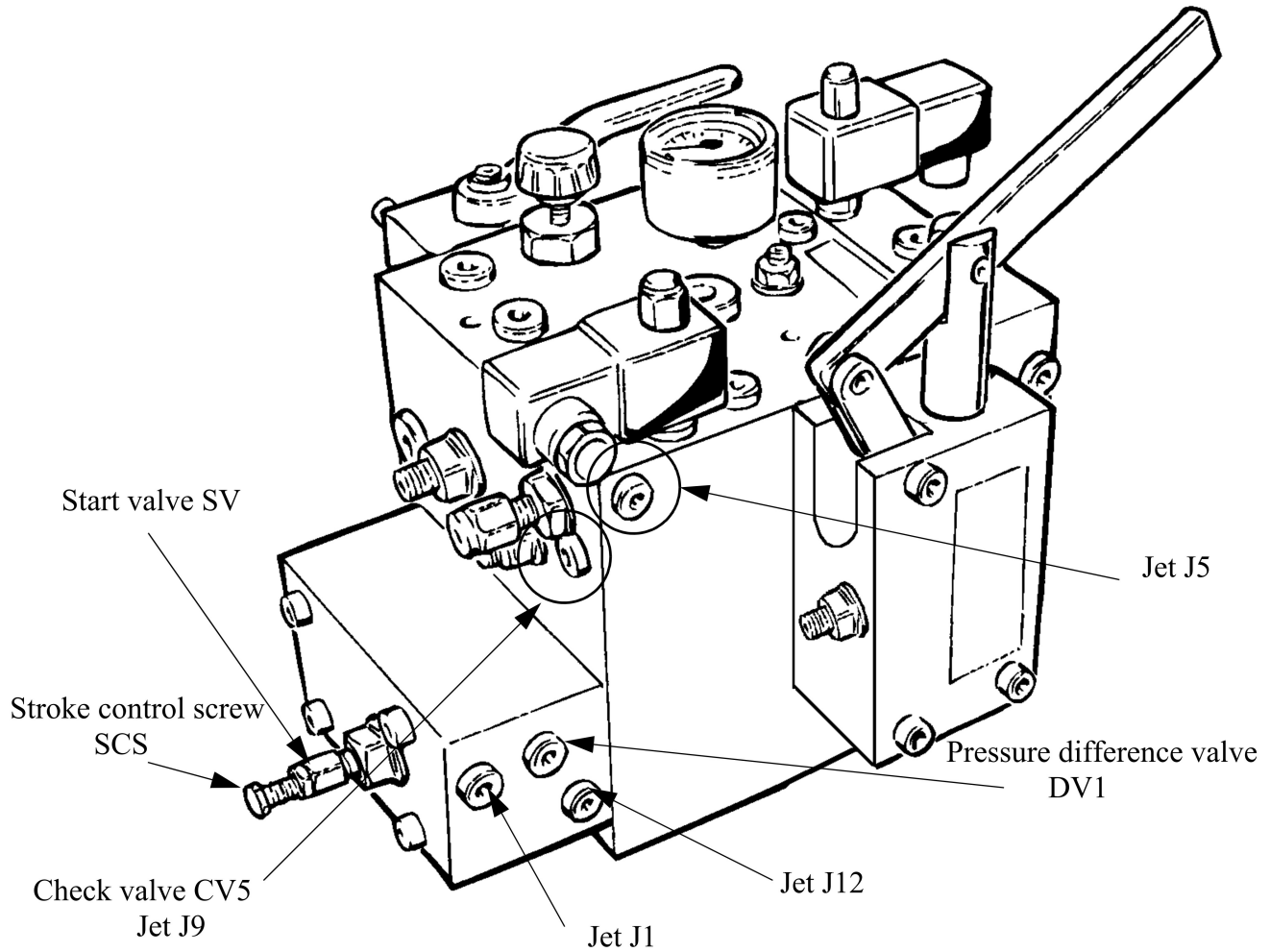

Jet J1	0,8 mm for pump size 70 a 145 l., 0,7 mm for larger pumps. Placed under the plug.
Jet J5	0,8 mm for all pump size. Placed under the plug. Only when reduction of acceleration downwards is required.
Jet J9	1,0 mm for all pump sizes. Placed under the plug
Jet J12	0,8 mm for all pump sizes. Placed under the plug
Check valve CV5	Placed under the Jet J9
Stroke control screw SCS	For adjusting of the by-pass pressure. preadjusted at the factory.
Start valve SV	Acceleration upwards is adjusted by means of the adjusting screw. Carried out the site.
Pressure difference valve DV1	Placed under the plug

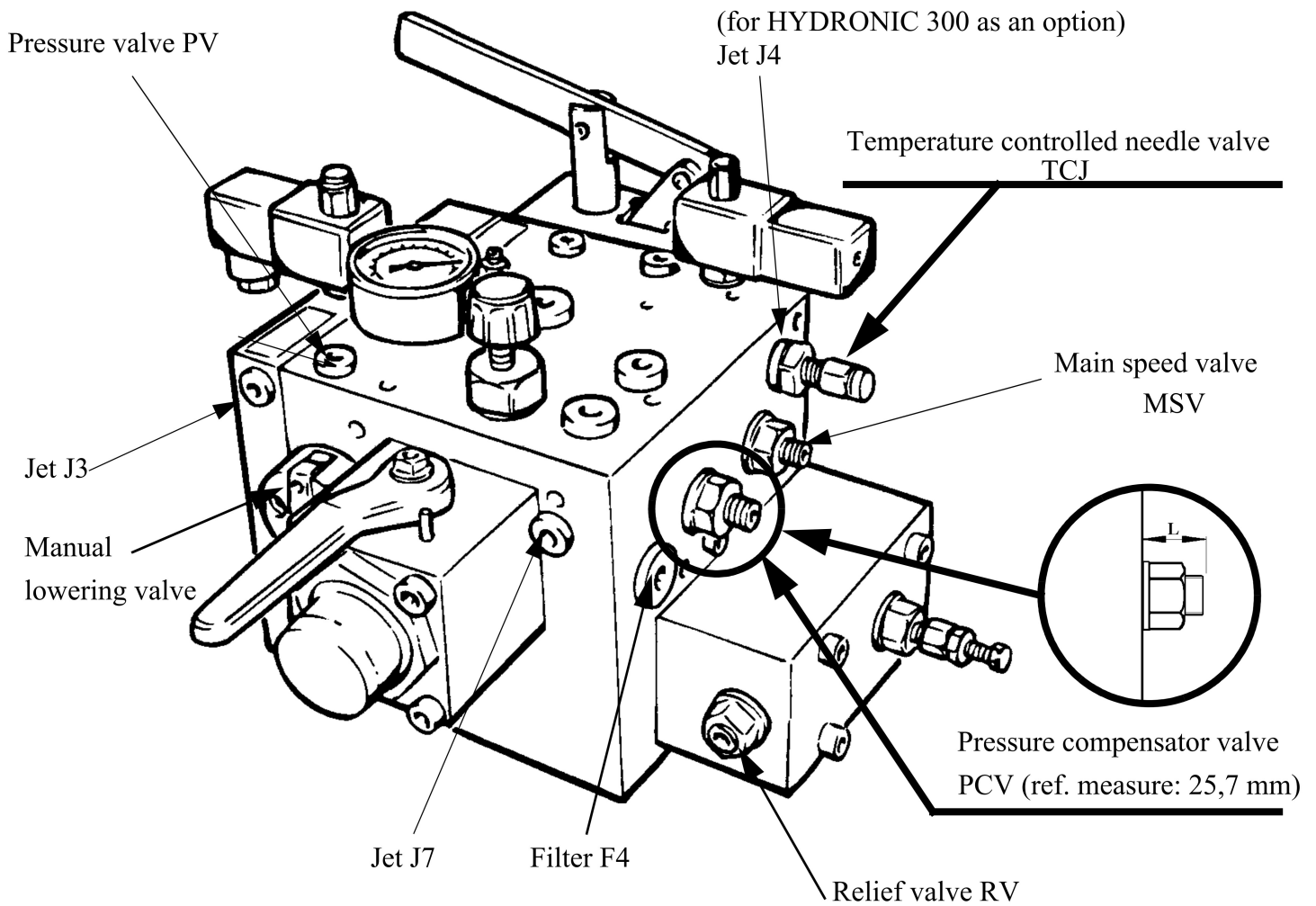

Jet J3	0,8 mm for all pump sizes. Placed under the plug.
Jet J4	1,0 mm for all pump size. Placed under TCJ. 0,8 mm for pump sizes up to 145 l/min, 0,7 for 172 up to 270 l/min without TCJ. Placed under the plug.
Jet J7	0,8 mm for all pump size. Placed under the plug.
Pressure valve PV	The valve spring has to be removed when unloaded cylinder is lowered. Placed under the plug.
Temperature controlled needle valve TCJ	Adjusting screw for acceleration down and deceleration up and down. To be adjusted at site.
Main speed valve MSV	The screw is adjusted to the correct value at the factory and should not required any adjustment at site.
Relief valve RV	The screw is adjusted to the correct pressure. at the factory and should not normally required any adjustment at site
Pressure compensator valve PCV	For testing the rupture valve. The screw is adjusted to the correct value at the factory and should not require any adjustment at site.

HYDRONIC 300

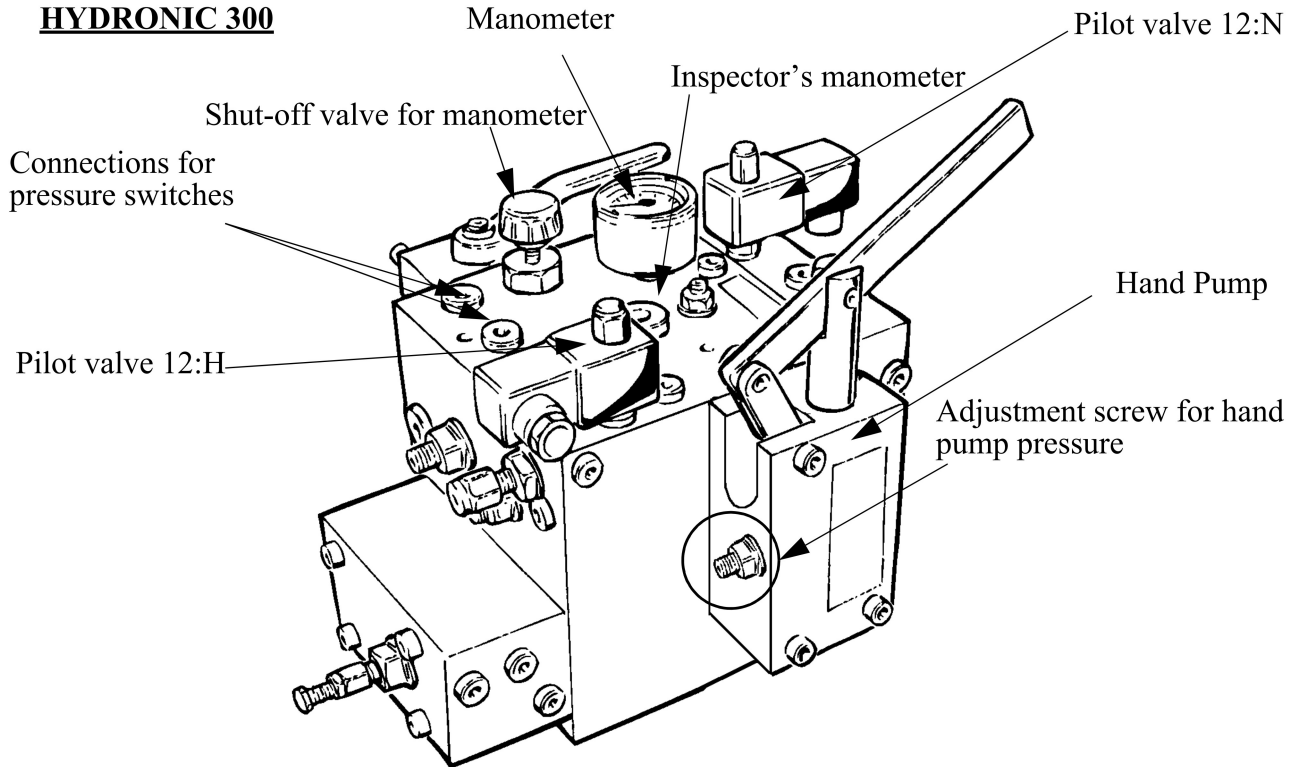

HYDRONIC 300 S

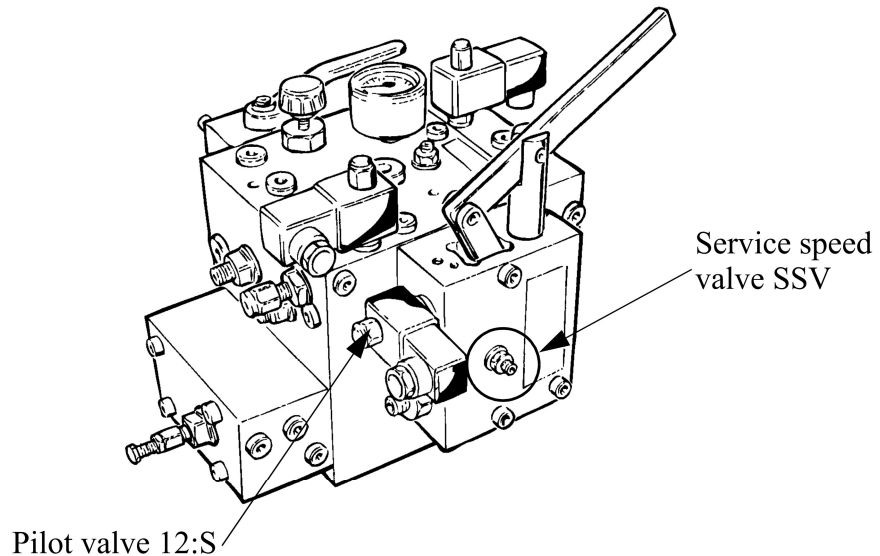

Pilot valve 12:H	Pilot valve for speed in up and down travel
Pilot valve 12:N	Pilot valve for down travel
Pilot valve 12:S	Pilot valve for service drive
Service speed valve SSV	Adjusting screw for service speed in up and down travel

MSV and PCV spool valves setup

The setup of these valves is done by the manufacturer during the power unit test; they don't require any further regulation. The following instructions are given only to check out and correct unwanted manipulations.

Spool valve PCV

The setup for this spool valve is the same for all the power unit: the reference measure is 25.7 mm from H300 body. **PCV vlv must be tuned only for the rupture valve operative test; after the test, adjust the valve to the original position.**

Spool valve MSV

This spool valve is regulated as follows:

Take away the locking nut and screw the regulation screw inward until it stops (it stands out from the H300 body for about 8 mm) then unscrew it out for the measure indicated in table 1. which is function of power unit oil flow.

The final dimension L is the sum of the (about) 8 mm, plus the measure indicated in table 1. Lock the screw with the locking nut: be careful not to rotate the screw while tightening the nut! Check again the dimension L after tightening the locking nut.

Table 1

Pump flow (L/min) 50 Hz (60 Hz)	Measure (mm)
50 (70)	7.5 (9)
70 (96)	9 (11)
96 (115)	11 (12)
115 (125)	12 (13)
125 (145)	13 (15)
145 (172)	15 (10,5)
172 (210)	10,5 (12)
210 (270)	12 (15)
270 (only 50 Hz for H300)	15 (-)

